

DEPARTMENT OF THE ARMY TECHNICAL MANUAL

DEPARTMENT OF THE AIR FORCE TECHNICAL ORDER

TM 11-855
TO 31R1-2URR-161

RADIO RECEIVER

R-389/URR

DEPARTMENTS OF THE ARMY AND THE AIR FORCE
AUGUST 1955

TM 11-855—TO 31R1-2URR-161 RADIO RECEIVER R-389/URR—1955

WARNING

DANGEROUS VOLTAGES EXIST IN THIS EQUIPMENT

Be careful when working on the
180-volt Power Supply PP-621 and
circuits connected to it, or on
the 115/230-volt a-c-line connections.

DON'T TAKE CHANCES!

Changes in force: C 3

CHANGE }
No. 3 }

HEADQUARTERS
DEPARTMENT OF THE ARMY
WASHINGTON, D. C., 17 December 1965

**RADIO RECEIVER R-389/URR, INCLUDING REPAIR PARTS
AND SPECIAL TOOL LISTS**

TM 11-855, 2 August 1955, is changed as follows:

The title of the manual is changed as shown above.

In figures 35, 36, and 89, delete the note (as added by C 1, 2 Feb 59) and substitute:

THE WIRES CONNECTED TO B+ 3/8A FUSE F102 HAVE BEEN REMOVED AND TIED TOGETHER, AND THE GROUND CONNECTION ON TRANSFORMER T801 HAS BEEN REMOVED. THERE IS NO CONNECTION BETWEEN DC 20A FUSE F103 AND P118-15 (NOT APPLICABLE TO FIGURE 36). TERMINAL 6 OF T801 IS CONNECTED THROUGH THE CONTACTS OF J818-15 AND P118-15 AND B+ 3/8A FUSE F102 TO GROUND. THE NAME OF B+ 3/8A FUSE HAS BEEN CHANGED TO HV 3/8A FUSE.

Page 2, paragraph 1 (as changed by C 2, 18 Sep. 63). Delete paragraph 1 and substitute:

1. Scope

This manual contains information for the installation and operation of Radio Receiver R-389/URR (fig. 1). It also includes the functioning, maintenance, and repair of the equipment.

Add paragraph 1.1 (as added by C 2, 18 Sep. 63) after paragraph 1.

1.1 Index of Publications

Refer to the latest issue of DA Pam 310-4 to determine whether there are new editions, changes, or additional publications pertaining to this equipment. DA Pam 310-4 is an index of current technical manuals, technical bulletins, supply manuals (types 7, 8, and 9), supply bulletins, lubrication orders, and modification work orders available through publications supply channels. The index lists the in-

dividual parts (-10, -20, -35P, etc.) and the latest changes to and revisions of each publication.

Delete paragraph 2 (as changed by C 2, 18 Sep. 63) and substitute:

2. Forms and Records

a. Reports of Maintenance and Unsatisfactory Equipment. Use equipment forms and records in accordance with instructions in TM 38-750.

b. Report of Damage or Improper Shipment. Fill out and forward DD Form 6 (Report of Damaged or Improper Shipment) as prescribed in AR 700-58 (Army), NAVSANDA Publication 378 (Navy), and AFR 71-4 (Air Force).

c. Reporting of Equipment Manual Improvements. The direct reporting of errors, omissions, and recommendations for improving this manual by the individual user is authorized and encouraged. DA Form 2028 (Recommended Changes to DA Publications) will be used for

*This manual supersedes C 1, 2 February 1959; C 2, 18 September 1963; TM 11-5820-360-10P, 25 January 1960 including C 1, 18 August 1960; TM 11-5820-360-20P, 25 January 1960; TM 11-5820-360-35P, 25 January 1960 including C 2, 22 January 1964; and REP 1282, August 1961.

reporting these improvements. This form will be completed using pencil, pen, or typewriter and forwarded direct to Commanding General, U. S. Army Electronics Command, ATTN: AMSEL-MR-(NMP)-MA, Fort Monmouth, N. J. 07703.

Page 5, paragraph 8d, line 9 from top of page. Delete all information after "R-389/URR" added by C 1, 2 February 1959.

Page 6, paragraph 10c (as added by C 1, 2 Feb. 59). Delete subparagraph c.

Paragraph 12.1 (as added by C 1, 2 Feb. 59). Delete paragraph 12.1 and substitute:

12.1 Changes in Equipment

All Radio Receivers R-389/URR have the B+ 3/8A fuse F102 in the ground lead of power transformer T801, and the name of this fuse has been changed to HV 3/8A. These changes on Power Supplies PP-621/URR used with R-389/URR restores interchangeability between all Power Supplies PP-621/URR and permit their being used in all Radio Receivers R-389/URR, R-390/URR, and R-391/URR.

Page 10, paragraph 15 (as added by C 1, 2 Feb. 59). Add subparagraph c after subparagraph b:

c. Reducing Surrounding Temperature of Receivers and Tubes.

- (1) When receivers are protected from dust by a cabinet, the dust covers should be removed to increase ventilation. Replace the screws and lockwashers that hold the dust covers in their positions so that they are available when the dust covers are reinstalled.
- (2) When receivers are used in fixed stations, remove all tube shields from the 6BJ6-type tubes located in the RF and IF amplifiers subchassis and from the rectifier-type 2515W tubes in the power supply subchassis.
- (3) Securely wrap the tube shields and dust covers. Mark the nomenclature and serial number of the receiver from which they were removed on the cover of the package. Store them for future use. Reinstall the tube shields and dust covers when the receivers are stored or shipped.

Page 20, chapter 4, heading (as changed by C 2, 18 Sep. 63). Change the heading to MAINTENANCE.

Delete sections I and II (as changed by C 2, 18 Sep. 63) and substitute:

Section I. OPERATOR'S PREVENTIVE MAINTENANCE

33. Scope of Operator's Preventive Maintenance

The maintenance duties assigned to the operator of Radio Receiver R-389/URR are listed below, together with references to the paragraphs covering the specific maintenance functions. The duties assigned do not require tools or test equipment other than those issued with the radio receiver.

- a. Daily preventive maintenance checks and services (paras 35 and 36).
- b. Cleaning (para 37).

34. Preventive Maintenance

Preventive maintenance is the systematic care, servicing, and inspection of equipment to prevent the occurrence of trouble, to reduce

downtime, and to assure that the equipment is serviceable.

a. *Systematic Care.* The procedures given in paragraphs 35 and 36 cover systematic care essential to proper upkeep and operation of the equipment.

b. *Preventive Maintenance Checks and Services.* The preventive maintenance checks and services chart (para 36) outlines functions to be performed at specific intervals. These checks and services are to maintain Army electronic equipment in a combat-serviceable condition; that is, in good general (physical) condition and in good operating condition. To assist operators in maintaining combat serviceability, the chart indicates what to check, how to check, and what the normal conditions are; the *references* column lists the paragraphs

or manuals that contain supplementary information. If the defect cannot be remedied by the operator, higher level of maintenance or repair is required. Records of these inspections must be in accordance with TM 38-750.

35. Preventive Maintenance Checks and Services Periods

a. Preventive maintenance checks and services on the R-389/URR are required daily.

b. Paragraph 36 specifies checks and services that must be accomplished daily and under the special following conditions for transportable installations:

- (1) When the equipment is initially installed.
- (2) When the equipment is reinstalled after removal for any reason.
- (3) At least once each week if the equipment is maintained in a *standby* condition.

36. Daily Preventive Maintenance Checks and Services Chart

Sequence No.	Item	Procedure	References
1	Exterior surfaces -----	Clean the exterior surfaces of the R-389/URR, including the meter and frequency indicator glasses.	Para 37.
2	Meter glass -----	Inspect the meter glass for cracks and breaks.	
3	Power cable assembly --	Inspect the power cable assembly for cuts, breaks, fraying, and deterioration. Examine the plugs for loose connections and for corroded or damaged contact surfaces.	
4	Knobs and switches ----	Check the mechanical action of each knob, switch, and dial for external and internal binding.	
5	Screws and nuts -----	Check all screws and nuts for tightness.	
6	Terminal boards -----	Check all terminal boards for tightness of connections.	
7	Fuses -----	Check to see that fuses and spares are in place.	
8	Operation -----	Check the receiver for normal operation -----	Paras 21 through 28.

37. Cleaning

Inspect the exterior of the receiver. The exterior should be free of dust, dirt, grease, and fungus.

Warning: Prolonged breathing of cleaning compound is dangerous; make certain that added ventilation is provided. Cleaning compound is flammable; do not use near a flame. Avoid contact with the skin; wash off any that spills on your hands.

a. Remove dirt and dust with a clean soft cloth. Dampen the cloth with cleaning compound (FSN 7930-395-9542) if necessary.

b. Remove grease, fungus, and ground-in dirt from the case; use a cloth dampened (not wet) with cleaning compound.

c. Remove dust and dirt from the frequency indicator glass and meter glass with a cloth dampened with cleaning compound.

Caution: Do not press hard on the glass; this could break it.

d. Remove dust and dirt from the plugs and jacks with a brush.

e. Clean the panel and control knobs; use a soft clean cloth. If necessary, dampen the cloth with water and use mild soap.

Section II. ORGANIZATIONAL PREVENTIVE MAINTENANCE

38. Scope of Organizational Preventive Maintenance

a. Paragraphs 38.1 through 38.4 contain instructions covering organizational maintenance of Radio Receiver R-389/URR. It includes instructions for performing preventive and periodic maintenance services and repair functions to be accomplished by the organizational repairman.

b. Organizational maintenance on the R-389/URR includes—

- (1) Replacement of defective fuses.
- (2) Preventive maintenance (paras 38.2, 38.3, and 38.4).
- (3) Troubleshooting (para 46).

38.1 Tools, Materials, and Test Equipment Required

The tools (including tools supplied with the receiver), materials, and test equipment required for organizational maintenance are as follows:

a. *Tools.* Tool Kit, Radio Repair TK-115/G.

b. *Special Tools* (fig. 7). The special tools, mounted on the back of the receiver, are as follows:

- (1) Tube pullers (2).
- (2) Right-angle Phillips screwdriver.
- (3) Fluted socket wrench.
- (4) Tube-pin straighteners (2).

c. *Materials.*

- (1) Cleaning compound.
- (2) Lint-free cheesecloth (part of TK-115/G).

(3) Sandpaper, No. 000 (part of TK-115/G).

d. *Test Equipment.*

- (1) Test Set, Electron Tube TV-7/U.
- (2) Multimeter TS-352/U.

38.2 Preventive Maintenance

a. Preventive maintenance is the responsibility of all levels concerned with the equipment and includes the inspection, testing, and repair or replacement of parts, subassemblies, or units that inspection and tests indicate would probably fail before the next scheduled periodic service. Preventive maintenance checks and services on Radio Receiver R-389/URR at the organizational level are made at quarterly intervals unless otherwise directed by the commanding officer.

b. Maintenance forms and records to be used and maintained on this equipment are specified in TM 38-750.

38.3 Quarterly Maintenance

Quarterly preventive maintenance checks and services on the R-389/URR are required. Periodic daily checks and services (para 36) constitute part of the quarterly preventive maintenance checks and services and must be performed concurrently. All deficiencies or shortcomings will be recorded in accordance with the requirements of TM 38-750. Perform all the checks and services listed in the quarterly preventive maintenance checks and services chart (para 38.4) in the sequence listed.

38.4 Quarterly Preventive Maintenance Checks and Services Chart

Sequence No.	Item	Procedure	References
1	Completeness -----	Check to see that equipment is complete -----	Paras 7, 11, and 12.
2	Publications -----	Check to see that all publications are complete, serviceable, and current.	DA Pam 310-4
3	Modifications -----	Determine whether new applicable MWO's have been published. All urgent MWO's must be applied immediately; all normal MWO's must be scheduled.	TM 38-750 and DA Pam 310-4.

Sequence No.	Item	Procedure	References
4	Preservation -----	Check all surfaces for evidence of fungus. Remove rust and corrosion with No. 000 sandpaper; then paint bare spots.	TB SIG 364
5	Knobs, jacks, and switches.	Inspect knobs, jacks, switches, pilot lamps, and connectors for looseness.	Fig. 9
6	Pluckout items -----	Inspect seating of tubes, pilot lamps, fuses, and crystal.	
7	Antenna relay -----	Inspect the antenna relay for loose mountings, pitted or burned contacts, misalignment of contacts, and insufficient spring tension.	
8	Resistors -----	Inspect resistors for cracks, chipping, blistering, and discoloration.	Figs. 50, 51, and 57.
9	Capacitors -----	Inspect capacitors for corrosion, dirt, and loose contacts.	Figs. 50, 51, 56, 58, and 59.
10	Transformers -----	Inspect transformers and chokes for overheating ----	Figs. 55, 60, 62, and 64.

Page 22. Delete section III (as changed by C 2, 18 Sep. 63).

Page 23. Delete figure 10 (as changed by C 2, 18 Sep. 63).

Page 24. Delete figure 11 (as changed by C 2, 18 Sep. 63).

Page 25, section IV. Change Section IV to Section III.

Page 34, paragraph 53*b*, line 13 (as added by C 1, 2 Feb. 59).

Add the following after "bandwidth": In receivers with serial number 51 and upward, resistor R221 has been eliminated. Resistor R220 is connected across Z208, and terminal 2 is connected to terminal 1.

Figure 13. Add the following to the notes (as added by C 1, 2 Feb 59):

5. IN RECEIVERS WITH SERIAL NUMBER 51 AND UPWARD, THE VALUE OF R220 IS 47K.
6. IN RECEIVERS WITH SERIAL NUMBER 51 AND UPWARD, R221 IS NOT USED. R220 IS CONNECTED BETWEEN PINS 1 AND 3 OF Z208, AND PIN 2 OF Z208 IS CONNECTED TO PIN 1 OF Z208.

Page 39, paragraph 56*a* (as changed by C 1, 2 February 1959). Make the following changes:

Lines 11 and 12: Delete "and its parallel resistor, R226."

Line 14. Delete the entire sentence.

Page 42, figure 18. Add the following (as added by C 1, 2 Feb. 59) to the notes:

5. IN RECEIVERS WITH SERIAL NUMBER 25 AND UPWARD, R702 IS 68K.

Page 43, figure 19. Change the value (as changed by C 1, 2 Feb. 59) of resistor R291 to 39K.

Page 50, figure 23 (foldout) (as changed by C 1, 2 Feb. 59). Delete resistor R266.

Page 52, figure 28 (foldout) (as changed by C 1, 2 Feb. 59). Change the value of R554 to 470.

Page 61, paragraph 80*c* (as changed by C 1, 2 Feb. 59). Delete the second sentence and substitute: Negative voltage feedback is provided through resistor R606 to local of amplifier V602.

Page 62, paragraph 80*c* (as changed by C 1, 2 Feb. 59). Make the following changes:

Line 11. Change internal to output.

Line 17. Change R606 to R609.

Last sentence. Delete the last sentence and substitute: In receivers with serial number 100 and upward, resistor R609 is not used and the junction of R604 and R608 is grounded. Capacitor C612 is connected in parallel with R608. The feedback circuits now differ from the original circuit in that the positive voltage feedback is still being provided, through R606,

to the cathode of V602 and negative current feedback by resistor R604.

Figure 32. Add the following to the notes (as added by C 1, 2 Feb. 59):

3. IN RECEIVERS WITH SERIAL NUMBER 100 AND UPWARD, R609 IS NOT USED. THE JUNCTION OF R604 AND R608 IS GROUND-ED AND CAPACITOR C612 (8 UF) IS ADDED IN PARALLEL WITH R608.

Figure 36 (foldout) (as changed by C 1, 2 Feb. 59). Change the value of resistor R625 from 2,200 to 1,000; and resistor R626 from 3,300 to 2,700.

Page 122. Add paragraph 123.1 after paragraph 123 (as added by C 1, 2 Feb. 59).

123.1 Measuring Overall Gain

a. Receiver Adjustment.

- (1) Connect the receiver under test to an ac powerline and permit the receiver to warm up to operating temperature.
- (2) Set the receiver front panel controls as follows:
 - (a) BANDWIDTH to 8 KC.
 - (b) FUNCTION to MGC.
 - (c) RF GAIN to 10 (max).
 - (d) BFO to OFF.

b. Connection of Vacuum Tube Voltmeter.

- (1) Connect a vtvm such as Electronic Multimeter TS-505/U, or equivalent, between DIODE LOAD terminal 15 (on the rear terminal strip of the receiver) and ground (fig. 7). Do not disturb the jumper between terminals 15 and 16.
- (2) Set the FUNCTION switch of the meter for measuring -dc volts.
- (3) Set the RANGE switch to 10 volts.

c. Connection of Signal Generator. Connect a signal generator such as RF Signal Generator AN/URM-25 through a suitable dummy antenna consisting of a nonreactive 125-ohm resistor (minus the output impedance of the signal generator) in series with Adapter Connectors UC-971/U and UG-636/U to BALANCED 125 OHM ANTENNA jack J108 located on the back panel of the receiver (fig. 7).

- (1) Connect the signal generator power cord to an ac power source.

- (2) Turn the power switch to ON and permit the signal generator to reach operating temperature.
- (3) Turn the internal modulation control to OFF.
- (4) Turn the signal generator and the radio receiver to 250 kc (low-band counter).
- (5) Adjust the signal generator output attenuator until the vtvm reads -7.0 volts. The receiver gain is normal when the signal generator output meter indicates between 1 and 4 microvolts. If more than 4 microvolts is required, follow the procedure given in *d* below.

d. If the overall gain is below normal, test the tubes in the RF amplifier and replace the defective tubes. If, after testing and replacing all weak tubes in the RF amplifier, the overall gain is still below normal, check the adjustment of GAIN ADJ potentiometer R562 (para 124).

Page 122, paragraph 124 (as changed by C 1, 2 Feb. 59). Delete paragraph 124 and substitute:

124. Adjustment of GAIN ADJ Potentiometer R562

a. If a generator output of more than 4 microvolts is required to produce a reading of -7.0 volts when measuring the overall gain (para 123.1), the receiver gain is below normal. Proceed as follows to restore the receiver overall gain to normal.

- (1) Disconnect connectors P225 and P-226 from jacks J525 and J526, located on the IF subchassis (fig. 55).
- (2) Connect a suitable terminated signal generator lead between IF jack J525 and receiver ground (chassis). When using RF Signal Generator Set AN/URM-25, it must be terminated in Test Adapter MX-1487/URM-25D, or equivalent.
- (3) Connect a vtvm, such as Electronic Multimeter TS-505/U, between DIODE LOAD terminal 15, on the rear terminal strip of the receiver, and ground (fig. 7). Do not disturb the

- jumper between terminals 15 and 16. Set the FUNCTION switch of the meter for measuring -dc volts.
- (4) Connect the receiver under test to an ac source and allow it to warm up to operating temperature. Set the receiver controls as follows:
 - (a) BANDWIDTH to 8 KC.
 - (b) FUNCTION to MGC.
 - (c) RF GAIN to 10 (max).
 - (d) BFO to OFF.
 - (5) Turn the modulation control to OFF.
 - (6) Tune the signal generator to 455 kc. When the unmodulated 455 kc signal is injected into the IF amplifier, a hum in the audic output may indicate a faulty type 6BJ6 tube in the third, fourth, or fifth IF amplifier stages (V503, V504, or V505). This can be checked by substituting another tube of the same type, because these defects often are not detected in a standard tube tester.
 - (7) Adjust the signal generator for an output of 150 microvolts.

Note. It may not always be possible to produce -7.0 volts at the diode load terminal with an input to IF subchassis jack J525 of 150 microvolts. In this case, the IF gain should be set so that the input to the IF is not less than 100 microvolts or greater than 200 microvolts to produce the -7.0 volts at diode load terminal 14.

- (8) Adjust GAIN ADJ potentiometer R-562 (fig. 55) for a reading of -7.0 volts on the vtvm.

b. If the -7.0-volt reading cannot be obtained after the maximum adjustment of GAIN ADJ potentiometer R562, remove and test the IF amplifier tubes in a mutual conductance tube tester such as Test Set, Electron Tube TV-7/U, or equivalent. Replace the defective tubes. Record the mutual conductance of all the tubes tested, replace them in their original sockets, and readjust GAIN ADJ potentiometer R562 until the vtvm indicates -7.0 volts. If the -7.0-volt reading cannot be obtained after replacing burned out and/or shorted tubes with good tubes, replace the weakest tubes in the IF amplifier, one at a time, and again readjust GAIN ADJ potentiometer R562, after each tube replacement, until a reading of -7.0 volts is obtained.

c. Remove the signal generator from jack J525 and reconnect plugs P225 and P226 to jacks J525 and J526. Disconnect the vtvm.

d. Check the overall gain of the receiver in accordance with paragraph 123.1.

e. If the overall gain is still below normal, check the receiver alignment in accordance with the instructions given in paragraphs 121, 122, and 123.

Page 124, section IV, heading. Change the heading to: DEPOT INSPECTION STANDARD.

Paragraph 130. Delete subparagraph c and substitute:

c. RF Signal Generator AN/URM-25F.

Page 128, appendix (as added by C 2, 18 Sep. 63). Delete the appendix and substitute:

APPENDIX I

REFERENCES

Following is a list of applicable references available to the organizational repairman of Radio Receiver R-389/URR:

DA Pam 310-4	Index of Technical Manuals, Technical Bulletins, Supply Manuals (Types 7, 8, and 9), Supply Bulletins, Lubrication Orders, and Modification Work Orders
--------------	---

TM 11-855
C3

TB SIG 364 Field Instructions for Painting and Preserving Electronics Command
 Equipment

TM 11-5820-359-12P Operator and Organizational Maintenance Repair Parts and Special Tool
 Lists and Maintenance Allocation Chart: Power Supply PP-621/URR

TM 11-5820-359-35P Field and Depot Maintenance Repair Parts and Special Tool Lists: Power
 Supply PP-621/URR

TM 38-750 Army Equipment Record Procedures
 Add appendixes II, III, and IV after appendix I.

APPENDIX II

BASIC ISSUE ITEMS

Section I. INTRODUCTION

1. General

This appendix lists items supplied for initial operation and for running spares. The list includes tools, parts, and material issued as part of the major end item. The list includes all items authorized for basic operator maintenance of the equipment. End items of equipment are issued on the basis of allowances prescribed in equipment authorization tables and other documents that are a basis for requisitioning. This equipment is combat essential.

2. Columns

Columns are as follows:

a. Federal Stock Number. This column lists the 11-digit Federal stock number.

b. Designation by Model. Not used.

c. Description. Nomenclature or the standard item name and brief identifying data for each item are listed in this column. When requisitioning, enter the nomenclature and description.

d. Unit of Issue. The unit of issue is each unless otherwise indicated and is the supply term by which the individual item is counted for procurement, storage, requisitioning, allowances, and issue purposes.

e. Expendability. Nonexpendable items are indicated by NX. Example items are not annotated.

f. Quantity Authorized. Under "Items Comprising an Operable Equipment," the column lists the quantity of items supplied for the initial operation of the equipment. Under "Running Spare Items" the quantities listed are those issued initially with the equipment as spare parts. The quantities are authorized to be kept on hand by the operator for maintenance of the equipment.

g. Illustration. The "Item No." column lists the reference designations that appear on the part in the equipment. These same designations are also used on any illustrations of the equipment. The numbers in the "Figure No." column refer to the illustrations where the part is shown.

SECTION II: FUNCTIONAL PARTS LIST

FEDERAL STOCK NUMBER	DESIGNATION BY MODEL	DESCRIPTION	UNIT OF ISSUE	EXP	QTY AUTH	ILLUSTRATION	
						FIGURE NO	ITEM NO
		RECEIVER, RADIO R-389/URR					
5920-503-1417		RECEIVER, RADIO R-389/URR:			NX	1	
		ITEMS COMPRISING AN OPERABLE EQUIPMENT					
ORD THRU AGC		TECHNICAL MANUAL TM11-855				2	
5925-173-8839		CABLE ASSEMBLY, POWER, ELECTRICAL CX-1358/U:				1	1
5995-284-7110		CABLE ASSEMBLY, RADIOFREQUENCY: Collins part/dwg 5068142002				1	
5925-293-8770		CABLE ASSEMBLY, RADIOFREQUENCY: Collins part/dwg 5068140002				2	
5955-537-4027		CRYSTAL UNIT, QUARTZ CR-18/U: 10,455 kc; MIL spec-MIL-C-3098			NX	1	49 Y201
5955-290-0568		CRYSTAL UNIT, QUARTZ CR-45/U: MIL spec MIL-C-3098			NX	1	23 Y501
5920-539-9000		POWER SUPPLY PP-621/URR			NX	1	62
		RUNNING SPARE ITEMS					
		RECEIVER, RADIO R-389/URR					
5960-188-3551		ELECTRON TUBE: MIL type 6AK6				1	55 60 60 V206 V603 V604
5960-264-3002		ELECTRON TUBE: MIL type 5750/6BE6W				1	49 49 49 V205 V212 V213
5960-188-3604		ELECTRON TUBE: MIL type 6B116 (Item Nos: V206 thru V209, V211, V607, V702)				3	49 60 See desc column
5960-188-6589		ELECTRON TUBE: MIL type 6BJ6 (Item Nos: V202, V203, V501 thru V505, V509)				3	49 55 See desc column
5960-235-8215		ELECTRON TUBE: MIL type 6C4W				1	49 V210
5960-262-0167		ELECTRON TUBE: MIL type 12AT7WA				1	49 60 V204 V602
5960-262-0210		ELECTRON TUBE: MIL type 5814A (Item Nos: V507, V510, V511, V601)				2	See desc column
5960-287-0286		ELECTRON TUBE: MIL type 5651WA				1	60 60 V608 V609

APPENDIX III

MAINTENANCE ALLOCATION

Section I. INTRODUCTION

I. General

a. This appendix assigns maintenance functions to be performed on components, assemblies, and subassemblies by the lowest appropriate maintenance category.

b. Columns in the maintenance allocation chart are as follows:

- (1) *Part or component.* This column shows only the nomenclature or standard item name. Additional descriptive data are included only where clarification is necessary to identify the component. Components, assemblies, and subassemblies are listed in top-down order. That is, the assemblies which are part of a component are listed immediately below that component, and subassemblies which are part of an assembly are listed immediately below that assembly. Each generation breakdown (components, assemblies, or subassemblies) is listed in disassembly order or alphabetical order.
- (2) *Maintenance function.* This column indicates the various maintenance functions allocated to the categories.
 - (a) *Service.* To clean, to preserve, and to replenish lubricants.
 - (b) *Adjust.* To regulate periodically to prevent malfunction.
 - (c) *Inspect.* To verify serviceability and detect incipient electrical or mechanical failure by scrutiny.
 - (d) *Test.* To verify serviceability and to detect incipient electrical or mechanical failure by use of special

equipment such as gages, meters, etc.

- (e) *Replace.* To substitute serviceable components, assemblies, or subassemblies, for unserviceable components, assemblies, or subassemblies.
- (f) *Repair.* To restore an item to serviceable condition through correction of a specific failure or unserviceable condition. This function includes but is not limited to welding, grinding, riveting, straightening, and replacement of parts other than the trial and error replacement of running spare type items such as fuses, lamps, or electron tubes.
- (g) *Align.* To adjust two or more components of an electrical system so that their functions are properly synchronized.
- (h) *Calibrate.* To determine, check, or rectify the graduation of an instrument, weapon, or weapons system, or components of a weapons system.
- (i) *Overhaul.* To restore an item to *completely serviceable* condition as prescribed by serviceability standards. This is accomplished through employment of the technique of "Inspect and Repair Only as Necessary" (IROAN). Maximum utilization of diagnostic and test equipment is combined with minimum disassembly of the item during the overhaul process.

- (j) *Rebuild.* To restore an item to a standard as near as possible to original or new condition in appearance, performance, and life expectancy. This is accomplished through the maintenance technique of complete disassembly of the item, inspection of all parts or components, repair or replacement of worn or unserviceable elements to original manufacturing standards and/or specifications and subsequent reassembly of the item.
- (3) *Operator, organization, direct support, and depot.* The symbol X indicates the categories responsible for performing that particular maintenance operation, but does not necessarily indicate that repair parts will be stocked at that level. Categories higher than those marked by X are authorized to perform the indicated operation.
- (4) *Tools required.* This column indicates codes assigned to each individual tool, equipment, test equipment, and maintenance equipment referenced. The grouping of codes in each column of the maintenance allocation chart in-

dicates the tool, test, and maintenance equipment required to perform the maintenance function.

- (c) *Remarks.* Entries in this column will be utilized when necessary to clarify any of the data cited in the preceding columns.
- c. Columns in the allocation of tools for maintenance functions are as follows:
- (1) *Tools required for maintenance functions.* This column lists tools, test, and maintenance equipment required to perform the maintenance functions.
 - (2) *Operator, organization, direct support, and depot.* The dagger (†) indicates the categories normally allocated the facility.
 - (3) *Tool code.* This column lists the tool code assigned.

2. Maintenance by Using Organizations

When this equipment is used by Signal services organizations organic to theater headquarters or communication zones to provide theater communications, those maintenance functions allocated up to and including general support are authorized to the organization operating this equipment.

SECTION II. MAINTENANCE ALLOCATION CHART

PART OR COMPONENT	MAINTENANCE FUNCTION	Echelons				TOOLS REQUIRED	REMARKS
		O	C	Ds	D		
RECEIVER, RADIO R-389/URR	service	X					Controls Interior Exterior Final Test Item No. 8 used at 5th echelon only
	adjust	X					
	inspect	X					
	test	X				10 5,9 1 thru 9 12, 13	
	replace	X				10 11	
	repair		X			2,3,4,7	
	align		X			2,3,4,7	
	calibrate		X			11	
	rebuild			X			
	replace		X				
AMPLIFIER, ASSEMBLY	repair		X				
	rebuild		X				
AMPLIFIER, AUDIO FREQUENCY	replace		X				
BRUSH, ELECTRICAL CONTACT	repair		X				
	rebuild		X				
CABLE, RADIOFREQUENCY	replace		X				
CABLE, POWER, ELECTRICAL	replace		X				
CAPACITOR	replace		X				
COIL, RADIOFREQUENCY	replace		X				
COMMUTATOR AND CONNECTOR ASSEMBLY	replace		X				
CONNECTOR, PLUG, ELECTRICAL	replace		X				
CONNECTOR, RECEPTACLE, ELECTRICAL	replace		X				
CORE, ADJUSTABLE TUNING	replace		X				
COUNTER MECHANICAL	replace		X				
CRYSTAL UNIT QUARTZ	replace		X				
	repair		X				
DETECT, SWITCH	rebuild			X			
ELECTRON TUBE	replace		X				
FILTER, BAND PASS	replace		X				
FILTER, LOW PASS	replace		X				
FUSE, CARTRIDGE	replace	X					

PART OR COMPONENT	MAINTENANCE FUNCTION	ECHOLON				TOOLS REQUIRED	REMARKS
		O/C	O	DS	GS		
RECEIVER, RADIO R-389/URR (continued)							
FUSEHOLDER	replace			X			
GEAR ASSEMBLY	replace			X			
GEAR	replace			X			
INSERT, ELECTRICAL CONNECTOR	replace			X			
JACK	replace			X			
KNOB	replace		X				
LAMP	replace	X					
LAMPHOLDER	replace			X			
LEADSCREW ASSEMBLY	replace			X			
METER, AUDIO LEVEL	replace			X			
	repair			X			
	rebuild				X		
MOTOR	replace			X			
	repair			X			
	rebuild				X		
OSCILLATOR, RADIOFREQUENCY	replace			X			
	repair			X			
	rebuild				X		
OVEN, TUNED CIRCUIT	replace			X			
POWER SUPPLY PP-621/URR	replace			X			
	service	X					
	repair			X			See TML-5820-359-12P for maintenance allocation
	rebuild				X		
POWER SUPPLY	replace			X			
	repair			X			
	rebuild				X		
REACTOR	replace			X			
RECEIVER SUBASSEMBLY	replace			X			
	repair			X			
	rebuild				X		
RECTIFIER, METALLIC	replace			X			
RELAY, ARMATURE	replace			X			
RESISTOR, CURRENT REGULATING	replace	X					

PART OR COMPONENT	MAINTENANCE FUNCTION	ECHELON				TOOLS REQUIRED	REMARKS
		O/C	O	DS	D		
RECEIVER, RADIO R-389/URR (continued)							
RESISTOR	replace			X			
ROLLER, CLATCH	replace			X			
SHIELD, ELECTRON TUBE	replace		X				
SOCKET	replace			X			
SPRING, HELICAL, EXTENSION	replace			X			
SUPPRESSOR, PARASITIC	replace			X			
SWITCH	replace			X			
TRANSFORMER	replace			X			
TUNER, RADIOFREQUENCY	replace			X			

PART OR COMPONENT	MAINTENANCE FUNCTION	ECHELON				TOOLS REQUIRED	REMARKS
		O/C	O	DS	GS		
RECEIVER, RADIO R-389/URR (continued)							
FUSEHOLDER	replace			X			
GEAR ASSEMBLY	replace			X			
GEAR	replace			X			
INSERT, ELECTRICAL CONNECTOR	replace			X			
JACK	replace			X			
KNOB	replace		X				
LAMP	replace	X					
LAMPHOLDER	replace			X			
LEADSCREW ASSEMBLY	replace			X			
METER, AUDIO LEVEL	replace			X			
	repair			X			
	rebuild			X			
MOTOR	replace			X			
	repair			X			
	rebuild			X			
OSCILLATOR, RADIOFREQUENCY	replace			X			
	repair			X			
	rebuild			X			
OVEN, TUNED CIRCUIT	replace			X			
POWER SUPPLY PP-621/URR	replace		X				
	service						
	repair						See TML-5820-359-12P for maintenance allocation
	rebuild						
POWER SUPPLY	replace			X			
	repair			X			
	rebuild			X			
REACTOR	replace			X			
RECEIVER SUBASSEMBLY	replace			X			
	repair			X			
	rebuild			X			
RECTIFIER, METALLIC	replace			X			
RELAY, ARMATURE	replace			X			
RESISTOR, CURRENT REGULATING	replace	X					

PART OR COMPONENT	MAINTENANCE FUNCTION	ECHELON					TOOLS REQUIRED	REMARKS
		O/C	O	DS	GS	D		
RECEIVER, RADIO R-389/URR (continued)								
RESISTOR	replace			X				
ROLLER, CLUTCH	replace			X				
SHIELD, ELECTRON TUBE	replace		X					
SOCKET	replace			X				
SPRING, HELICAL, EXTENSION	replace			X				
SUPPRESSOR, PARASITIC	replace			X				
SWITCH	replace			X				
TRANSFORMER	replace			X				
TUNER, RADIOFREQUENCY	replace			X				

SECTION III. ALLOCATION OF TOOLS FOR MAINTENANCE FUNCTIONS

TOOLS REQUIRED FOR MAINTENANCE FUNCTIONS	MAINTENANCE CATEGORY				TOOL CODE	REMARKS
	O/C	O	DS	D		
RECEIVER, RADIO R-389/URR (continued)					1	
ANALYZER, SPECTRUM TS-723/U					2	
AUDIO OSCILLATOR TS-382A/U					3	
ELECTRONIC MULTIMETER TS-505/U					4	
FREQUENCY COUNTER AN/USM-26					5	
MULTIMETER AN/URM-105					6	
OUTPUT METER TS-585/U					7	
R. F. SIGNAL GENERATOR AN/URM-25					8	
TEST SET ELECTRON TUBE TV-2/U					9	
TEST SET ELECTRON TUBE TV-7/U					10	
TOOL EQUIPMENT TE-41					11	
TOOL EQUIPMENT TE-113					12	
TRANSFORMER, VARIABLE POWER CN-16A/U					13	
VOLTMETER, METER ME-30A/U						

APPENDIX IV

ORGANIZATIONAL, DIRECT AND GENERAL SUPPORT, AND DEPOT REPAIR PARTS AND SPECIAL TOOL LISTS

Section I INTRODUCTION

1. General

a. This manual includes an organizational, direct and general support, and depot maintenance special tool lists. This equipment is combat essential.

(1) The organizational maintenance repair parts and special tools list shows the repair parts authorized for organizational maintenance and is a basis for requisitioning by organizations which are authorized the major item of equipment. End items of equipments are issued on the basis of allowances prescribed in equipment authorization tables and other documents that are a basis for requisitioning.

(2) The direct and general support and depot maintenance repair parts and special tools list shows the quantities of repair parts authorized for direct and general support maintenance and is a basis for requisitioning authorized parts. It is also a guide for depot maintenance in establishing initial levels of spare parts.

b. Columns are as follows:

(1) *Source, maintenance, and recoverability code.* Source, maintenance, and recoverability codes indicate the supply service responsible for supply, the maintenance category at which an item is stocked, categories at which an item is installed or repaired, and whether an item is repairable or salvageable. The source code column is divided into four parts—

(a) *Column A.* This column indicates the material code and designates the area of responsibility for supply. AR 310-1 defines the basic numbers used to identify the material code. If the part is Signal material responsibility, the column is left blank.

(b) *Column B.* Not used.

(c) *Column C.* This column indicates the lowest maintenance category authorized to install the part.

O—Organizational maintenance (operator and organizational).
F—Direct support maintenance.

(d) *Column D.* The symbol in this column indicates whether the item is repairable or salvageable, as follows:

R—indicates that the part or assembly is economically repairable and is supplied, when available, on an exchange basis.

(2) *Federal stock number.* This column lists the 11-digit Federal stock number.

(3) *Designation by model.* Not used.

(4) *Description.* Nomenclature or the standard item name and brief identifying data for each item are listed in this column. When requisitioning, enter the nomenclature and description.

(5) *Unit of issue.* The unit of issue is each unless otherwise indicated and is the supply term by which the individual item is counted for procure-

ment, storage, requisitioning, allowances, and issue purposes.

- (6) *Expendability.* Nonexpendable items are indicated by NX. Expendable items are not annotated.
- (7) *Quantity incorporated in unit.* This column lists the quantity of each part found in a given assembly, component, or equipment.
- (8) *Organizational.* An asterisk indicates that an item is not authorized for stockage but if required, may be requisitioned for immediate use only.
- (9) *Direct support.* This column indicates quantities of repair parts authorized for initial stockage for use in direct support maintenance and in supply support to organization. The quantities are based on 100 equipments to be maintained for a 15-day period.
- (10) *General support.* The numbers in this column indicate quantities of repair parts authorized for initial stockage for use in general support maintenance. The quantities are based on 100 equipments to be maintained for a 15-day period.
- (11) *Depot.* The numbers in this column indicate quantities of repair parts authorized for depot maintenance and for initial stockage for maintenance, and for supply support to lower categories. The entries are based on the quantity required for rebuild of 100 equipments.
- (12) *Illustration.* The "Item No." column lists the reference designations that appear on the part in the equipment. These same designations are also used on any illustrations of the equipment. The numbers in the "Figure No." column refer to the illustrations where the part is shown.

2. Parts for Maintenance

When this equipment is used by Signal service organizations organic to theater headquarters or communication zones to provide theater communications, those repair parts authorized up to and including general support

are authorized for stockage by the organization operating this equipment.

3. Electron Tubes

The consumption rates given for tubes are conservative theoretical estimates and are provided for use only when more complete information, such as data based on operating experience, is not available. These figures are based on levels and requirements for equipment actually in use, not on authorizations or equipment stored in depots.

4. Requisitioning Information

a. The allowance factors are based on 100 equipments. In order to determine the number of parts authorized for initial stockage for the specific number of equipments supported, the following formula will be used and carried out to two decimal places.

Specific number of equipments supported

$$X \frac{\text{allowance factor}}{100} =$$

Number of parts authorized for initial stockage.

b. Fractional values obtained from above computation will be rounded to whole numbers as follows:

- (1) When the total number of parts authorized is less than 0.5, the quantity authorized will be zero.
- (2) When the total number of parts authorized is between 0.5 and 1.0, the quantity authorized will be one.
- (3) For all values above one, fractional values below 0.5 will revert to the next lower whole number and fractional value 0.5 and above will advance to the next higher whole number.
- (4) Parentheses around the allowance factor listed in the direct support column indicate that the item is combat essential and that a minimum quantity of one is authorized for initial stockage even though the computed quantity is less than 0.5.

c. The quantities determined in accordance with the above computation represent the initial stockage for a 15-day period.

SECTION II. ORGANIZATIONAL FUNCTIONAL PARTS LIST

FEDERAL STOCK NUMBER	DESIGNATION BY MODEL	DESCRIPTION	UNIT OF ISSUE	EXP	QTY IN UNIT	MAINT ORG ALLOW.	ILLUSTRATION	
							FIGURE NO.	ITEM NO.
		RECEIVER, RADIO R-389/URR						
5820-503-1417		RECEIVER, RADIO R-389/URR:		NX				
5955-537-4027		CRYSTAL UNIT, QUARTZ CR-18/U: 10,455 kc; MIL spec MIL-C-3098		NX	1	*	49	Y201
5955-250-0568		CRYSTAL UNIT, QUARTZ CR-45/U: MIL spec MIL-C-3098		NX	1	*	23	Y501
5960-188-3551		ELECTRON TUBE: MIL type 6AK6			3	*	55 60 60	V506 V603 V604
5960-264-3002		ELECTRON TUBE: MIL type 5750/6BE6W			3	*	49 49 49	V205 V212 V213
5960-188-3602		ELECTRON TUBE: MIL type 6BH6 (Item Nos: V206 thru V209, V211, V607, V702)			7	*	49 60	See desc column
5960-188-6589		ELECTRON TUBE: MIL type 6BJ6 (Item Nos: V202, V203, V501 thru V505, V509)			8	*	49 55	See desc column
5960-235-8215		ELECTRON TUBE: MIL type 6C4W			2	*	49	V210
5960-262-0167		ELECTRON TUBE: MIL type 12AT7WA			2	*	49 60	V204 V602
5960-262-0210		ELECTRON TUBE: MIL type 5814A (Item Nos: V507, V510, V511, V601)			4	*	55 60	See desc column
5960-262-0286		ELECTRON TUBE: MIL type 5651WA			2	*	60 60	V608 V609
5960-264-2089		ELECTRON TUBE: MIL type 5749/6BA6W			2	*	55 67	V508 V701
5960-264-1486		ELECTRON TUBE: 6082 Buships spec			2	*	60 60	V605 V606
5920-280-8628		FUSE, CARTRIDGE: 3/8 amp; 250v; renewable; Buss Mfg Co type AGC3-8			1	*	7	F102
5920-131-9821		FUSE, CARTRIDGE: 3 amp; 125v; renewable; Littelfuse p/n 313003			1	*	7	F101
5920-131-9915		FUSE, CARTRIDGE: 20 amp; 32v; MIL-F-15160 type FO4A20ROA			1	*	7	F103
5355-607-9084		KNOB: Rd; blk; 2-3/4 in dia by 1-1/4 in thk; Collins part/dwg 5068130002			1	*		
5355-607-9338		KNOB: bar; blk; 3/4 in lg x 15/16 in dia; Collins part/dwg 281 009 300			8	*		
5355-665-1307		KNOB: bar; blk; 7/8 in lg x 1-1/8 in dia; Sig dwg SC-C-176385			7	*		

SECTION III. DIRECT AND GENERAL SUPPORT AND DEPOT FUNCTIONAL PARTS LIST

SOURCE CODE	FEDERAL STOCK NUMBER	DESIGNATION BY MODEL	DESCRIPTION	UNIT OF ISSUE	EXP	QTY IN UNIT	DIRECT SUPPORT	GENERAL SUPPORT	DEPOT	ILLUSTRATION	
										FIGURE NO.	ITEM NO.
A			RECEIVER, RADIO R-389/URR								
B			RECEIVER, RADIO R-389/URR:								
C	5820-503-1417		AMPLIFIER, ASSEMBLY: 180 vac, 60 cyc 15 w; Collins part/dwg 505 9196 005	NX		1	0.2	0.1	4		
D	5815-395-8821		AMPLIFIER, AUDIO FREQUENCY: 500 mv and 10 mv output 180 vdc, 65 ma 26 v, 1.4 amp, 18.6 v, 150 ma; Collins part/dwg 505 9533 004	NX		1	0.2	0.1	4		
	5815-219-6118		BRUSH, ELECTRICAL CONTACT: for band switching motor; Collins part/dwg 234 019000			2	0.4	0.2	10		
	5977-284-6565		BRUSH, ELECTRICAL CONTACT: for tuning motor; S1E dwg SC-D-99877-118			1	0.2	0.1	6		
	5977-284-9977		CABLE, RADIOFREQUENCY: coax; 75 ohm impedance			36	0.2	0.1	204		
	6145-284-0621		NOTE: Authorized quantities will be a minimum or a multiple of 36 ft								
	6145-548-1258		CABLE, POWER ELECTRICAL: MIL type C6-02MGF(2/18)0300			8	0.2	0.1	6		
	5910-556-9427		NOTE: Authorized quantities will be a minimum or a multiple of 8 ft								
	5910-197-1485		CAPACITOR, FIXED, CERAMIC DIELECTRIC: 5 mmf ± 0.25 mmf; 500v dcv; MIL type CC20CH050C			2	0.4	0.2	10		C215 C533
	5910-666-7656		CAPACITOR, FIXED, CERAMIC DIELECTRIC: 12 mmf ± 5%; MIL type CC20CH12CJ			1	0.2	0.1	6		C536
			CAPACITOR, FIXED, CERAMIC DIELECTRIC: 91 mmf ± 2%; 500 vdcw; Collins part/dwg 928 4918 00			1	0.2	0.1	4		C283

SOURCE CODE	FEDERAL STOCK NUMBER	DESIGNATION BY MODEL	DESCRIPTION	UNIT OF ISSUE	QTY IN UNIT	DIRECT SUPPORT	GENERAL SUPPORT	DEPOT	ILLUSTRATION	
									FIGURE NO.	ITEM NO.
F	5910-666-7226		R-389/URR (continued) CAPACITOR, FIXED, CERAMIC DIELECTRIC: 300 mmf ± 2%; 500 vdcw; Collins part/dwg 913 1507 00	1	0.2	0.1	4			C285
F	5910-667-5650		CAPACITOR, FIXED, CERAMIC DIELECTRIC: 2 sect 500 mmf ea sect; 500 vdcw; Electro Motive type 605	1	0.2	0.1	6			
F	5910-648-7336		CAPACITOR, FIXED, CERAMIC DIELECTRIC: 1,000 mmf ± 20%; 500 vdcw; Collins part/dwg 913 0371 00	1	0.2	0.1	6			C293
F	5910-275-6430		CAPACITOR, FIXED, CERAMIC DIELECTRIC: 2,000 mmf guarantee min; 500 vdcw; Centralab part DA521-001A (Item Nos: C224, C237, C252, C254 thru C256, C258, C259, C263, C265, C272 thru C274, C279, C280, C288, C289, C292)	18	1.2	0.7	31			See desc column
F	5910-666-7004		CAPACITOR, FIXED, ELECTROLYTIC: 8 mf ± 30 vdc; Fansteel Metalur Cat PP8B30A2	1	0.2	0.1	4			C612
F	5910-280-7413		CAPACITOR, FIXED ELECTROLYTIC: 200 mmf; 50 vdcw; JAN type CE 41C221G	2	0.2	0.1	6			C102 C401
F	5910-395-9311		CAPACITOR, FIXED, GLASS DIELECTRIC: 10,000 mmf ± 2%; 300 vdcw; Collins part/dwg 914 0021 00 (Item Nos: C201, C202, C216, C217, C228, C229, C240, C241)	8	0.7	0.4	17			See desc column
F	5910-194-3018		CAPACITOR, FIXED MICA DIELECTRIC: 18 mmf ± 5%; 500 vdcw; Sig dwg 300-1	1	0.2	0.1	6			C106
F	5910-264-9420		CAPACITOR, FIXED, MICA DIELECTRIC: 22 mmf ± 5%; 500 vdcw; Electro Motive CM15D220J	1	0.2	0.1	6			C269

SOURCE CODE	FEDERAL STOCK NUMBER	DESIGNATION BY MODEL	DESCRIPTION	UNIT OF ISSUE	EXP	QTY IN UNIT	DIRECT SUPPORT	GENERAL SUPPORT	DEPOT	ILLUSTRATION	
										FIGURE NO.	ITEM NO.
A B C D			R-389/URR (continued)								
F	5910-667-5745		CAPACITOR, FIXED, MICA DIELECTRIC: 33 mmf ± 2%; 500 vdcw; Electro Motive CM15D330G			1	0.2	0.1	6		C611
F	5910-666-7863		CAPACITOR, FIXED, MICA DIELECTRIC: 43 mmf ± 2%; 500 vdcw; Electro Motive CM15D430G			1	0.2	0.1	6		C287
F	5910-666-7886		CAPACITOR, FIXED, MICA DIELECTRIC: 47 mmf ± 2%; 500 vdcw; Electro Motive CM15D470G (Item Nos: C267, C209, C260, C262, C512, C533)			6	0.9	0.6	23		See desc column
F	5910-667-5742		CAPACITOR, FIXED, MICA DIELECTRIC: 68 mmf ± 2%; 500 vdcw; Electro Motive CM15D680G			1	0.2	0.1	6		C297
F	5910-666-7859		CAPACITOR, FIXED, MICA DIELECTRIC: 82 mmf ± 2%; 500 vdcw; Electro Motive CM15D820G			2	0.4	0.2	10		C250 C253
F	5910-276-6890		CAPACITOR, FIXED, MICA DIELECTRIC: 91 mmf ± 2%; 500 vdcw; Electro Motive CM15D910G			1	0.2	0.1	4		C296
F	5910-644-6399		CAPACITOR, FIXED, MICA DIELECTRIC: 100 mmf ± 2%; 500 vdcw; S1E dwS SM-C-166405-24 (Item Nos: C264, C268, C270, C286, C502, C532, C551, C711)			8	0.7	0.4	17		See desc column
F	5910-101-5617		CAPACITOR, FIXED, MICA DIELECTRIC: 100 mmf ± 10%; 500 vdcw; MIL type CM20B101K			1	0.2	0.1	4		C607
F	5910-190-8226		CAPACITOR, FIXED, MICA DIELECTRIC: 150 mmf ± 2%; 500 vdcw; Electro Motive CM15D151G			1	0.2	0.1	4		

SOURCE CODE	FEDERAL STOCK NUMBER	DESIGNATION BY MODEL	DESCRIPTION	UNIT OF ISSUE	QTY IN UNIT	DIRECT SUPPORT	GENERAL SUPPORT	DEPT	ILLUSTRATION	
									FIGURE NO.	ITEM NO.
A			R-389/URR (continued)							
B	5910-235-2222		CAPACITOR, FIXED, MICA DIELECTRIC: 180 mmf ±2%; 500 vdcw; Electro Motive CM15D181G		1	0.2	0.1	4		C257
C	5910-270-3187		CAPACITOR, FIXED, MICA DIELECTRIC: 180 mmf ± 5%; 500 vdcw; Sig dwg SC-C-62532-6		1	0.2	0.1	4		C550
D	5910-235-2223		CAPACITOR, FIXED, MICA DIELECTRIC: 200 mmf ± 2%; 500 vdcw; Electro Motive CM15D201G		1	0.2	0.1	4		C706
	5910-229-1752		CAPACITOR, FIXED, MICA DIELECTRIC: 220 mmf ± 2%; 500 vdcw; Electro Motive CM15D221G		1	0.2	0.1	4		C543
	5910-276-6799		CAPACITOR, FIXED, MICA DIELECTRIC: 240 mmf ± 2%; 500 vdcw; Collins part/dwg 912 0520 00		3	0.3	0.2	8		C266 C267 C282
	5910-256-5566		CAPACITOR, FIXED, MICA DIELECTRIC: 330 mmf ± 2%; 500 vdcw; Electro Motive CM15D331G		1	0.2	0.1	4		C205
	5910-191-2639		CAPACITOR, FIXED, MICA DIELECTRIC: 470 mmf ± 2%; 300 vdcw; MIL type CM15D471G		1	0.2	0.1	4		C261
	5910-284-4027		CAPACITOR, FIXED, MICA DIELECTRIC: 560 mmf ± 2%; 500 vdcw; Collins part/dwg 935 5062 00		1	0.2	0.1	4		C212
	5910-667-5660		CAPACITOR, FIXED, MICA DIELECTRIC: 620 mmf ± 2%; 500 vdcw; Electro Motive CM20E621G		3	0.3	0.2	8		C223 C235 C247
	5910-284-4929		CAPACITOR, FIXED, MICA DIELECTRIC: 750 mmf ± 2%; 500 vdcw; Collins part/dwg 935 506 600		1	0.2	0.1	4		C284

SOURCE CODE	FEDERAL STOCK NUMBER	DESIGNATION BY MODEL	DESCRIPTION	UNIT OF ISSUE	EXP	QTY IN UNIT	DIRECT SUPPORT	GENERAL SUPPORT	DEPOT	ILLUSTRATION	
										FIGURE NO.	ITEM NO.
A			R-389/URR (continued)								
B	5910-247-2467		CAPACITOR, FIXED, MICA DIELECTRIC: 820 mmf ± 2%; 500 vdcw; Collins part/dwg 935 5014 00			1	0.2	0.1	4		C210
C	5910-666-7323		CAPACITOR, FIXED, MICA DIELECTRIC: 910 mmf ± 2%; 500 vdcw; Electro Motive CM20E911G			3	0.3	0.2	8		C222 C234 C246
D	5910-276-6797		CAPACITOR, FIXED, MICA DIELECTRIC: 1,100 mmf ± 2%; 300 vdcw; Collins part/dwg 935 5013 00			2	0.2	0.1	6		C206 C208
	5910-667-5557		CAPACITOR, FIXED, MICA DIELECTRIC: 1,200 mmf ± 2%; 500 vdcw; Electro Motive 603M (Item Nos: C220, C221, C232, C233, C244, C245)			6	0.6	0.3	14		See desc column
	5910-101-5782		CAPACITOR, FIXED, MICA DIELECTRIC: 2,000 mmf ± 2%; 500 vdcw; MIL type CM30D202G			1	0.2	0.1	4		C204
	5910-668-4728		CAPACITOR, FIXED, MICA DIELECTRIC: 2,400 mmf ± 2%; 300 vdcw; Electro Motive VCM20E242G--300WV			3	0.3	0.2	8		C219 C231 C243
	5910-184-4513		CAPACITOR, FIXED, MICA DIELECTRIC: 5,100 mmf ± 2%; 500 vdcw; MIL type CM3SE512G (Item Nos: C203, C218, C230, C242)			4	0.4	0.2	10		See desc column
	5910-667-4926		CAPACITOR, FIXED, PAPER DIELECTRIC: 1,500 mmf ± 20%; 300 vdcw; Sprague part 86F15203S1			1	0.2	0.1	4		C602
	5910-666-7219		CAPACITOR, FIXED, CERAMIC DIELECTRIC: 1,880 mmf ± 1%; 500 vdcw; Herlec type B11			1	0.2	0.1	6		C701
	5910-284-4823		CAPACITOR, FIXED, PAPER DIELECTRIC: 2,200 mmf ± 20%; 200 vdcw; Sprague type 96F22202S2			2	0.4	0.2	10		C604 C611

SOURCE CODE	FEDERAL STOCK NUMBER	DESIGNATION BY MODEL	DESCRIPTION	UNIT OF ISSUE	EXP	QTY IN UNIT	DIRECT SUPPORT	GENERAL SUPPORT	DEPOT	ILLUSTRATION	
										FIGURE NO.	ITEM NO.
F	5910-644-0672		R-389/UFR (continued) CAPACITOR, FIXED, PAPER DIELECTRIC: 10,000 mmf ± 20%; 200 vdcw; Sprague type 96P10302S2 (Item Nos: C501, C503, C508, C529, C605)			5	0.5	0.3	12		See desc column
F	5910-667-5383		CAPACITOR, FIXED, PAPER DIELECTRIC: 10,000 mmf ± 20%; 300 vdcw; Sprague type 96P10303S4			17	1.2	0.7	30		See desc column
F	5910-667-5383		CAPACITOR, FIXED, PAPER DIELECTRIC: 10,000 mmf ± 20%; 300 vdcw; Sprague type 96P10303S4			17	1.2	0.7	30		See desc column
F	5910-284-5212		CAPACITOR, FIXED, PAPER DIELECTRIC: 10,000 mmf ± 20%; 300 vdcw; Sprague type 96P10303S4 (Item Nos: C105, C248, C249, C506, C510, C511, C515, C516, C518, C519, C521, C522, C535, C541, C705, C603, C610, C705)			9	0.8	0.5	19		See desc column
F	5910-667-5190		CAPACITOR, FIXED, PAPER DIELECTRIC: 10,000 mmf ± 20%; 300 vdcw; Sprague type 86P10303S1 (Item Nos: C255, C227, C236, C239, C271, C281, C290, C291, C294)			6	0.6	0.3	14		See desc column
F	5910-666-8220		CAPACITOR, FIXED, PAPER DIELECTRIC: 47,000 mmf ± 20%; 200 vdcw; Good-All Elect Mfg type 51SG47302SZ			1	0.2	0.1	4		C527
F	5910-270-5337		CAPACITOR, FIXED, PAPER DIELECTRIC: 47,000 mmf ± 20%; 300 vdcw; Collins part/dw5 931 0440 00			3	0.3	0.2	8		C507 C524 C534

SOURCE CODE	FEDERAL STOCK NUMBER	DESIGNATION BY MODEL	DESCRIPTION	UNIT OF ISSUE	EXP	QTY IN UNIT	DIRECT SUPPORT	GENERAL SUPPORT	DEPOT	ILLUSTRATION	
										FIGURE NO.	ITEM NO.
F	5910-666-8277		R-389/UBR (continued) CAPACITOR, FIXED, PAPER DIELECTRIC: 100,000 mmf ± 20%; 100 vdcw; Sprague type 96P10401S2 (Item Nos: 0504, 0509, 0513, 0514, 0517, 0520, 0523, 0537, 0538, 0545, 0549, 0606)			14	1.0	0.6	26		See descr column
F	5910-284-4014		CAPACITOR, FIXED, PAPER DIELECTRIC: 100,000 mmf ± 20%; 200 vdcw; Sprague type 86P10402S5			1	0.2	0.1	4		0548
F	5910-280-6978		CAPACITOR, FIXED, PAPER DIELECTRIC: 100,000 mmf ± 20%; 300 vdcw; Sprague type 96P10403S2			1	0.2	0.1	4		0531
F	5910-668-3848		CAPACITOR, FIXED, PAPER DIELECTRIC: 100,000 mmf ± 20%; 300 vdcw; Sprague type 86P10403S5 (Item Nos: 0213, 0214, 0530, 0542)			4	0.4	0.2	10		See descr column
F	5910-667-4972		CAPACITOR, FIXED, PAPER DIELECTRIC: 220,000 mmf ± 20%; 400 vdcw; MIL type CP10A1EE224M			1	0.2	0.1	4		0608
F	5910-284-4064		CAPACITOR, FIXED, PAPER DIELECTRIC: 220,000 mmf ± 20%; 100 vdcw; Sprague type 96P22491S2			1	0.2	0.1	4		0528
F	5910-284-4004		CAPACITOR, FIXED, PAPER DIELECTRIC: 220,000 mmf ± 20%; 100 vdcw; Sprague type 96P22401S13			1	0.2	0.1	4		0101
F	5910-262-8522		CAPACITOR, FIXED, PAPER DIELECTRIC: 470,000 mmf ± 20%; 100 vdcw; Collins part/dwg 931 0592 00			2	0.2	0.1	6		0226 0238
F	5910-280-8211		CAPACITOR, FIXED, PAPER DIELECTRIC: 470,000 mmf ± 20%; 300 vdcw; Sprague type 86P47403S5			1	0.2	0.1	4		0295

SOURCE CODE	FEDERAL STOCK NUMBER	DESIGNATION BY MODEL	DESCRIPTION	UNIT OF ISSUE	EXP	QTY IN UNIT	DIRECT SUPPORT	GENERAL SUPPORT	DEPOT	ILLUSTRATION	
										FIGURE NO.	ITEM NO.
A			R-389/URR (continued)								
B	5910-666-8322		CAPACITOR, FIXED, PAPER DIELECTRIC: 1 mf ± 20%; 300 vdcw; Sprague type 86P1050385			2	0.2	0.1	6		0601 0609
C	5910-163-9940		CAPACITOR, FIXED, PAPER DIELECTRIC: 1 mf ± 20% -10%; 400 vdcw MIL type CP61B1EE105V			2	0.2	0.1	6		0546 0547
D	5910-284-4015		CAPACITOR, FIXED, PAPER DIELECTRIC: 1 mf ± 20%; 100 vdcw; Sprague type 86P10501S5			1	0.2	0.1	4		0505
	5910-666-8400		CAPACITOR, FIXED, PAPER DIELECTRIC: 10 mf ± 10%; 300 vdcw; GE type 28F259			1	0.2	0.1	4		0104
	5910-667-5233		CAPACITOR, FIXED, PAPER DIELECTRIC: 10 mf ± 10%; 600 vdcw; Sprague spec P50477			1	0.2	0.1	4		0103
	5910-667-6731		CAPACITOR, VARIABLE, AIR DIELECTRIC: 4.5 to 92.7 mmf; 600v ac; Hammarlund type MAPC-100			1	0.2	0.1	6		0704
	5910-284-5308		CAPACITOR, VARIABLE, CERAMIC: 500 vdcw; Centralab type 822-121			1	0.2	0.1	6		0525
	5910-668-3246		CAPACITOR, VARIABLE, CERAMIC: 5 mmf to 25 mmf; 350 vdcw; Erie part 316NPO5-25 mmf			1	0.2	0.1	6		0251
	5910-392-6821		CAPACITOR, KIT: incl tuning capacitors; plastic bag; Collins part/dwg 506 7072 002			1	0.2	0.1	6		0702 0703
	5950-395-9255		COIL, RADIOFREQUENCY: 2.2 uh at 250 kc; Collins part/dwg 240 0136 00			1	0.2	0.1	6		L304
	5950-219-9798		COIL, RADIOFREQUENCY: 12 uh at 150 kc; Nat'l Coil part C0047140			1	0.2	0.1	6		L502

SOURCE CODE	FEDERAL STOCK NUMBER	DESIGNATION BY MODEL	DESCRIPTION	UNIT OF ISSUE	EXP	QTY IN UNIT	DIRECT SUPPORT	GENERAL SUPPORT	DEPOT	ILLUSTRATION	
										FIGURE NO.	ITEM NO.
A B C D			R-389/URR (continued)								
F	5950-395-9256		COIL, RADIOFREQUENCY: 10 uh at 2.5 mc; Collins part/dwg 240 0099 00			1	0.2	0.1	6		L702
F	5950-387-0489		COIL, RADIOFREQUENCY: 3 pic Universal wrd; 500 uh at 790 kc; Nat'l Coil part C-0047109 (Item Nos: L286, L294, L295, L501, L503)			5	0.8	0.5	20		See desc column
F	5950-395-9257		COIL, RADIOFREQUENCY: Collins part/dwg 506 8079 003			1	0.2	0.1	6		L701
F	5930-301-4572		COMMUTATOR AND CONNECTOR ASSEMBLY: ARF part 1C88			1	0.2	0.1	6		S205
F	5935-636-9878		CONNECTOR, PLUG, ELECTRICAL: 1 rd female cont; Collins part/dwg 357 9163 00			1	0.2	0.1	6		P230
F	5935-259-0820		CONNECTOR, PLUG, ELECTRICAL: 1 rd male cont; Collins part/dwg 357 9143 00 (Item Nos: P209, P210, P211, P223 thru P226, P730)			8	1.1	0.7	28		See desc column
F	5935-149-4013		CONNECTOR, PLUG, ELECTRICAL: 2 flat male cont; Hubbell part 7057			1	0.2	0.1	6		
F	5935-201-7905		CONNECTOR, PLUG, ELECTRICAL: 4 rd female cont; Amphenol part 164-42FS			1	0.2	0.1	6		
F	5935-295-5006		CONNECTOR, PLUG, ELECTRICAL: 15 rd male cont; Amphenol part 26-151			1	0.2	0.1	6		J619
F	5935-258-9989		CONNECTOR, RECEPTACLE, ELECTRICAL: 1 rd female cont; Collins part/dwg 357 9165 00			1	0.2	0.1	6		J104
F	5935-222-0850		CONNECTOR, RECEPTACLE, ELECTRICAL: 1 rd female cont; Johnson EF type 105-520			2	0.4	0.2	10		J232 J601

SOURCE CODE	FEDERAL STOCK NUMBER	DESIGNATION BY MODEL	DESCRIPTION	UNIT OF ISSUE	EXP	QTY IN UNIT	DIRECT SUPPORT	GENERAL SUPPORT	DEPOT	ILLUSTRATION	
										FIGURE NO.	ITEM NO.
F	5935-259-1087		R-389/UFR (continued) CONNECTOR, RECEPTACLE, ELECTRICAL: 1 rd female cont; Sig dwg SC-B-41141 (Item Nos: J109, J110, J111, J223, J224, J512, J525, J526			8	1.1	0.7	28		See desc column
F	5935-665-4573		CONNECTOR, RECEPTACLE, ELECTRICAL UG-422/U: 2 rd female cont; MIL-Spec-MIL-C-3655			1	0.2	0.1	6		J106
F	5935-258-8170		CONNECTOR, RECEPTACLE, ELECTRICAL: 7 rd female cont; Amphenol part 26-192			1	0.2	0.1	4		J131
F	5935-636-5913		CONNECTOR, RECEPTACLE, ELECTRICAL: 7 rd male cont; Amphenol part 26-191			1	0.2	0.1	4		P731
F	5935-511-6536		CONNECTOR, RECEPTACLE, ELECTRICAL: 9 rd female cont; Collins part/dwg 372 1127 00			1	0.2	0.1	4		J103
F	5935-259-6798		CONNECTOR, RECEPTACLE, ELECTRICAL: 11 rd male cont; Amphenol part 26-804			3	0.3	0.2	8		J228 J423 J620
F	5935-198-9608		CONNECTOR, RECEPTACLE, ELECTRICAL: 14 rd female cont; Winchester Electronics part MRE14S-G			3	0.3	0.2	8		P129 P221 P222
F	5935-258-1709		CONNECTOR, RECEPTACLE, ELECTRICAL: 14 rd male cont; Winchester Electronics part MRE14P-G			3	0.3	0.2	8		P221 P222 J229
F	5935-258-9143		CONNECTOR, RECEPTACLE, ELECTRICAL: 20 rd female cont; Amphenol type 126-810			2	0.2	0.1	6		P117 P127
F	5935-173-5908		CONNECTOR, RECEPTACLE, ELECTRICAL: 20 rd male cont; Amphenol part 26-806			2	0.4	0.2	10		J227 J517

SOURCE CODE	FEDERAL STOCK NUMBER	DESIGNATION BY MODEL	DESCRIPTION	UNIT OF ISSUE	EXP	QTY IN UNIT	DIRECT SUPPORT	GENERAL SUPPORT	DEPOT	ILLUSTRATION	
										FIGURE NO.	ITEM NO.
A			R-389/URR (continued)								
F	5935-201-3998		CONNECTOR, RECEPTACLE, ELECTRICAL: MIL type CS-2020 (1) (P)			1	0.2	0.1	6		J102
F	5935-283-7134		CONNECTOR, RECEPTACLE, ELECTRICAL UG-568/U: MIL Std - MS-35319			1	0.2	0.1	6		J105
F	5950-646-3175		CORE, ADJUSTABLE TUNING: tuning slugs for T-201, T208, Z201, Z208; 14 to 28 kc freq range; Collins part/dwg 506 7917 002			1	0.4	0.2	10		
F	5950-646-3173		CORE, ADJUSTABLE TUNING: tuning slugs for T203, T210, T202, T209, Z203, Z210, Z202, Z209; 26 to 126 kc freq range; Collins part/dwg 506 7918 002			8	0.7	0.4	17		
F	5950-646-3179		CORE, ADJUSTABLE TUNING: tuning slugs for T-204, T-211, Z204, Z211; 115 to 245 kc freq range; Collins part/dwg 506 7919 002			4	0.4	0.2	10		
F	5950-646-3174		CORE, ADJUSTABLE TUNING: tuning slugs for T205, T-212, Z205, Z212; 240 to 505 kc freq range Collins part/dwg 506 7920 002			4	0.4	0.2	10		
F	5950-646-3177		CORE, ADJUSTABLE TUNING: tuning slugs for T206, T213, Z206, Z213; 495 kc to 870 kc freq range Collins part/dwg 506 7921 00			4	0.4	0.2	10		
F	5950-646-3176		CORE, ADJUSTABLE TUNING: tuning slugs for T-207, T214, Z207, Z214; 860 to 1505 kc freq range; Collins part/dwg 506 7922 002			4	0.4	0.2	10		
F	5950-645-8798		CORE, ADJUSTABLE TUNING: tuning slugs for Z217, Z218; 450 to 2000 kc freq range; Collins part/dwg 506 7923 00			2	0.2	0.1	6		

SOURCE CODE	FEDERAL STOCK NUMBER	DESIGNATION BY MODEL	DESCRIPTION	UNIT OF ISSUE	EXP	QTY IN UNIT	DIRECT SUPPORT	GENERAL SUPPORT	DEPOT	ILLUSTRATION	
										FIGURE NO.	ITEM NO.
A			R-389/URR (continued)								
			CORE, ADJUSTABLE TUNING: tuning slugs for Z215, Z216, Z219, Z220; Collins part/dwg 506 7924 002			4	0.4	0.2	10		
F	5950-646-3178										
F	6680-510-4803		COUNTER, MECHANICAL: rotary wheel type; 8 wheels ea wheel numbered 1 to 10; Veeder Root part A-148904	NX		1	0.2	0.1	6		M201
O	5955-537-4027		CRYSTAL UNIT, QUARTZ CR-18/U: 10,455 kc; MIL-spec-MIL-C-3098	NX		1	0.2	0.1	4		Y201
O	5955-250-0568		CRYSTAL UNIT, QUARTZ CR-45/U: MIL spec MIL-C-3098	NX		1	0.2	0.1	4		Y501
F	5930-258-4233		DETENT SWITCH: non-adjustable; Collins part/dwg 269 1453 00			1	0.2	0.1	4		O501
O	5960-188-3551		ELECTRON TUBE: MIL type 6AK6			3	52.5	31.5	131		V506 V603 V604
O	5960-264-3002		ELECTRON TUBE: MIL type 5750/6BE6W			3	26.2	15.7	657		V205 V212 V213
O	5960-188-3602		ELECTRON TUBE: MIL type 6BH6 (Item Nos: V206 thru V209, V211, V607, V702)			7	35.0	21.0	875		See desc column
O	5960-188-6589		ELECTRON TUBE: MIL type 6BJ6 (Item Nos: V202, V203, V501 thru V505, V509)			8	70.0	42.0	1752		See desc column
O	5960-235-8215		ELECTRON TUBE: MIL type 6C4W			2	17.6	10.5	438		V210
O	5960-262-0167		ELECTRON TUBE: MIL type 12AT7WA			2	17.6	10.5	438		V204 V602
O	5960-262-0210		ELECTRON TUBE: MIL type 5814A (Item Nos: V507, V510, V511, V601)			4	17.6	10.5	438		See desc column

SOURCE CODE	FEDERAL STOCK NUMBER	DESIGNATION BY MODEL	DESCRIPTION	UNIT OF ISSUE	EXP	QTY IN UNIT	DIRECT SUPPORT	GENERAL SUPPORT	DEPOT	ILLUSTRATION	
										FIGURE NO.	ITEM NO.
			R-389/URR (continued)								
O	5960-262-0286		ELECTRON TUBE: MIL type 5651WA			2	11.7	7.01	292		V608 V609
O	5960-264-2089		ELECTRON TUBE: MIL type 5749/6BA6W			2	7.00	4.20	175		V508 V701
O	5960-264-1486		ELECTRON TUBE: 6082 Buships spec			2	11.7	7.00	292		V605 V606
F	5915-636-2506		FILTER, BAND PASS: 565 to 1035 cps; 600 ohm input and output; Chic Trans type 15854			1	0.2	0.1	4		FL601
F	5915-504-7116		FILTER, LOW PASS: 3500 kc; 600 ohm input and output Chic Transf type 15289			1	0.2	0.1	4		FL602
F	5915-393-1780		FILTER, LOW PASS: 10,455 kc; Collins part/dwg 241 0135 009			1	0.2	0.1	4		FL201
O	5920-280-8628		FUSE, CARTRIDGE: 3/8 amp; 250 v; renewable; Buss Mfg Co type AGC3-8			1	5.2	3.1	130		F102
O	5920-131-9821		FUSE, CARTRIDGE: 3 amp; 125 v; renewable; Littelfuse part 313003			1	5.2	3.1	130		F101
O	5920-131-9915		FUSE, CARTRIDGE: 20 amp; 32 v; MIL-F-15160 type FO4A20ROA			1	5.2	3.1	130		F103
F	5920-280-4167		FUSEHOLDER: extractor post type; Littelfuse part 342003			3	0.3	0.2	8		XF101 XF102 XF103
F	5820-537-3573		GEAR ASSEMBLY: gear plate; Collins part/dwg 506 6833 004			1	0.2	0.1	4		
F	5820-546-5292		GEAR ASSEMBLY: actuates the tuning rack; Collins part/dwg 506 7635 003			1	0.2	0.1	4		
F	5820-571-4147		GEAR ASSEMBLY: actuates the tuning rack; Collins part/dwg 506 7636 003			1	0.2	0.1	4		

SOURCE CODE	FEDERAL STOCK NUMBER	DESIGNATION BY MODEL	DESCRIPTION	UNIT OF ISSUE	EXP	QTY IN UNIT	DIRECT SUPPORT	GENERAL SUPPORT	DEPOT	ILLUSTRATION	
										FIGURE NO.	ITEM NO.
A			R-389/URR (continued)								
B											
C											
D											
F	5820-203-1526		GEAR, HELICAL: bronze; straight face; 18 rh helical teeth; tuning system; Collins part/dwg 506 7573 002			2	0.2	0.1	6		0337 0338
F	5820-203-1525		GEAR, HELICAL: bronze; straight face; 24 rh helical teeth, tuning system; Collins part/dwg 506 7580 002			2	0.2	0.1	6		0345 0346
F	5820-203-1524		GEAR, HELICAL: bronze; straight face; 32 rh helical teeth, tuning system; Collins part/dwg 506 7583 002			2	0.2	0.1	6		0351 thru 0354
F	5820-534-2845		GEAR, HELICAL: bronze; straight face; 38 rh teeth; tuning system; Collins part/dwg 506 7596 002			2	0.2	0.1	6		0339 0340
F	5820-203-1529		GEAR, WORM: bronze; straight face; 34 rh helical teeth; tuning system Collins part/dwg 506 7575 002			2	0.2	0.1	6		0341 0342
F	5820-269-0092		GEAR, WORM: bronze; straight face; 34 rh helical teeth; tuning system Collins part/dwg 506 7578 002			2	0.2	0.1	6		0343 0344
F	5820-534-2844		GEAR, WORM: bronze; straight face; 41 rh helical teeth; tuning system; Collins part/dwg 506 7582 002			2	0.2	0.1	6		0347 0348
F	5820-545-7560		GEAR, WORM: bronze; straight face; 33 rh helical teeth; tuning system; Collins part/dwg 506 7577 002			2	0.2	0.1	6		0349 0350
F	5935-259-3318		INSERT, ELECTRICAL CONNECTOR: 11 rd female cont; Amphenol part 26-805			3	0.3	0.1	8		P116 P120 P128
F	5935-189-6245		INSERT, ELECTRICAL CONNECTOR: 15 rd female cont; Amphenol part 26-150			2	0.2	0.1	6		P118 P119
F	5935-283-1269		JACK, TELEPHONE JJ-034			1	0.2	0.1	4		J101

SOURCE CODE	FEDERAL STOCK NUMBER	DESIGNATION BY MODEL	DESCRIPTION	UNIT OF ISSUE	EXP	QTY IN UNIT	DIRECT SUPPORT	GENERAL SUPPORT	DEPOT	ILLUSTRATION	
										FIGURE NO.	ITEM NO.
A			R-389/URR (continued)								
	5935-502-4905		JACK, TIP: blk plastic cap; Johnson EF part 105-524			1	0.2	0.1	6		J237
	5935-259-4016		JACK TIP: brown plastic cap; Johnson EF part/dwg 105-524			1	0.2	0.1	6		J231
	5935-258-9892		JACK TIP: yellow nylon ins cap; Johnson EF part 105-527			1	0.2	0.1	6		J234
	5935-259-9663		JACK, TIP: orange plastic cap; Johnson EF part 105-526			1	0.2	0.1	6		J233
	5355-667-9084		KNOB: rd; blk; 2 3/4 in dia by 1 1/4 in thk; Collins part/dwg 5068130002			1	*	0.1	4		
	5355-667-9338		KNOB: bar; blk; 3/4 in lg x 15/16 in dia; Collins part/dwg 281 009 300			8	*	0.4	17		
	5355-665-1307		KNOB: bar; blk; 7/8 in lg x 1 1/8 in dia; Sig dwg SC-C-176385			7	*	0.6	15		
5	6240-179-1812		LAMP, GLOW: GE type NE48			1	0.2	0.1	4		I103
	6240-155-7836		LAMP, INCANDESCENT: 28v, 0.04 amp; midget flange base; Fed Spec W-L-1116 trade 327			2	2.9	1.7	72		I201 I202
	5305-393-2047		LEADSCREW ASSEMBLY: for RF tuner and transf cores; Collins part/dwg 506 7598 002			14	1.0	0.6	26		
	5305-393-2048		LEADSCREW ASSEMBLY: for mixer transf and tuner cores; Collins part/dwg 506 7600 002			1	0.2	0.1	4		
	5305-393-2049		LEADSCREW, ASSEMBLY: for mixer transf and tuner cores; Collins part/dwg 506 7601 002			1	0.2	0.1	4		
	5305-393-2050		LEADSCREW ASSEMBLY: for mixer transf and tuner cores; Collins part/dwg 506 7603 002			1	0.2	0.1	4		

SOURCE CODE	FEDERAL STOCK NUMBER	DESIGNATION BY MODEL	DESCRIPTION	UNIT OF ISSUE	EXP	QTY IN UNIT	DIRECT SUPPORT	GENERAL SUPPORT	DEPOT	ILLUSTRATION	
										FIGURE NO.	ITEM NO.
A			R-389/URR (continued)								
B			LEADSCREW ASSEMBLY: for mixer transf and tuner cores; Collins part/dwg 506 7604 002			14	1.0	0.6	26		
C	5305-393-2051		METER, AUDIO LEVEL: 0 to 3 CW, 0 to 20 CW; Collins part/dwg 481000 100		NX	1	0.3	0.2	8		M101
D	6625-669-0769		METER, AUDIO LEVEL: 0 to 100 CW graduated in 10 scale div; QVS Inc part 14-893635		NX	1	0.3	0.2	8		M102
	6105-324-9078		MOTOR, DIRECT CURRENT: 27.5 v input; 30 to 36 rpm; Globe Industries type CA-27A-500		NX	1	0.2	0.1	4		B201
	6105-521-0412		MOTOR, UNIVERSAL: Series wnd type; 26.5v ac nom; 60 cps; 0.42 amp; GE type 5P14GA2		NX	1	0.2	0.1	4		B202
	5820-503-1195		OSCILLATOR, RADIOFREQUENCY: VFO; 469 to 980 kc range dc; 180 v, 300 ma, 6.3 v 300 ma; Collins part/dwg 506 8086 004		NX	1	0.2	0.1	4		
	5820-503-1202		OVEN, TUNED CIRCUIT: 75° c to 84° c ± 3.5° c to 1; Collins part/dwg 506 8080 003			1	0.2	0.1	4		HR701
	5820-534-2957		POWER SUPPLY: metallic type; output 27v dc unregulated; input 115/230v ac, 48/62 cyc lph; 16.8 va; Collins part/dwg 506 7741 004		NX	1	0.2	0.1	4		
	5950-295-7304		REACTOR: 4 hv, 50 ma dc, 100 ohm dc resistance; hs; Ch1 Trans part 17613			1	0.2	0.1	4		L601
	5820-395-9056		RECEIVER SUBASSEMBLY: tuning motor dr; Collins part/dwg 506 6830 003		NX	1	0.2	0.1	4		

SOURCE CODE	FEDERAL STOCK NUMBER	DESIGNATION BY MODEL	DESCRIPTION	UNIT OF ISSUE	EXP	QTY IN UNIT	DIRECT SUPPORT	GENERAL SUPPORT	DEPOT	ILLUSTRATION	
										FIGURE NO.	ITEM NO.
A			R-389/URR (continued)								
			RECEIVER SUBASSEMBLY: 6 v, 17 ohm, brass case; c/o balanced, unbalanced amt relay and sw; Collins part/dwg 506 8150 004		NX	1	0.2	0.1	4		
F	5820-393-1362		RECTIFIER, METALLIC: Selenium; 1 ph full wave bridge; 28 v ac input; 27 v dc output; GE type 6RS216B2-BA2			1	0.2	0.1	6		CR401
F	6130-511-6678		RELAY, ARMATURE: triple break; low level audio or rf; 1 wnd; 30 ohm dc; 7 v; Collins part/dwg 410 0091 00			1	0.2	0.1	4		K101
F	5945-521-0213		RELAY, ARMATURE: 1A/2C; 27.5 v dc; 5 amp; AEMCO type R45L-2248			1	0.2	0.1	4		K201
F	5945-295-3161		RELAY, ARMATURE: 1 c; 28 v dc; 1 amp; Allied Control SWHX-11			1	0.2	0.1	6		K601
F	5945-665-7485		RELAY, ARMATURE: 1A; 115v ac max, 3 amp nom; Collins part/dwg 972 1260 00			1	0.2	0.1	6		K602
F	5945-259-5831		RESISTOR, CURRENT REGULATING: for ac and dc use; 10.2 v, 0.04 to 0.26 amp; MIL type J311M			1	1.3	0.8	33		RT51L2
O	5905-502-4840		RESISTOR, FIXED, COMPOSITION: 22 ohm ± 10%; 1/2 w; MIL type RC20GF220K			1	0.2	0.1	4		R633
F	5905-252-2995		RESISTOR, FIXED, COMPOSITION: 22 ohm ± 10%; 2 w; MIL type RC42GF220K			1	0.2	0.1	4		R565
F	5905-279-4312		RESISTOR, FIXED, COMPOSITION: 27 ohm ± 10%; 1/2 w; MIL type RC20GF270K			1	0.2	0.1	4		R559
F	5905-251-7757		RESISTOR, FIXED, COMPOSITION: 27 ohm ± 10%; 2 w; MIL type RC42GF270K			1	0.2	0.1	4		R635
F	5905-279-1925					1	0.2	0.1	4		

SOURCE CODE	FEDERAL STOCK NUMBER	DESIGNATION BY MODEL	DESCRIPTION	UNIT OF ISSUE	EXP	QTY IN UNIT	DIRECT SUPPORT	GENERAL SUPPORT	DEPOT	ILLUSTRATION	
										FIGURE NO.	ITEM NO.
A			R-389/URR (continued)								
F	5905-171-2002		RESISTOR, FIXED, COMPOSITION: 47 ohm ± 10%; 1/2 w; MIL type RC20GF470K			1	0.2	0.1	4		R282
F	5905-247-9329		RESISTOR, FIXED, COMPOSITION: 47 ohm ± 10%; 2 w; MIL type RC42GF470K			4	0.4	0.2	10		R619 thru R622
F	5905-252-5428		RESISTOR, FIXED, COMPOSITION: 68 ohm ± 10%; 1/2 w; MIL type RC20GF680K			1	0.2	0.1	4		R550
F	5905-186-3008		RESISTOR, FIXED, COMPOSITION: 100 ohm ± 10%; 1/2 w; MIL type RC20GF101K (Item Nos: R217, R236, R268, R269, R277, R290, R300)			7	0.6	0.4	15		See desc column
F	5905-101-7653		RESISTOR, FIXED, COMPOSITION: 120 ohm ± 10%; 1 w; MIL type RC32GF121K			2	0.2	0.1	6		R563 R564
F	5905-279-1756		RESISTOR, FIXED, COMPOSITION: 150 ohm ± 10%; 1/2 w; MIL type RC20GF151K			1	0.2	0.1	4		R267
F	5905-279-3513		RESISTOR, FIXED, COMPOSITION: 220 ohm ± 5%; 1/2 w; MIL type RC20GF221J			2	0.2	0.1	6		R253 R254
F	5905-256-0409		RESISTOR, FIXED, COMPOSITION: 220 ohm ± 10%; 1/2 w; MIL type RC20GF221K			2	0.2	0.1	6		R280 R518
F	5905-185-6966		RESISTOR, FIXED, COMPOSITION: 270 ohm ± 10%; 1/2 w; MIL type RC20GF271K			1	0.2	0.1	4		R552
F	5905-171-1997		RESISTOR, FIXED, COMPOSITION: 330 ohm ± 5%; 1/2 w; MIL type RC20GF331J (Item Nos: R284, R517, R526, R531)			4	0.4	0.2	10		See desc column

SOURCE CODE	FEDERAL STOCK NUMBER	DESIGNATION BY MODEL	DESCRIPTION	UNIT OF ISSUE	QTY IN UNIT	DIRECT SUPPORT	GENERAL SUPPORT	DEPT	ILLUSTRATION	
									FIGURE NO.	ITEM NO.
A										
B										
C										
D										
F	5905-192-3972		R-389/URR (continued) RESISTOR, FIXED, COMPOSITION: 390 ohm \pm 10%; 1/2 w; MIL type RC20GF391K		1	0.2	0.1	4		R549
F	5905-171-2005		RESISTOR, FIXED, COMPOSITION: 470 ohm \pm 10%; 1/2 w; MIL type RC20GF471K		2	0.2	0.1	6		R297 R298
F	5905-279-2603		RESISTOR, FIXED, COMPOSITION: 470 ohm \pm 10%; 1 w; MIL type RC32GF471K		3	0.3	0.2	8		R554 R608 R632
F	5905-256-0387		RESISTOR, FIXED, COMPOSITION: 680 ohm \pm 10%; 1/2 w; MIL type RC20GF681K		3	0.3	0.2	8		R602 R604 R628
F	5905-257-2631		RESISTOR, FIXED, COMPOSITION: 820 ohm \pm 10%; 1/2 w; MIL type RC20GF821K		3	0.3	0.2	8		R127 R264 R536
F	5905-279-3509		RESISTOR, FIXED, COMPOSITION: 910 ohm \pm 5%; 1/2 w; MIL type RC20GF911J		1	0.2	0.1	4		R519
F	5905-195-6806		RESISTOR, FIXED, COMPOSITION: 1000 ohm \pm 5%; 1/2 w; MIL type RC20GF102J (Item Nos: R239, R240, R242, R243, R245, R246, R248, R249, R251, R252, R256, R257, R293, R294)		14	1.0	0.6	26		See desc column
F	5905-195-6817		RESISTOR, FIXED, COMPOSITION: 1000 ohm \pm 10%; 1/2 w; MIL type RC20GF102K (Item Nos: R274, R503, R510, R538, R625)		5	0.5	0.3	12		See desc column
F	5905-279-1722		RESISTOR, FIXED, COMPOSITION: 1000 ohm \pm 10%; 1 w; MIL type RC32GF102K		3	0.3	0.2	8		R201 R202 R618
F	5905-195-6809		RESISTOR, FIXED, COMPOSITION: 1200 ohm \pm 10%; 1/2 w; MIL type RC20GF122K		1	0.2	0.1	4		R119

SOURCE CODE	FEDERAL STOCK NUMBER	DESIGNATION BY MODEL	DESCRIPTION	UNIT OF ISSUE	EXP	QTY IN UNIT	DIRECT SUPPORT	GENERAL SUPPORT	DEPOT	ILLUSTRATION	
										FIGURE NO.	ITEM NO.
A B C D			R-389/URR (continued)								
F	5905-195-6741		RESISTOR, FIXED, COMPOSITION: 2700 ohm ± 10%; 1/2 w; MIL type RC20GF272K			1	0.2	0.1	4		R561
F	5905-195-6502		RESISTOR, FIXED, COMPOSITION: 3300 ohm ± 10%; 1/2 w; MIL type RC20GF332K			1	0.2	0.1	4		R561
F	5905-195-5514		RESISTOR, FIXED, COMPOSITION: 1500 ohm ± 10%; 1/2 w; MIL type RC20GF152K			2	0.2	0.1	6		R258 R259
F	5905-279-2672		RESISTOR, FIXED, COMPOSITION: 1800 ohm ± 10%; 1/2 w; MIL type RC20GF182K			1	0.2	0.1	4		R285
F	5905-552-5057		RESISTOR, FIXED, COMPOSITION: 1800 ohm ± 10%; 1 w; MIL type RC32GF182K			1	0.2	0.1	4		R281
F	5905-171-2009		RESISTOR, FIXED, COMPOSITION: 2200 ohm ± 10%; 1/2 w; MIL type RC20GF222K (Item Nos: R506, R513, R523, R528, R533, R548, R705, R603, R634)			9	0.8	0.5	19		See desc column
F	5905-195-6741		RESISTOR, FIXED, COMPOSITION: 2700 ohm ± 10%; 1/2 w; MIL type RC20GF272K			1	0.2	0.1	4		R626
F	5905-279-3506		RESISTOR, FIXED, COMPOSITION: 3300 ohm ± 5%; 1/2 w; MIL type RC20GF332J			1	0.2	0.1	4		R203
F	5905-195-6502		RESISTOR, FIXED, COMPOSITION: 3300 ohm ± 10%; 1/2 w; MIL type RC20GF332K			1	0.2	0.1	4		R286
F	5905-279-3505		RESISTOR, FIXED, COMPOSITION: 3900 ohm ± 5%; 1/2 w; MIL type RC20GF392J (Item Nos: R206 thru R209, R227, R521)			6	0.6	0.3	14		See desc column
F	5905-279-3504		RESISTOR, FIXED, COMPOSITION: 4700 ohm ± 5%; 1/2 w; MIL type RC20GF472J			1	0.2	0.1	4		R225

SOURCE CODE	FEDERAL STOCK NUMBER	DESIGNATION BY MODEL	DESCRIPTION	UNIT OF ISSUE	EXP	QTY IN UNIT	DIRECT SUPPORT	GENERAL SUPPORT	DEPOT	ILLUSTRATION	
										FIGURE NO.	ITEM NO.
A			R-389/URR (continued)								
B	5905-279-2019		RESISTOR, FIXED, COMPOSITION: 5100 ohm \pm 5%; 1/2 w; MIL type RC20GF512J			1	0.2	0.1	4		R520
C	5905-195-6453		RESISTOR, FIXED, COMPOSITION: 5600 ohm \pm 5%; 1/2 w; MIL type RC20GF562J			3	0.3	0.2	8		R205 R232 R233
D	5905-279-3503		RESISTOR, FIXED, COMPOSITION: 6800 ohm \pm 5%; 1/2 w; MIL type RC20GF682J (Item Nos: R224, R226, R229, R231)			4	0.4	0.2	10		See desc column
	5905-245-0023		RESISTOR, FIXED, COMPOSITION: 6800 ohm \pm 10%; 1/2 w; MIL type RC20GF682K			1	0.2	0.1	4		R128
	5905-299-1971		RESISTOR, FIXED, COMPOSITION: 8200 ohm \pm 5%; 1/2 w; MIL type RC20GF822J			2	0.2	0.1	6		R228 R230
	5905-171-1985		RESISTOR, FIXED, COMPOSITION: 8200 ohm \pm 10%; 1/2 w; MIL type RC20GF822K			1	0.2	0.1	4		R288
	5905-185-8510		RESISTOR, FIXED, COMPOSITION: 10000 ohm \pm 5%; 1/2 w; MIL type RC20GF103J			1	0.2	0.1	4		R247
	5905-299-2029		RESISTOR, FIXED, COMPOSITION: 10000 ohm \pm 10%; 1 w; MIL type RC32GF103K			1	0.2	0.1	4		R703
	5905-279-3502		RESISTOR, FIXED, COMPOSITION: 12000 ohm \pm 5%; 1/2 w; MIL type RC20GF123J (Item Nos: R204, R223, R244, R255)			4	0.4	0.2	10		See desc column
	5905-249-4217		RESISTOR, FIXED, COMPOSITION: 15000 ohm \pm 10%; 2 w; MIL type RC42GF153K			1	0.2	0.1	4		R299
	5905-279-3500		RESISTOR, FIXED, COMPOSITION: 18000 ohm \pm 5%; 1/2 w; MIL type RC20GF183J			1	0.2	0.1	4		R250

SOURCE CODE	FEDERAL STOCK NUMBER	DESIGNATION BY MODEL	DESCRIPTION	UNIT OF ISSUE	EXP	QTY IN UNIT	DIRECT SUPPORT	GENERAL SUPPORT	DEPOT	ILLUSTRATION	
										FIGURE NO.	ITEM NO.
F	5905-249-4227		R-389/URR (continued) RESISTOR, FIXED, COMPOSITION: 18000 ohm ± 10%; 2 w; MIL type RC42GF183K			2	0.2	0.1	6		R218 R237
F	5905-171-2004		RESISTOR, FIXED, COMPOSITION: 22000 ohm ± 5%; 1/2 w; MIL type RC20GF223J			1	0.2	0.1	4		R292
F	5905-279-2029		RESISTOR, FIXED, COMPOSITION: 32000 ohm ± 10%; 1/2 w; MIL type RC20GF223K (Item Nos: R215, R235, R501, R509, R532)			5	0.5	0.3	12		See desc column
F	5905-299-2019		RESISTOR, FIXED, COMPOSITION: 22000 ohm ± 5%; 2 w; MIL type RC32GF223K			1	0.2	0.1	4		R547
F	5905-279-3499		RESISTOR, FIXED, COMPOSITION: 27000 ohm ± 5%; 1/2 w; MIL type RC20GF273J			2	0.2	0.1	6		R211 R222
F	5905-195-6758		RESISTOR, FIXED, COMPOSITION: 27000 ohm ± 10%; 1/2 w; MIL type RC20GF273K (Item Nos: R271, R504, R539, R540)			4	0.4	0.2	10		See desc column
F	5905-249-4248		RESISTOR, FIXED, COMPOSITION: 33000 ohm ± 10%; 1/2 w; MIL type RC20GF333K			1	0.2	0.1	4		R546
F	5905-279-3497		RESISTOR, FIXED, COMPOSITION: 39000 ohm ± 5%; 1/2 w; MIL type RC20GF393J			2	0.2	0.1	6		R241 R291
F	5905-254-9201		RESISTOR, FIXED, COMPOSITION: 47000 ohm ± 5%; 1/2 w; MIL type RC20GF473J			2	0.2	0.1	6		R210 R220
F	5905-295-3410		RESISTOR, FIXED, COMPOSITION: 47000 ohm ± 10%; 1/2 w; MIL type RC20GF473K			2	0.2	0.1	6		R502 R553
F	5905-299-2014		RESISTOR, FIXED, COMPOSITION: 47000 ohm ± 10%; 1 w; MIL type RC32GF473K (Item Nos: R219, R238, R265, R505, R511,			5	0.5	0.3	12		See desc column

SOURCE CODE	FEDERAL STOCK NUMBER	DESIGNATION BY MODEL	DESCRIPTION	UNIT OF ISSUE	EXP	QTY IN UNIT	DIRECT SUPPORT	GENERAL SUPPORT	DEPOT	ILLUSTRATION	
										FIGURE NO.	ITEM NO.
A			R-389/URR (continued)								
B	5905-192-3988		RESISTOR, FIXED, COMPOSITION: 56000 ohm \pm 10%; 1/2 w; MIL type RC20GF563K			1	0.2	0.1	4		R103
C	5905-299-2012		RESISTOR, FIXED, COMPOSITION: 56000 ohm \pm 10%; 1 w; MIL type RC32GF563K			1	0.2	0.1	4		R617
D	5905-195-6756		RESISTOR, FIXED, COMPOSITION: 56000 ohm \pm 10%; 2 w; MIL type RC42GF563K			2	0.2	0.1	6		R560 R613
	5905-299-2007		RESISTOR, FIXED, COMPOSITION: 68000 ohm \pm 10%; 1 w; MIL type RC32GF683K			1	0.2	0.1	4		R702
	5905-537-6463		RESISTOR, FIXED, COMPOSITION: 82000 ohm \pm 10%; 1 w; MIL type RC32GF823K			2	0.2	0.1	6		R616 R629
	5905-192-3987		RESISTOR, FIXED, COMPOSITION: 100000 ohm \pm 10%; 1/2 w; MIL type RC20GF104K (Item Nos: R126, R263, R270, R272, R275, R276, R278, R279, R283, R287, R295, R296, R522, R527, R555, R704)			16	1.1	0.7	28		See desc column
	5905-192-9260		RESISTOR, FIXED, COMPOSITION: 150,000 ohm \pm 10%; 1/2 w; MIL type RC20GF154K			2	0.2	0.1	6		R545 R701
	5905-192-0662		RESISTOR, FIXED, COMPOSITION: 180000 ohm \pm 10%; 1/2 w; MIL type RC20GF184K			2	0.2	0.1	6		R556 R605
	5905-295-3409		RESISTOR, FIXED, COMPOSITION: 220,000 ohm \pm 10%; 1/2 w; MIL type RC20GF224K (Item Nos: R214, R234, R512, R557)			4	0.4	0.2	10		See desc column
	5905-221-5860		RESISTOR, FIXED, COMPOSITION: 330,000 ohm \pm 10%; 1/2 w; MIL type RC20GF334K			2	0.2	0.1	6		R273 R630

SOURCE CODE	FEDERAL STOCK NUMBER	DESIGNATION BY MODEL	DESCRIPTION	UNIT OF ISSUE	EXP	QTY IN UNIT	DIRECT SUPPORT	GENERAL SUPPORT	DEPOT	ILLUSTRATION	
										FIGURE NO.	ITEM NO.
A			R-389/URR (continued)								
B	5905-537-6461		RESISTOR, FIXED, COMPOSITION: 330,000 ohm \pm 10%; 2 w; MIL type RC42GF34K			1	0.2	0.1	4		R615
C	5905-185-6946		RESISTOR, FIXED, COMPOSITION: 470,000 ohm \pm 10%; 1/2 w; MIL type RC20GF47K (Item Nos: R541, R544, R606, R607, R631)			5	0.5	0.3	12		See desc column
D	5905-221-5840		RESISTOR, FIXED, COMPOSITION: 560,000 ohm \pm 10%; 1/2 w; MIL type RC20GF564K			1	0.2	0.1	4		R624
	5905-221-5848		RESISTOR, FIXED, COMPOSITION: 820,000 ohm \pm 10%; 1/2 w; MIL type RC20GF824K			1	0.2	0.1	4		R542
	5905-192-3982		RESISTOR, FIXED, COMPOSITION: 1 meg \pm 10%; 1/2 w; MIL type RC20GF105K (Item Nos: R516, R543, R551, R601, R610, R627)			6	0.6	0.3	14		See desc column
	5905-239-0583		RESISTOR, FIXED, COMPOSITION: 1.2 meg \pm 10%; 1/2 w; MIL type RC20GF125K			1	0.2	0.1	4		R558
	5905-284-3535		RESISTOR, FIXED, COMPOSITION: 4.7 meg \pm 10%; 1/2 w; MIL type RC20GF475K			1	0.2	0.1	4		R706
	5905-283-8550		RESISTOR, FIXED, FILM: 2.7 ohm \pm 5%; 1/2 w; Concarbon NF-1/2 (Item Nos: R507, R514, R524, R529, R534)			5	0.8	0.4	20		See desc column
	5905-257-8217		RESISTOR, FIXED, FILM: 4.7 ohm \pm 5%; 1/2 w; Concarbon NF 1/2 (Item Nos: R289, R515, R525, R530, R535)			4	0.7	0.4	17		See desc column
	5905-577-0643		RESISTOR, FIXED, FILM: 5.1 ohm \pm 5%; 1/2 w; Concarbon NA-15			1	0.2	0.1	6		R289
	5905-279-7059		RESISTOR, FIXED, FILM: 5.6 ohm \pm 5%; 1/2 w; Concarbon NF-1/2			1	0.2	0.1	6		R508

SOURCE CODE	FEDERAL STOCK NUMBER	DESIGNATION BY MODEL	DESCRIPTION	UNIT OF ISSUE	EXP	QTY IN UNIT	DIRECT SUPPORT	GENERAL SUPPORT	DEPOT	ILLUSTRATION	
										FIGURE NO	ITEM NO.
A			R-389 URR (continued)								
F	5905-542-7554		RESISTOR, FIXED, FILM: 182 ohm ± 1%; 1/2 w; MIL type RN20X182F (Item Nos: R116, R117, R121, R122)			4	0.7	0.4	17		See desc column
F	5905-542-9383		RESISTOR, FIXED, FILM: 200 ohm ± 1%; 1/2 w; MIL type RN70B200F (Item Nos: R106, R107, R109, R110)			4	0.7	0.4	17		See desc column
F	5905-284-2233		RESISTOR, FIXED, FILM: 250 ohm ± 1%; 1/2 w; Walker type CPSE-1/2			1	0.2	0.1	6		R108
F	5905-279-7134		RESISTOR, FIXED, FILM: 788 ohm ± 1%; 1/2 w; Walker type CPSE-1/2			1	0.2	0.1	6		R125
F	5905-257-6502		RESISTOR, FIXED, FILM: 918 ohm ± 1%; 1/2 w; Walker type CPSE-1/2			2	0.4	0.2	10		R118 R120
F	5905-296-7769		RESISTOR, FIXED, FILM: 1,210 ohm ± 1%; 1/2 w; MIL type RN20X1211F			1	0.2	0.1	6		R121
F	5905-539-1578		RESISTOR, FIXED, FILM: 2,030 ohm ± 1%; 1/2 w; Aerovox type CPSE-1/2			2	0.4	0.2	6		R113 R115
F	5905-552-5445		RESISTOR, FIXED, FILM: 2,740 ohm ± 1%; 1/2 w; MIL type RN70B2741F			1	0.2	0.1	6		R114
F	5905-279-8020		RESISTOR, FIXED, FILM: 3,190 ohm ± 1%; 1/2 w; IRC type FCC			2	0.4	0.2	10		R111 R112
F	5905-542-9450		RESISTOR, FIXED, FILM: 3,570 ohm ± 1%; 1/2 w; MIL type RN70B3571F			1	0.2	0.1	6		R123
F	5905-556-5317		RESISTOR, FIXED, FILM: 3,920 ohm ± 1%; 1/2 w; MIL type RN70B3921F			1	0.2	0.1	6		R124

SOURCE CODE	FEDERAL STOCK NUMBER	DESIGNATION BY MODEL	DESCRIPTION	UNIT OF ISSUE	EXP	QTY IN UNIT	DIRECT SUPPORT	GENERAL SUPPORT	DEPOT	ILLUSTRATION	
										FIGURE NO.	ITEM NO.
A			R-389/UHR (continued)								
F	5905-157-5563		RESISTOR, FIXED, WIRE WOUND: 20 ohm ± 5%; 8 w; MIL type RW30G200			1	0.2	0.1	6		R213
F	5905-652-2010		RESISTOR, FIXED, WIRE WOUND: 43 ohm ± 5%; 8 w; MIL type RW30V400			1	0.2	0.1	6		R301
F	5905-279-5646		RESISTOR, FIXED, WIRE WOUND: 18,000 ohm ± 5%; 12 w; WL type M-32			1	0.2	0.1	6		R623
F	5905-201-9060		RESISTOR, VARIABLE: WW; 15 ohm ± 10%; 2 w; Mallory type C			1	0.2	0.1	6		R537
F	5905-646-5993		RESISTOR, VARIABLE: comp; 2500 ohm ± 20%; 2 w; MIL type RV4NAYS252D			2	0.4	0.2	10		R101 R104
F	5905-549-8172		RESISTOR, VARIABLE: Comp; 5000 ohm ± 20%; 2 w; AB type 41509			1	0.2	0.1	6		R105
F	5905-192-4351		RESISTOR, VARIABLE: 10,000 ohm ± 20%; 2 w; AB type JL1032-SD-4040L			1	0.2	0.1	6		R260
F	5905-644-5361		RESISTOR, VARIABLE: Comp; 25,000 ohm ± 20%; 1 w; CTS type 90			1	0.2	0.1	6		R562
F	5905-284-3200		RESISTOR, VARIABLE: Comp; 500,000 ohm ± 20%; 2 w; AB part JS2-U5042-F33058			1	0.2	0.1	6		R102
F	5905-257-9473		RESISTOR, VARIABLE: Comp; 500,000 ohm ± 20%; 2 w; CTS part SL870			1	0.2	0.1	6		R614
F	5820-395-9148		ROLLER, CLUTCH: clutch arm control; Collins part/dws 506 6784 002			1	0.2	0.1	4		

SOURCE CODE	FEDERAL STOCK NUMBER	DESIGNATION BY MODEL	DESCRIPTION	UNIT OF ISSUE	QTY IN UNIT	DIRECT SUPPORT	GENERAL SUPPORT	DEPOT	ILLUSTRATION	
									FIGURE NO.	ITEM NO.
A			R389/URR (continued)							
O	5960-272-9094		SHIELD, ELECTRON TUBE: JAN type TS102U02 (Item Nos: E202, E203, E205 thru E213, E501 thru E506, E508, E509, E603, E604, E607, E608, E609, E701, E702)	26	1.7	1.0	42		See desc column	
O	5060-264-3004		SHIELD, ELECTRON TUBE: JAN type TS103U02 (Item Nos: E204, E507, E510, E511, E601, E602)	6	0.6	0.3	14		See desc column	
O	5960-284-4532		SHIELD, ELECTRON TUBE: JAN type TS103U03	1	0.2	0.1	4		E512	
F	5935-256-8693		SOCKET, CRYSTAL: 2 cont; spec MIL-S-12883 MS-35094	2	0.2	0.1	6		XY201 XY501	
F	5935-260-0517		SOCKET, ELECTRON TUBE: JAN type TS101P01	2	0.2	0.1	6		XV605 XV606	
F	5935-260-0516		SOCKET, ELECTRON TUBE: JAN type TS102P01 (Item Nos: XV202, XV203, XV205 thru XV213, XV501 thru XV506, XV508, XV509, XV701, XV702, XV603, XV604, XV607, XV608, XV609)	26	1.7	1.0	42		See desc column	
F	5935-160-1365		SOCKET, ELECTRON TUBE: JAN type TS103P01 (Item Nos: XV204, XV507, XV510, XV511, XV512, XV601, XV602)	7	0.6	0.4	15		See desc column	
F	5820-550-4963		SPRING, HELICAL, EXTENSION: 16 turns; cylindrical shape; Collins part/dwg 340 2090 00	1	0.2	0.1	4			
F	5820-550-4964		SPRING, HELICAL, EXTENSION: for tuning rack; 54 1/2 turns; Collins part/dwg 506 7586 002	8	0.7	0.4	17			
F	5915-503-2262		SUPPRESSOR, PARASTATIC: Resistor and Coil type; Collins part/dwg 240 0095 00	3	0.6	0.3	14		E214 E215 E216	
F	5930-503-3585		SWITCH, ROTARY: AH and H type 81715 WF	1	0.2	0.1	6		S109	
F	5930-546-6730		SWITCH, ROTARY: Oak type N	1	0.2	0.1	6		S102	

SOURCE CODE	FEDERAL STOCK NUMBER	DESIGNATION BY MODEL	DESCRIPTION	UNIT OF ISSUE	EXP	QTY IN UNIT	DIRECT SUPPORT	GENERAL SUPPORT	DEPOT	ILLUSTRATION	
										FIGURE NO.	ITEM NO.
A			R-389/URR (continued)								
F	5930-548-8243		SWITCH, ROTARY: SP, 12 throw; Collins part/dwg 259 0513 00			1	0.2	0.1	6		S104
F	5930-548-8570		SWITCH, ROTARY: SP 12 throw; Collins part/dwg 259 0517 00			1	0.2	0.1	6		S108
F	5930-548-6068		SWITCH, ROTARY: DP 3 throw; Collins part/dwg 259 0514 00			1	0.2	0.1	6		S106
F	5930-548-9471		SWITCH, ROTARY: DP 4 throw; Collins part/dwg 259 0512 00			1	0.2	0.1	6		S101
F	5930-524-0124		SWITCH, ROTARY: 3P 5 throw; Grisby Allison part 6773-4MLW-1-AC			1	0.2	0.1	6		S107
F	5930-548-8572		SWITCH, ROTARY: 4PDT; Collins part/dwg 259 0516 00			1	0.2	0.1	6		S105
F	5930-296-6475		SWITCH, THERMOSTATIC: SPST; Collins part/dwg 292 0035 00			1	0.2	0.1	6		S701
F	5930-636-4623		SWITCH SECTION, ROTARY: DP 5 throw; Collins part/dwg 269 1587 00			3	0.3	0.2	8		S203 A,B,C
F	5930-548-6962		SWITCH SECTION, ROTARY: DP 8 throw; Collins part/dwg 269 0627 00			1	0.2	0.1	6		S204
F	5930-548-9455		SWITCH SECTION, ROTARY: Collins part/dwg 269 1497 00			1	0.2	0.1	6		S504
F	5930-503-4704		SWITCH SECTION, ROTARY: Collins part/dwg 269 1498 00 (Item Nos: S501, S502, S503, S505, S506, S507)			6	0.9	0.6	23		See desc column
F	5930-568-5874		SWITCH SECTION, ROTARY: SP 7 throw; Collins part/dwg 269 1588 00 (Item Nos: S201A thru S201H, S201J)			9	0.8	0.5	19		See desc column
F	5930-568-5873		SWITCH SECTION, ROTARY: SP 12 throw; Collins part/dwg 269 1591 00			1	0.2	0.1	6		S201L

SOURCE CODE	FEDERAL STOCK NUMBER	DESIGNATION BY MODEL	DESCRIPTION	UNIT OF ISSUE	EXP	QTY IN UNIT	DIRECT SUPPORT	GENERAL SUPPORT	DEPOT	ILLUSTRATION	
										FIGURE NO.	ITEM NO.
A			R-339/URR (continued)								
F	5930-548-9450		SWITCH SECTION, ROTARY: SP 12 throw; Collins part/dwg 269 1589 00			1	0.2	0.1	6		S201K
F	5950-567-2579		TRANSFORMER, AUDIO FREQUENCY: p/coupling type; pri 10,000 ohm, secd 600 ohm ct; Sig dwg SM-C-188399			3	0.6	0.3	14		T601 T602 T603
F	5950-523-8417		TRANSFORMER, INTERMEDIATE FREQUENCY: 10 mc ctr freq; shielded; Electro Assemblies part 16-102			1	0.2	0.1	6		T216
F	5950-648-2398		TRANSFORMER, INTERMEDIATE FREQUENCY: 435 to 505 kc freq range; shielded; Collins part/dwg 278 0107 00			1	0.2	0.1	6		T218
F	5950-645-9057		TRANSFORMER, INTERMEDIATE FREQUENCY: 455 kc ctr freq; interstage; shielded; Collins part/dwg 278 0102 00			1	0.2	0.1	6		T501
F	5950-648-1984		TRANSFORMER, INTERMEDIATE FREQUENCY: 455 kc ctr freq; interstage; shielded; Collins part/dwg 278 0103 00			4	0.4	0.2	10		T502 thru T505
F	5950-648-1975		TRANSFORMER, INTERMEDIATE FREQUENCY: 455 kc peak freq; shielded; Collins part/dwg 278 0099 00			1	0.2	0.1	6		T506
F	5950-647-9191		TRANSFORMER, INTERMEDIATE FREQUENCY: 455 kc peak freq; shielded; Collins part/dwg 278 0100 00			1	0.2	0.1	6		Z501
F	5950-545-7800		TRANSFORMER, INTERMEDIATE FREQUENCY: 455 kc peak freq; shielded; Collins part/dwg 278 0101 00			1	0.2	0.1	6		Z503

SOURCE CODE	FEDERAL STOCK NUMBER	DESIGNATION BY MODEL	DESCRIPTION	UNIT OF ISSUE	EXP	QTY IN UNIT	DIRECT SUPPORT	GENERAL SUPPORT	DEPOT	ILLUSTRATION	
										FIGURE NO.	ITEM NO.
A			R-389/URR (continued)								
B	5950-645-8394		TRANSFORMER, POWER, STEP-DOWN: 115/230 v ac, 48/62 cyc, 1 ph input; 27 v, 600 amp output; Triad Catalog 7388-1A			1	0.2	0.1	6		T401
C	5950-395-9214		TRANSFORMER, RADIOFREQUENCY: 14 to 28 kc freq range; Collins part/dwg 278 0204 00			1	0.2	0.1	6		T201
D	5950-395-9210		TRANSFORMER, RADIOFREQUENCY: 14 to 28 kc freq range; Collins part/dwg 278 0207 00			1	0.2	0.1	6		T208
	5950-393-1433		TRANSFORMER, RADIOFREQUENCY: 26 to 56 kc freq range; Collins part/dwg 278 0211 00			1	0.2	0.1	6		T209
	5950-393-1448		TRANSFORMER, RADIOFREQUENCY: 26 to 56 kc freq range; Collins part/dwg 278 0208 00			1	0.2	0.1	6		T202
	5950-395-9213		TRANSFORMER, RADIOFREQUENCY: 54 to 120 kc freq range; Collins part/dwg 278 0212 00			1	0.2	0.1	6		T203
	5950-395-9216		TRANSFORMER, RADIOFREQUENCY: 54 to 120 kc freq range; Collins part/dwg 278 0215 00			1	0.2	0.1	6		T210
	5950-393-1447		TRANSFORMER, RADIOFREQUENCY: 115 to 245 kc freq range; Collins part/dwg 278 0216 00			1	0.2	0.1	6		T204
	5950-395-9221		TRANSFORMER, RADIOFREQUENCY: 115 to 245 kc freq range; Collins part/dwg 278 0219 00			1	0.2	0.1	6		T211
	5950-508-9690		TRANSFORMER, RADIOFREQUENCY: 240 to 505 kc freq range; Collins part/dwg 278 0223 00			1	0.2	0.1	6		T212
	5950-395-9212		TRANSFORMER, RADIOFREQUENCY: 240 to 505 kc freq range; Collins part/dwg 278 0220 00			1	0.2	0.1	6		T205

SOURCE CODE	FEDERAL STOCK NUMBER	DESIGNATION BY MODEL	DESCRIPTION	UNIT OF EXP ISSUE	QTY IN UNIT	DIRECT SUPPORT	GENERAL SUPPORT	DEPOT	ILLUSTRATION	
									FIGURE NO.	ITEM NO.
A B C D			R-389/UHR (continued)							
F	5950-096-7193		TRANSFORMER, RADIOFREQUENCY: 452 to 458 kc freq range; Collins part/dwg 550 9204 004		1	0.2	0.1	6		Z502
F	5950-395-9211		TRANSFORMER, RADIOFREQUENCY: 495 to 870 kc freq range; Collins part/dwg 278 0224 00		1	0.2	0.1	6		T206
F	5950-395-9219		TRANSFORMER, RADIOFREQUENCY: 495 to 870 kc freq range; Collins part/dwg 278 0227 00		1	0.2	0.1	6		T213
F	5950-393-1434		TRANSFORMER, RADIOFREQUENCY: 860 to 1505 kc freq range; Collins part/dwg 278 0228 00		1	0.2	0.1	6		T207
F	5950-395-9218		TRANSFORMER, RADIOFREQUENCY: 860 to 1505 kc freq range; Collins part/dwg 278 0231 00		1	0.2	0.1	6		T214
F	5950-395-9215		TRANSFORMER, RADIOFREQUENCY: 2 single layer wnd pri 50.66 uh at 5 mc; secd 48.23 uh at 5 mc; Collins part/dwg 278 0116 00		1	0.2	0.1	6		T215
F	5950-395-9217		TRANSFORMER, RADIOFREQUENCY: 2 close wnd; pri 2 uh at 10.455 mc; secd 2 uh at 10.455 mc; Collins part/dwg 278 0115 00		1	0.2	0.1	6		T217
F	5820-393-1452		TUNER, RADIOFREQUENCY: 14 to 28 kc freq range; Collins part/dwg 278 0205 00		1	0.2	0.1	6		Z201
F	5820-393-1462		TUNER, RADIOFREQUENCY: 14 to 28 kc freq range; Collins part/dwg 278 0206 00		1	0.2	0.1	6		Z208
F	5820-393-1453		TUNER, RADIOFREQUENCY: 26 to 56 kc freq range; Collins part/dwg 278 0209 00		1	0.2	0.1	6		Z202

SOURCE CODE	FEDERAL STOCK NUMBER	DESIGNATION BY MODEL	DESCRIPTION	UNIT OF ISSUE	QTY IN UNIT	DIRECT SUPPORT	GENERAL SUPPORT	DEPOT	ILLUSTRATION	
									FIGURE NO.	ITEM NO.
A			R-389/URR (continued)							
B										
C										
D										
F	5820-393-1463		TUNER, RADIOFREQUENCY: 26 to 56 kc freq range; Collins part/dwg 278 0210 00		1	0.2	0.1	6		Z209
P	5820-393-1454		TUNER, RADIOFREQUENCY: 54 to 120 kc freq range; Collins part/dwg 278 0213 00		1	0.2	0.1	6		Z203
P	5820-537-5004		TUNER, RADIOFREQUENCY: 54 to 120 kc freq range; Collins part/dwg 278 0214 00		1	0.2	0.1	6		Z210
F	5820-393-1455		TUNER, RADIOFREQUENCY: 115 to 245 kc freq range; Collins part/dwg 278 0217 00		1	0.2	0.1	6		Z204
F	5820-537-5005		TUNER, RADIOFREQUENCY: 115 to 245 kc freq range; Collins part/dwg 278 0218 00		1	0.2	0.1	6		Z211
P	5820-393-1456		TUNER, RADIOFREQUENCY: 240 to 505 kc freq range; Collins part/dwg 278 0221 00		1	0.2	0.1	6		Z205
F	5820-537-5006		TUNER, RADIOFREQUENCY: 240 to 505 kc freq range; Collins part/dwg 278 0222 00		1	0.2	0.1	6		Z212
P	5820-393-1460		TUNER, RADIOFREQUENCY: 469 to 960 kc freq range; Collins part/dwg 278 0198 00		1	0.2	0.1	6		Z218
P	5820-393-1457		TUNER, RADIOFREQUENCY: 495 to 870 kc freq range; Collins part/dwg 278 0225 00		1	0.2	0.1	6		Z206
F	5820-537-5007		TUNER, RADIOFREQUENCY: 495 to 870 kc freq range; Collins part/dwg 278 0226 00		1	0.2	0.1	6		Z213
P	5820-393-1451		TUNER, RADIOFREQUENCY: 860 to 1505 kc freq range; Collins part/dwg 278 0229 00		1	0.2	0.1	6		Z207

SOURCE CODE	FEDERAL STOCK NUMBER	DESIGNATION BY MODEL	DESCRIPTION	UNIT OF ISSUE	QTY IN UNIT	DIRECT SUPPORT	GENERAL SUPPORT	DEPOT	ILLUSTRATION	
									FIGURE NO.	ITEM NO.
A			R-389/URR (continued)							
F	5820-537-5008		TUNER, RADIOFREQUENCY: 860 to 1505 kc freq range; Collins part/dwg 278 0230 00		1	0.2	0.1	6		2214
F	5820-393-1461		TUNER, RADIOFREQUENCY: 950 to 1960 kc freq range; Collins part/dwg 278 0199 00		1	0.2	0.1	6		2217
F	5820-393-1458		TUNER, RADIOFREQUENCY: 8495 to 9505 kc freq range; Collins part/dwg 278 0202 00		1	0.2	0.1	6		2220
F	5820-537-5002		TUNER, RADIOFREQUENCY: 8495 to 9505 kc freq range; Collins part/dwg 278 0203 00		1	0.2	0.1	6		2216
F	5820-393-1459		TUNER, RADIOFREQUENCY: 9495 to 9986 kc freq range; Collins part/dwg 278 0200 00		1	0.2	0.1	6		2219
F	5820-537-5003		TUNER, RADIOFREQUENCY: 9495 to 9986 kc freq range; Collins part/dwg 278 0201 00		1	0.2	0.1	6		2215

Figure 86 (foldout) (as changed by C 1, 2 Feb. 59). Change the value of R554 from 2,200 to: 470.

Figure 87 (foldout). Make the following changes (as changed by C 1, 2 Feb. 59):

Change reference symbol R533 (from pin 6 of V509) to: R553.

Add the following to the notes:

4. IN RECEIVERS WITH SERIAL NUMBER 100 AND UPWARD, R609 IS NOT USED. THE JUNCTION OF R604 AND R608 IS GROUND-ED AND CAPACITOR C612 (8 UF) IS CON-NECTED IN PARALLEL WITH R608.

Delete note 5 (as added by C 1, 2 Feb. 59) and substitute:

5. IN ALL RECEIVERS, B+ 3/8A FUSE F102 IS NOT CONNECTED BETWEEN P120-5 AND +300 V UNREGULATED.

Figure 88 (foldout) (as changed by C 1, 2 Feb. 59). Make the following changes:

In the upper-left portion of the illustration, change the value of R205 to 5,600.

Change the value of R209 to 3,900.

Change the value of R226 to 3,900.

Change the value of R227 to 6,800.

In the upper-right portion of the illustration, change the value of R264 to: 820. Delete R266.

In the center portion of the illustration, change the value of R291 to 39K.

Add the following notes to the illustration.

NOTES:

1. IN RADIO RECEIVERS WITH SERIAL NUMBER 51 AND UPWARD, R220 HAS A VALUE OF 47K. R221 HAS BEEN DELETED AND THE CONNECTION BETWEEN R220 AND PIN 2 OF Z208 HAS BEEN REMOVED. R220 IS CONNECTED TO PIN 3 OF Z208, AND PIN 2 IS CONNECTED TO PIN 1 OF Z208.
2. IN RADIO RECEIVERS WITH SERIAL NUMBER 51 AND UPWARD, R222 IS 27K, AND R223 IS 12K.
3. IN RADIO RECEIVERS WITH SERIAL NUMBER 51 AND UPWARD, R228 IS 15K, AND

R229 IS DELETED. R228 IS CONNECTED TO PIN 3 OF Z212, AND PIN 2 IS DISCON-NECTED FROM F228 AND CONNECTED TO PIN 1 OF Z212.

Delete note 4 (as added by C 1, 2 Feb. 59) and substitute:

4. IN ALL R-389/URR, THE LEADS CONNECT-ED TO FUSE F102 WERE REMOVED AND CONNECTED TOGETHER. A NEW LEAD IS RUN FROM THE CABLE TO FUSE F102 AND IS LABELED P118-15 PS (96) 52. THE OTHER END OF FUSE F102 IS CONNECTED TO TERMINAL 7 OF TB104. THE CONNEC-TION BETWEEN FUSE F103 AND THE CABLE LABELED P118-15 180V PS (96) 52 IS DELETED. THE B+ 3/8A FUSE IS CALLED THE HV 3/8A FUSE.

In the upper right portion of the illustration, change the value of R554 to 470.

Change the value of C536 to 12 $\mu\mu\text{f}$.

Add the following to the notes:

11. IN RECEIVERS WITH SERIAL NUMBER 100 AND UPWARD, R609 IS NOT USED. THE JUNCTION OF R604 AND R608 IS GROUND-ED. CAPACITOR C612 (8 UF) IS CON-NECTED IN PARALLEL WITH R608.
12. IN RECEIVERS WITH SERIAL NUMBER 25 AND UPWARD, THE VALUE OF R702 IS CHANGED TO 68K.
13. IN RECEIVERS WITH SERIAL NUMBER 427 AND UPWARD, C525 IS CHANGED FROM 2 UFF TO 7 UFF.

Delete note 14 (as added by C 1, 2 Feb. 59) and substitute:

14. IN ALL RECEIVERS, THE GROUND CON-NECTION WAS DELETED FROM TERMI-NAL 6 OF T801, AND TERMINAL 6 IS CON-NECTED TO CONTACT 15 OF J818.

Figure 89 (foldout) (as changed by C 1, 2 Feb. 59). Make the following changes:

In the left-center portion of the illustration, change the value of R205 to 5,600.

Change the value of R209 to 3,900.

Change the value of R226 to 3,900.

Change the value of R227 to 6,800.

In the extreme upper right portion of the illustration, change the value of R264 to 820.

Delete R266.

In the lower center portion of the illustration, change the value of R291 to 39K.

Add the following notes:

NOTES:

1. IN RADIO RECEIVERS WITH SERIAL NUMBER 51 AND UPWARD, R220 HAS A VALUE OF 47K. R221 HAS BEEN DELETED AND THE CONNECTION BETWEEN R220 AND PIN 2 OF Z208 HAS BEEN REMOVED. R220 IS CONNECTED TO PIN 3 OF Z208, AND PIN 2 IS CONNECTED TO PIN 1 OF Z208.
2. IN RADIO RECEIVERS WITH SERIAL NUMBER 51 AND UPWARD, R228 IS 15K, AND R229 IS DELETED. R228 IS CONNECTED TO PIN 3 OF Z212, AND PIN 2 IS DISCONNECTED FROM R228 AND CONNECTED TO PIN 1 OF Z212.
3. IN RADIO RECEIVERS WITH SERIAL NUMBERS 51 AND UPWARD, R222 IS 27K AND R223 IS 12K.

In the upper center portion of the illustration, change the value of R554 to 470.

Change the value of C536 to 12 μ f.

Add the following to the notes:

9. IN RECEIVERS WITH SERIAL NUMBER 100 AND UPWARD, R609 IS NOT USED. THE JUNCTION OF R604 AND R608 IS GROUND-ED. CAPACITOR C612 (8 uf) IS CONNECTED IN PARALLEL WITH R608.
10. IN RECEIVERS WITH SERIAL NUMBER 25 AND UPWARD, THE VALUE OF R702 IS CHANGED TO 68K.
11. IN RECEIVERS WITH SERIAL NUMBER 427 AND UPWARD, C525 IS CHANGED FROM 2 uuf TO uuf.

Figure 90 (foldout). Delete note 5 (as added by C 1, 2 Feb. 59) and substitute:

5. ON ALL RECEIVERS, THE THREE WIRES AT STATION 38 FUSE F102 ARE REMOVED AND CONNECTED TOGETHER. THE WIRE LABELED 96 15-30 AT STATION 33 IS REMOVED. A NEW WIRE IS ADDED BETWEEN THE CABLE AND PIN 1 OF FUSE F102 AT STATION 38 LABELED 96 15-30. A WIRE IS ADDED BETWEEN PIN 2 OF FUSE F102 AT STATION 38 AND CONTACT 7 OF TB104 AT STATION 40.

By Order of the Secretary of the Army:

HAROLD K. JOHNSON,
General, United States Army,
Chief of Staff.

Official:

J. C. LAMBERT,
Major General, United States Army,
The Adjutant General.

Distribution:

Active Army:

USASA (2)	USAC (3)	TOAD (14)
CNGB (1)	11th Air Aslt Div (3)	FTWOAD (10)
CC-E (7)	318th USASA Bn (5)	LEAD (7)
Dir of Trans (1)	319th USASA Bn (5)	SHAD (3)
C of Engrs (1)	320th USASA Bn (5)	NAAD (5)
TSG (1)	177th USASA Co (5)	SVAD (5)
CofSptS (1)	182d USASA Co (5)	CHAD (3)
USACDCEA (1)	183rd USASA Co (5)	ATAD (10)
USACDCCBRA (1)	184th USASA Co (5)	LBAD (14)
USACDCCEA (1)	4th USASA Fld Sta (5)	GENDEP (OS) (2)
USACDCOA (1)	9th USASA Fld Sta (5)	Sig Sec, GENDEP (OS) (5)
USACDCQMA (1)	12th USASA Fld Sta (5)	Sig Dep (OS) (12)
USACDCTA (1)	14th USASA Fld Sta (5)	Sig Fld Maint Shops (2)
USACDCADA (1)	15th USASA Fld Sta (5)	AMS (1)
USACDCARMA (1)	Svc Colleges (2)	USAERDAA (2)
USACDCAVNA (1)	Br Svc Sch (2)	USAERDAW (13)
USACDCARTYA (1)	USATC AD (2)	Units org under fol TOE:
USACDCSWA (1)	USATC Armor (2)	11-16 (2)
USACDCCEA, Ft Huachuca (1)	USATC Engr (2)	11-57 (2)
USACDCEC (10)	USATC Inf (2)	11-97 (2)
USAMC (5)	USASTC (2)	11-98 (2)
USCONARC (5)	WRAMC (1)	11-117 (2)
ARADCOM (5)	Army Pic Cen (2)	11-155 (2)
ARADCOM Rgn (2)	Instl (2) except	11-157 (2)
OS Maj Comd (4)	Fort Monmouth (70)	11-337 (2)
LOGCOMD (2)	Fort Hancock (4)	11-500 AA-AE (4)
USAMICOM (4)	Fort Gordon (10)	11-587 (2)
USASMC (2)	Fort Huachuca (10)	11-592 (2)
USASCC (4)	WSMR (5)	11-597 (2)
MDW (1)	Fort Devens (5)	32-67 (2)
Armies (2) except	Fort Carson (25)	32-500 (2)
Seventh USA (5)	Fort Knox (12)	
Corps (2)	Army Dep (2) except	
	SAAD (30)	

NG: None

USAR: None.

For explanation of abbreviations used, see AR 320-50.

CHANGE }
NO. 5 }

HEADQUARTERS
DEPARTMENTS OF THE ARMY
AND THE AIR FORCE
WASHINGTON, DC, 23 August 1976

**RADIO RECEIVER R-389/URR
INCLUDING
REPAIR PARTS AND SPECIAL TOOL LISTS**

TM 11-855/TO 31R1-2URR-161, 2 August 1955, is changed as follows:

Page 1. Make the following changes.

CHAPTER 7 is deleted in its entirety.

The following appendixes are added:

- APPENDIX
- I. REFERENCES
 - II. DELETED
 - III. MAINTENANCE ALLOCATION
 - IV. ORGANIZATIONAL, DIRECT AND GENERAL SUPPORT, AND DEPOT REPAIR PARTS AND SPECIAL TOOL LISTS

Page 2. Paragraph 1.1 is superseded as follows:

1.1. Indexes of Publications

a. *DA Pam 310-4.* Refer to the latest issue of DA Pam 310-4 to determine whether there are new editions, changes, or additional publications pertaining to the equipment.

b. *DA Pam 310-7.* Refer to DA Pam 310-7 to determine whether there are modification work orders (MWO's) pertaining to the equipment.

Paragraph 2 is superseded as follows:

2. Forms and Records

a. *Reports of Maintenance and Unsatisfactory Equipment.* Maintenance forms, records, and reports which are to be used by maintenance personnel at all maintenance levels are listed in and

prescribed by TM 38-750 (Army). Air Force personnel will use AFM 66-1 for maintenance reporting and TO-00-35D54 for unsatisfactory equipment reporting.

b. *Report of Packaging and Handling Deficiencies.* Fill out and forward DD Form 6 (Packaging Improvement Report) as prescribed in AR 700-58/NAVSUPINST 4030.29/AFR 71-13/MCO P4030.29A, and DSAR 4145.8.

c. *Discrepancy in Shipment Report (DISREP) (SF 361).* Fill out and forward Discrepancy in Shipment Report (DISREP) (SF 361) as prescribed in AR 55-38/NAVSUPINST 4610.33A/AFR 75-18/MCO P4610.19B, and DSAR 4500.15.

Paragraphs 2.1 and 2.2 are added after paragraph 2.

2.1. Reporting of Errors

The reporting of errors, omissions, and recommendations for improving this publication by the individual user is encouraged. Reports should be submitted on DA Form 2028, (Recommended Changes to Publications and Blank Forms), and forwarded direct to Commander, US Army Electronics Command, ATTN: DRSEL-MA-Q, Fort Monmouth, NJ 07703.

2.2. Administrative Storage

Administrative storage of equipment issued to and used by Army activities shall be in accordance with TM 740-90-1.

Page 5. Paragraph 7 is superseded by as follows:

7. Items Comprising an Operable Radio Receiver R-389/URR

NSN	Item	Quantity	Dimensions (in.)		Weight (lb)
			Height	Depth	
5820-00-503-1417	Radio Receiver R-389/URR	1	10-1/2	17-1/4	82
	Cable Assembly, Power Electrical CX-1358/U.	1	--	--	2/3
	Cable Assembly, Radio Frequency: 5068142002; 81349	1	--	--	--
	Cable Assembly, Radio Frequency: 5068140002	2	--	--	--

*This change supersedes TM 11-855, C 4, 16 October 1973.

NSN	Item	Quantity	Dimensions (in.)			Weight (lb)
			Height	Depth	Width	
	Crystal Unit, Quartz CR-18/U: 10,455 kHz, MIL-C-3098, 81349	1	--	--	--	--
5955-00-250-0568	Crystal Unit, Quartz CR-45/U: MIL-C-3098, 81349	1	--	--	--	--
5820-00-539-9006	Power Supply PP-621/URR	1	--	--	--	--

Page 6. Paragraph 7.1 is deleted.

Page 124. Paragraphs 130 through 133 are superseded as follows:

130. Test Equipment and Additional Equipment Required

a. The test equipment required for final testing of Radio Receiver R-389/URR is listed below.

- (1) Electronic Multimeter TS-505/U.
- (2) Spectrum Analyzer TS-723/U.
- (3) RF Signal Generator AN/URM-25D.
- (4) Audio Oscillator TS-382A/U.
- (5) Voltmeter, Electronic ME-30A/U.
- (6) Frequency Counter AN/USM-26.
- (7) Multimeter TS-352B/U.

b. The following additional equipment is needed for final testing.

- (1) Resistor, fixed, composition, 33 ohms, 1/2W, ± 5 percent.
- (2) Resistor, fixed, composition, 68 ohms, 1/2W, ± 5 percent.
- (3) Resistor, fixed, composition, 62 ohms, 1/2W, ± 5 percent.
- (4) Resistor, fixed, composition, 60 ohms, 1/2W, ± 5 percent.
- (5) Resistor, fixed, composition, 600 ohms, 1W, ± 5 percent.
- (6) Headset, 600 ohms.

131. Preliminary Requirements and Checks

a. *General Test Conditions:* All tests shall be conducted under the following conditions:

- (1) Ac supply voltage shall be 115 volts, 50-60 cps.
- (2) Allow the equipment to warm up for 30 minutes.
- (3) Ground the R-389/URR during all test operations.
- (4) Connect a 1-watt, 600-ohm composition resistor across terminals 6 and 7 at LOCAL AUDIO (fig. 8).
- (5) The AN/URM-25D rf test signal shall be modulated at 400 cps with 30 percent modulation (set AN/URM-25D MOD SELECTOR switch to 400).
- (6) Balanced dummy antenna shall be constructed as shown on figure 82.

(7) A reading of 0.77 volt ac will be the standard noise output.

(8) A reading of 2.45 volts ac (10 milliwatts) will be the standard audio output.

b. *Standard Control, Switch, and Dial Settings.* The standard control, switch, and dial settings shall be as given in table 1.

Table 1. Control, Switch and Dial Settings

Control or switch	Position
LINE METER	OFF
LINE GAIN	0
AGC	MED
LIMITER	OFF
AUDIO RESPONSE	WIDE
IF BANDWIDTH	As needed
BFO PITCH	0
BREAK IN	OFF
FUNCTION	AGC
BFO	OFF
DIAL LOCK	UNLOCKED
LOCAL GAIN	As needed
RF GAIN	Maximum
OVEN	OFF

c. *Preliminary Checks.* Before testing the R389/URR, perform the following preliminary checks:

- (1) Check to see that all controls are operative and that they do not bind.
- (2) Measure B+ with an electronic multimeter (such as TS-505/U) with the positive lead connected to B+ 180VDC jack J601 (fig. 81) and the negative lead connected to terminal 9, GND connector (fig. 7) of terminal board TB 103. The meter should indicate 180 volts dc ± 5 volts.
- (3) Check to see that all tubes and dial lights are lighted.
- (4) Check the antenna relay (para 106o).

d. *Test Setup.* Connect the test equipment and Radio Receiver R-389/URR as shown in figure 83.

132. Am. Sensitivity Test

The am. sensitivity shall be measured at three frequencies (near each end and center) of each band.

a. Set controls and switches as given in table 1 except for the following:

- (1) FUNCTION switch to MGC.
- (2) AUDIO RESPONSE switch to MEDIUM.
- (3) IF BANDWIDTH switch to 8 KC.

b. Tune the AN/URM-25D to the R-389/URR frequency.

NOTE

The AN/URM-25D is tuned to the same frequency as the R-389/URR when Multimeter TS-505/U measures maximum voltage between connector 16 and GND TB103 (fig. 7) (diode load voltage is maximum at resonant frequency).

c. Adjust the AN/URM-25D attenuator for signal level listed in table 2.

d. Adjust the R-389/URR LOCAL GAIN control for a reading of 2.45 volts ac on the ME-30A/U.

e. Turn the AN/URM-25D MOD SELECTOR switch to OFF. The reading shall be no more than 0.77 volt ac.

Table 2. Signal Level for Am. Sensitivity Test

Band	AN/URM-25D output
15 to 500 kc	6.0 microvolts
500 to 1500 kc	6.0 microvolts

133. Cw Sensitivity Test

The cw sensitivity shall be measured at three frequencies (near each end and center) of each band.

a. Set the R-389/URR switches and controls as given in table 1, except for the following:

- (1) BFO switch to ON.
- (2) FUNCTION switch to ON.
- (3) AUDIO RESPONSE switch to MEDIUM.

b. Tune the AN/URM-25D to the R-389/URR frequency (maximum diode load voltage read on TS-505/U) with the input specified in table 3.

c. Adjust BFO PITCH control for approximately 1,000 cps audio tone output.

d. Adjust the LOCAL GAIN control for a reading of 2.45 volts ac on the ME-30A/U.

e. Turn the BFO PITCH control to OFF.

f. The reading on the ME-30A/U shall not be more than 0.77 volts ac.

Table 3. Signal Level for Cw sensitivity Test

Band	AN/URM-25D output
15 to 500 kc	2.0 microvolts
500 to 1500 kc	2.0 microvolts

Page 128. Chapter 7 is rescinded and new paragraphs 134 through 142 are added after paragraph 133.

134. If. Selectivity Bandwidth Test

a. Set the switches and controls as given in table 1, except for the following:

- (1) FUNCTION switch to MGC.
- (2) IF BANDWIDTH switch to 0.1 KC.
- (3) RF GAIN switch to 5.

b. Set the R389/URR frequency to 400 kc.

c. Set the AN/URM-25D output to 10 microvolts.

d. Tune the AN/URM-25D to the R-389/URR frequency (maximum diode load voltage read on TS-505/U).

e. Adjust RF GAIN control for a diode load voltage of -7 volts dc reference as read on the TS-505/U.

f. Increase the output of AN/URM-25D to 20 microvolts.

g. Detune the AN/URM-25D below 400 kc until a reading of -7 volts dc is again read on the TS-505/U.

h. Record the frequency shown on the AN/USM-26.

i. Tune the AN/URM-25D above 400 kc until -7 volts dc is again read on the TS-505/U.

j. Record the frequency shown on the AN/USM-26.

k. The difference between these two recorded frequencies is the bandwidth between the 20 microvolt points.

l. Repeat a through k above with AN/URM-25D outputs of 100 microvolts, 1,000 microvolts, 10,000 microvolts, and 100,000 microvolts.

m. Repeat c through l above for the 1 KC, 2 KC, 4 KC, and 8 KC positions of the IF BANDWIDTH switch. The bandwidths shall meet the values in table 4 below:

Table 4. If Selectivity Bandwidths

IF BANDWIDTH switch	20 microvolts	100 microvolts	1,000 microvolts	10,000 microvolts	100,000 microvolts
0.1 KC	0.1 kc +50%, -0%	Less than 1.0 kc	Less than 2.7 kc	Less than 4.8 kc	Less than 6.8 kc
1.0 KC	1 kc +50%, -0%	Less than 3.0 kc	Less than 4.8 kc	Less than 6.8 kc	Less than 9.2 kc
2.0 KC	2 kc ±15%	Less than 4.0 kc	Less than 6.0 kc	Less than 8.5 kc	Less than 9.2 kc
4.0 KC	4 kc ±15%	Less than 6.0 kc	Less than 8.0 kc	Less than 10.2 kc	Less than 11.0 kc
8.0 KC	Less than 11.5 kc	Less than 14 kc	Less than 18 kc	Less than 23 kc	Less than 26 kc

NOTE

For R-389/URR on Procurement Order 14124-PH-52, and earlier, line 2, column 2,

shall be 1 kc ±15%, and line 3, column 2 shall be 2 kc ±25%.

Pages 126 and 127. Figures 82 and 83 are superseded as follows:

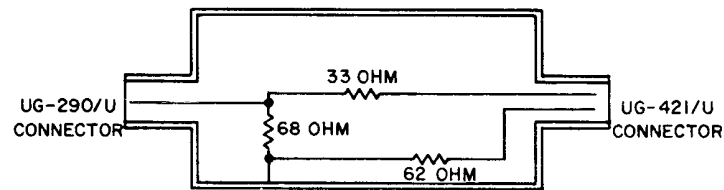

NOTE:
ALL LEADS TO BE SHORT AS POSSIBLE.
ALL RESISTORS TO BE COMPOSITION
1/2 WATT, ± 5%.

EL1FK001

Figure 82. Dummy antenna schematic diagram.

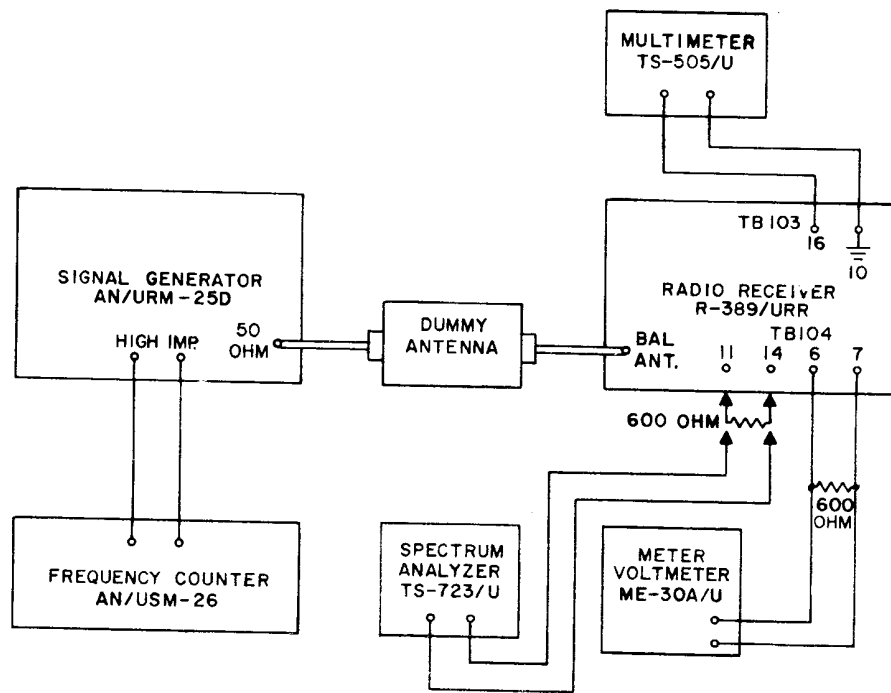

EL1FK002

Figure 83. Equipment hookup diagram for testing Radio Receiver R-389/URR.

135. Maximum Audio Output Test

- a. Set the frequency of the R-389/URR to 1,000 kc.
- b. Set all controls and switches as given in table 1.
- c. Tune the AN/URM-25D to the R-389/GRC frequency with an output of 10 microvolts (maximum diode load voltage on TS-505/U).
- d. Set the AN/URM-25D MOD SELECTOR switch to 400.
- e. Turn the R-389/URR LOCAL GAIN and LINE GAIN controls completely clockwise.
- f. When the audio output is measured at the PHONE and LINE connectors (fig. 7), each must be terminated with a 600-ohm composition resistor.

- g. The output voltages measured at these points with the ME-30A/U shall meet the values table 5.

Table 5. Audio Output Voltages

Audio output terminals	Audio voltage levels
LOCAL AUDIO	Not less than 17.3 volts ac (500 mw across 600 ohms)
LINE AUDIO	Not less than 2.45 volts ac (10 mw across 600 ohms)
PHONE AUDIO	Not less than 1.73 volts ac (5 mw across 600 ohms)

136. Audio Harmonic Distortion Test

- a. This measurement shall be made in conjunction with and under the same test condition as in paragraph 135, except for the following:

(1) Set the AN/URM-25D output at 100 microvolts.

(2) Set R-389/URR AUDIO RESPONSE switch to MEDIUM.

(3) Set IF BANDWIDTH switch to 8 KC.

b. Connect TS-723/U across the LOCAL AUDIO terminals (connectors 6 and 7), terminated with a 600-ohm resistor.

c. The distortion shall not exceed 11 percent.

d. Connect the TS-723/U across the LINE AUDIO terminals (connectors 11 and 14), terminated with a 600-ohm resistor.

e. The distortion shall not exceed 5 percent.

137. Automatic Gain Control Test

a. Set the R-389/URR frequency to 740 kc.

b. Set controls and switches on the R-389/URR as given in table 1.

c. Tune the AN/URM-25D to the R-389/URR frequency and adjust the R-389/URR LOCAL GAIN control for a reading of 2.45 volts on the ME-30A/U.

d. Increase the output of AN/URM-25D to 1,000 microvolts.

e. The reading on ME-30A/U shall not be more than 3.45 volts.

f. Increase the output of the AN/URM-25D to 100,000 MICROVOLTS.

g. The reading on the ME-30A/U shall not be more than 4.5 volts.

138. Dial Calibration Test

a. The switches and controls on the R-389/URR are set as given in table 1, except that the IF BANDWIDTH switch is set to 0.1 KC.

b. Set the R-389/URR dial to the frequencies specified in table 6.

c. Set the AN/URM-25D output to 10 microvolts.

d. Tune the AN/URM-25D to the R-389/URR frequency (maximum voltage measured on the TS-505/U when AN/URM-25D is tuned to the R-389/URR frequency).

e. Read the frequency on the AN/USM-26.

f. The difference between the frequency of the dial setting and the frequency read on the AN/USM-26 shall not be more than the values specified in table 6.

Table 6. Frequency Tolerances

Frequency	Tolerance
15 kc	± 300 cps
30 kc	± 300 cps
60 kc (15 to 500 kc)	± 300 cps
120 kc	± 300 cps
300 kc	± 300 cps
500 kc	± 600 cps

Table 6. Frequency Tolerances — Continued

Frequency	Tolerance
1,000 kc (500 to 1,500 kc)	± 600 cps
1,500 kc	± 600 cps

139. BFO Pitch Control Test

a. All controls and switches on the R-389/URR are set as given in table 1, except the IF BANDWIDTH switch is set to 0.1 KC.

b. Plug the headset into the PHONE jack (fig. 9).

c. Set the output of the AN/URM-25D to 20 microvolts and tune the AN/URM-25D to the R-389/URR frequency (maximum diode load voltage is read on TS-505/U when AN/URM-25D is at R-389/URR frequency).

d. Turn the BFO switch to ON.

e. A zero beat will result in headset if FBO PITCH control is set on 0.

f. Note the frequency shown on the AN/USM-26. Record this frequency as the R-389/URR frequency.

g. Turn the IF BANDWIDTH switch to 8 KC.

h. Rotate the BFO PITCH control to -3. An audio tone will be heard in the headset.

i. Detune the AN/URM-25D for a zero beat. Note the frequency shown on the AN/USM-26.

j. The difference between this frequency and the R-389/URR frequency shall be 3.5 kc ± 0.5 kc.

k. Turn the BFO PITCH control to +3.

l. Detune the AN/URM-25D again to obtain a zero beat note in the headset. Note the frequency on the AN/USM-26.

m. The difference between this frequency and the R389/URR frequency shall be 3.5 kc ± 0.5 kc.

140. Line Level Meter Test

a. Terminate the line terminals, connectors 11 and 14 (fig. 8), with a 600-ohm composition resistor and connect the ME-30A/U across the terminals.

b. Set the R-389/URR frequency dial to 1,000 kc.

c. Set all other controls and switches as in table 1.

d. Set the AN/URM-25D output to 20 microvolts. Tune the AN/URM-25D to the R-389/URR frequency (maximum diode load voltage read on TS-505/U).

e. Turn the R-389/URR LINE METER switch to 0.

f. Adjust R-389/URR LINE GAIN for zero VU reading on LINE LEVEL meter.

g. The reading on the ME-30A/U will be 0.77 volt ± 5 percent.

141. Squelch Threshold Test.

a. Set R-389/URR switches and controls as given in table 1.

b. Place the R-389/URR FUNCTION switch to

TM 11-855, C 5

SQUELCH.

- c. Set the R-389/URR frequency dial to 1,000 kc.
- d. Tune the AN/URM-25D to the R-389/URR frequency.
- e. Set the output of AN/URM-25D to 10 microvolts.
- f. Determine the pull-in and drop-out thresholds by noting the disappearance and presence of audio output as the R-389/URR RF GAIN control is rotated towards minimum and maximum positions.
- g. Rotate RF GAIN control to maximum. This action will ground pin K of J-103 on the rear panel (fig. 7). Verify with an ohmmeter.
- h. Place BREAK IN switch to ON. Pin K of J-103 will now be ungrounded. Verify with an ohmmeter.

142. If. Output Test

- a. Place all controls and switches on the R-389/URR as given in table 1.

- b. Place the R-389/URR FUNCTION switch to MGC.

- c. Terminate IF OUTPUT jack J-104 (fig. 7) with a 60-ohm resistor and connect the ME-30A/U across the resistor.

- d. Set the R-389/URR frequency dial to 1,000 kc.

- e. Tune the AN/URM-25D to the R-389/URR frequency.

- f. Turn the AN/URM-25D output to 3 microvolts.

- g. Adjust the R-389/URR RF GAIN control so that the reading on ME-30A/U will not be less than 20 mv.

- h. Readjust the output of the AN/URM-25D to 30 microvolts.

- i. The reading on ME-30A/U will be 200 microvolts \pm 20 millivolts.

Appendix I is superseded as follows:

APPENDIX I REFERENCES

Following is a list of applicable references available to the organizational repairman of Radio Receiver R-389/URR:

DA Pam 310-4	Index of Technical Manuals, Technical Bulletins, Supply Manuals (Types 7, 8, and 9), Supply Bulletins, and Lubrication Orders.
DA Pam 310-7	US Army Equipment Index of Modification Work Orders.
SB 11-573	Painting and Preservation Supplies Available for Field Use for Electronics Command Equipment.
TB 43-0118	Field Instruction for Painting and Preserving Electronics Command Equipment Including Camouflage Pattern Painting of Electrical Equipment Shelters.
TM 11-6625-255-14	Operator's, Organizational, Direct Support, and General Support Maintenance Manual: Spectrum Analyzer TS-723A/U (NSN 6625-00-833-2602), TS-723B/U (NSN 6625-00-668-9418), TS-723C/U, and TS-723D/U (NSN 6625-00-668-9418).
TM 11-5511	Electronic Multimeter TS-505/U.
TM 11-5551D	R.F. Signal Generator Set AN/URM-25D.
TM 11-5820-359-12P	Operator and Organizational Maintenance Repair Parts and Special Tools List and Maintenance Allocation Chart: Power Supply PP-621/URR.
TM 11-5820-359-35P	Field and Depot Maintenance Repair Parts and Special Tool Lists: Power Supply PP-621/URR.
TM 11-6625-212-15	Operator, Organizational, DS, GS, and Depot Maintenance Manual Including Repair Parts and Special Tool Lists: Frequency Meters AN/USM-26, and AN/USM-26A.
TM 11-6625-261-12	Operator's and Organizational Maintenance Manual: Audio Oscillators TS-382A/U, TS-382B/U, TS-382D/U, TS-382E/U, and TS-382F/U.
TM 11-6625-316-12	Operator and Organizational Maintenance Manual: Test Sets, Electron Tube TV-2/U, TV-2A/U, TV-2B/U, and TV-2C/U.
TM 11-6625-320-12	Operator and Organizational Maintenance Manual: Voltmeter, Meter ME-30A/U, and Voltmeters, Electronic ME-30B/U, ME-30C/U, and ME-30E/U.

TM 11-6625-366-15

Operator's, Organizational, DS, GS, and Depot Maintenance Manual:
Multimeter TS-352B/U.

TM 38-750

The Army Maintenance Management System (TAMMS).

TM 740-90-1

Administrative Storage of Equipment.

Page 129. Figure 84 is rescinded.

Page 130. Figure 85 is superseded as follows:

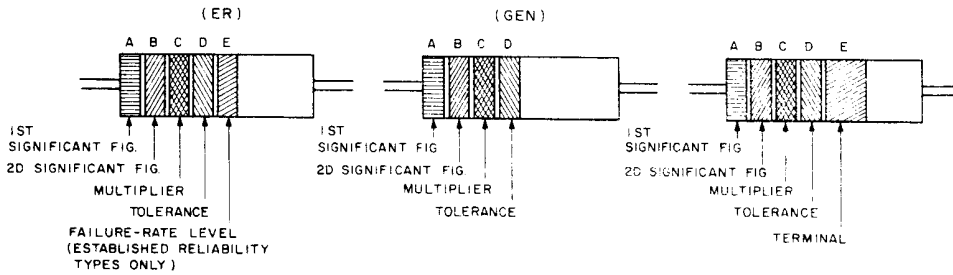

COLOR CODE MARKING FOR COMPOSITION TYPE RESISTORS

COLOR-CODE MARKING FOR FILM-TYPE RESISTORS.

TABLE I
COLOR CODE FOR COMPOSITION TYPE AND FILM TYPE RESISTORS

BAND A		BAND B		BAND C		BAND D		BAND E		
COLOR	FIRST SIGNIFICANT FIGURE	COLOR	SECOND SIGNIFICANT FIGURE	COLOR	MULTIPLIER	COLOR	RESISTANCE TOLERANCE (PERCENT)	COLOR	FAILURE RATE LEVEL	TERM.
BLACK	0	BLACK	0	BLACK	1			BROWN	M=1.0	SOLDERABLE
BROWN	1	BROWN	1	BROWN	10			RED	P=0.1	
RED	2	RED	2	RED	100			ORANGE	R=0.01	
ORANGE	3	ORANGE	3	ORANGE	1,000			YELLOW	S=0.001	
YELLOW	4	YELLOW	4	YELLOW	10,000	SILVER	±10 (COMP. TYPE ONLY)	WHITE		
GREEN	5	GREEN	5	GREEN	100,000	GOLD	±5			
BLUE	6	BLUE	6	BLUE	1,000,000	RED	±2 (NOT APPLICABLE TO ESTABLISHED RELIABILITY)			
PURPLE (VIOLET)	7	PURPLE (VIOLET)	7							
GRAY	8	GRAY	8	SILVER	0.01					
WHITE	9	WHITE	9	GOLD	0.1					

- BAND A — THE FIRST SIGNIFICANT FIGURE OF THE RESISTANCE VALUE (BANDS A THRU D SHALL BE OF EQUAL WIDTH)
- BAND B — THE SECOND SIGNIFICANT FIGURE OF THE RESISTANCE VALUE
- BAND C — THE MULTIPLIER (THE MULTIPLIER IS THE FACTOR BY WHICH THE TWO SIGNIFICANT FIGURES ARE MULTIPLIED TO YIELD THE NOMINAL RESISTANCE VALUE.)
- BAND D — THE RESISTANCE TOLERANCE.
- BAND E — WHEN USED ON COMPOSITION RESISTORS, BAND E INDICATES ESTABLISHED RELIABILITY FAILURE-RATE LEVEL: PERCENT FAILURE PER 1,000 HOURS; ON FILM RESISTORS, THIS BAND SHALL BE APPROXIMATELY 1/12 TIMES THE WIDTH OF OTHER BANDS, AND INDICATES TYPE OF TERMINAL.

RESISTANCES IDENTIFIED BY NUMBERS AND LETTERS (THESE ARE NOT COLOR CODED)

SOME RESISTORS ARE IDENTIFIED BY THREE OR FOUR DIGIT ALPHA NUMERIC DESIGNATORS. THE LETTER P IS USED IN PLACE OF A DECIMAL POINT WHEN FRACTIONAL VALUES OF AN OHM ARE EXPRESSED. FOR EXAMPLE:

2R7 = 2.7 OHMS 10R0 = 10.0 OHMS

FOR WIRE-WOUND-TYPE RESISTORS COLOR CODING IS NOT USED, IDENTIFICATION MARKING IS SPECIFIED IN EACH OF THE APPLICABLE SPECIFICATIONS.

EXAMPLES OF COLOR CODING

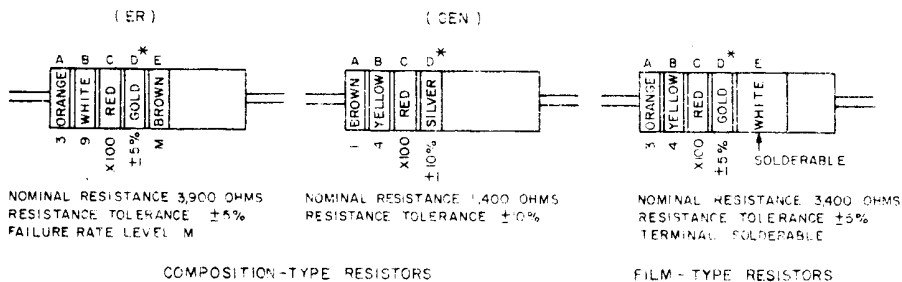

* IF BAND D IS OMITTED, THE RESISTOR TOLERANCE IS ±20% AND THE RESISTOR IS NOT MIL-STD.

A. COLOR CODE MARKING FOR MILITARY STANDARD RESISTORS

U.S. GOVERNMENT PRINTING OFFICE: 1976-665668/760

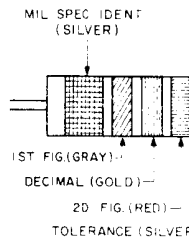

(A) 9.2UH ±1

COLOR CODING FOR TUE OF THE CODING FOR AI A 330UH INDUCTOR A

COLOR COD

COLOR
BLACK
BROWN
RED
ORANGE
YELLOW
GREEN
BLUE
VIOLET
GRAY
WHITE
NONE
SILVER
GOLD

MULTIPLIER ARE MULTIP CHOKE COIL

B. COLOR CODE

CAPACITORS, FIXED, VARIOUS-DIELECTRICS, STYLES CM, CN, CY,

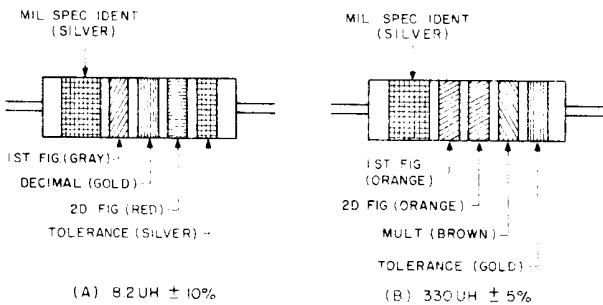
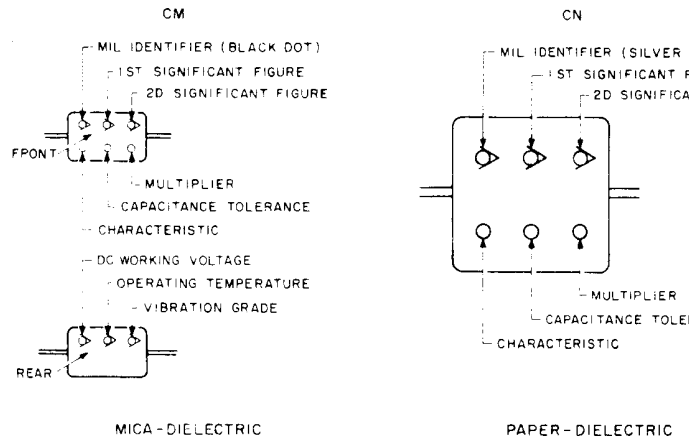

COLOR CODING FOR TUBULAR ENCAPSULATED R.F. CHOKES. AT A, AN EXAMPLE OF THE CODING FOR AN 8.2 uH CHOKE IS GIVEN. AT B, THE COLOR BANDS FOR A 330 uH INDUCTOR ARE ILLUSTRATED.

TABLE 2
 COLOR CODING FOR TUBULAR ENCAPSULATED R.F. CHOKES

COLOR	SIGNIFICANT FIGURE	MULTIPLIER	INDUCTANCE TOLERANCE (PERCENT)
BLACK	0	1	
BROWN	1	10	1
RED	2	100	2
ORANGE	3	1,000	3
YELLOW	4		
GREEN	5		
BLUE	6		
VIOLET	7		
GRAY	8		
WHITE	9		
NONE			20
SILVER			10
GOLD	DECIMAL POINT		5

MULTIPLIER IS THE FACTOR BY WHICH THE TWO COLOR FIGURES ARE MULTIPLIED TO OBTAIN THE INDUCTANCE VALUE OF THE CHOKE COIL.

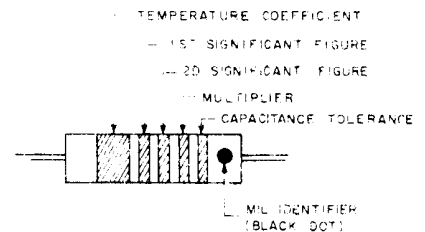

AXIAL LEAD

Figure 85. Resistor, inductor, and capacitor color

B COLOR CODE MARKING FOR MILITARY STANDARD INDUCTORS

DI-ELECTRICS, STYLES CM, CN, CY, AND CB.

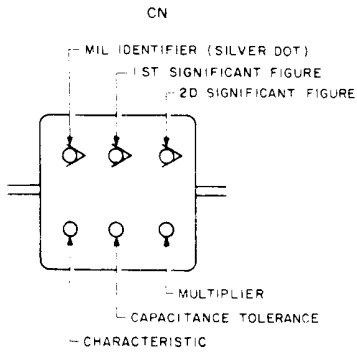

PAPER-DIELECTRIC

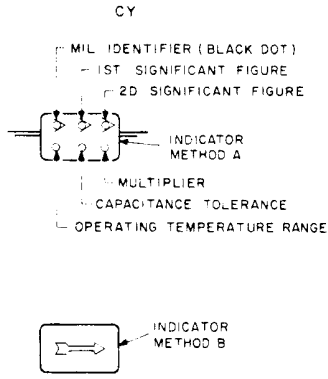

GLASS-DIELECTRIC, GLASS CASE

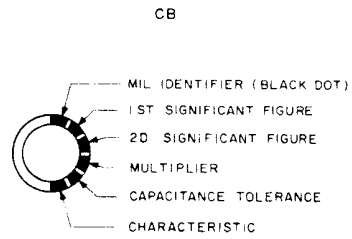

MICA, BUTTON TYPE

TABLE 3 - FOR USE

COLOR	MIL ID	1ST SIG FIG.
BLACK	CM, CY, CB	0
BROWN		1
RED		2
ORANGE		3
YELLOW		4
GREEN		5
BLUE		6
PURPLE (VIOLET)		7
GRAY		8
WHITE		9
GOLD		
SILVER	CN	

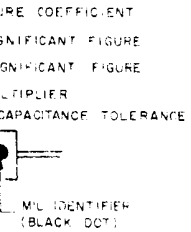

LEAD

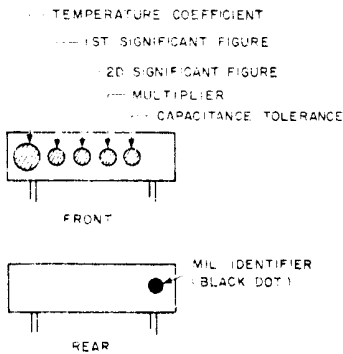

RADIAL LEAD

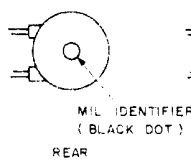

REAR

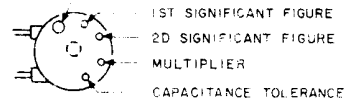

FRONT

DISK-TYPE

TABLE 4 - TEMPE

COLOR	TEMPERATURE COEFFICIENT
BLACK	
BROWN	-1
RED	-1
ORANGE	-1
YELLOW	-2
GREEN	-3
BLUE	-4
PURPLE (VIOLET)	-7
GRAY	
WHITE	
GOLD	+1
SILVER	

- 1 THE MULTIPLIER IS THE CAPACITANCE I
- 2 LETTERS INDICATE MIL-C-250, MIL-C
- 3 LETTERS INDICATE MIL-C-110150
- 4 TEMPERATURE COE

* OPTIONAL CODING

istor, inductor, and capacitor color code charts

C. COLOR CODE MARKING FOR MILITARY STANDARD CAPACITORS

TM 11-855, C 5

TABLE 3 — FOR USE WITH STYLES CM, CN, CY AND CB.

COLOR	MIL ID	1ST SIG FIG.	2D SIG FIG.	MULTIPLIER ¹	CAPACITANCE TOLERANCE				CHARACTERISTIC ²			DC WORKING VOLTAGE	OPERATING TEMP RANGE	VIBRATION GRADE
					CM	CN	CY	CB	CM	CN	CB			
BLACK	CM, CY, CB	0	0	1			±20%	±20%		A			-55° _{T0} +70°C	10-55 HZ
BROWN		1	1	10					B	E	B			
RED		2	2	100	±2%		±2%	±2%	C				-55° _{T0} +85°C	
ORANGE		3	3	1,000		±30%			D		D	300		
YELLOW		4	4	10,000					E				-55° _{T0} +125°C	10-2,000HZ
GREEN		5	5		±5%				F			500		
BLUE		6	6										-55° _{T0} +150°C	
PURPLE (VIOLET)		7	7											
GRAY		8	8											
WHITE		9	9											
GOLD				0.1			±5%	±5%						
SILVER	CN			0.01	±10%	±10%	±10%	±10%						

TABLE 4 — TEMPERATURE COMPENSATING, STYLE CC.

COLOR	TEMPERATURE COEFFICIENT ⁴	1ST SIG FIG.	2D SIG FIG.	MULTIPLIER ¹	CAPACITANCE TOLERANCE		MIL ID
					CAPACITANCES OVER 10 UUF	CAPACITANCES 10 UUF OR LESS	
BLACK	0	0	0	1		± 2.0 UUF	CC
BROWN	-30	1	1	10	± 1%		
RED	-80	2	2	100	± 2%	± 0.25 UUF	
ORANGE	-150	3	3	1,000			
YELLOW	-220	4	4				
GREEN	-330	5	5		± 5%	± 0.5 UUF	
BLUE	-470	6	6				
PURPLE (VIOLET)	-750	7	7				
GRAY		8	8	0.01*			
WHITE		9	9	0.1*	± 10%		
GOLD	+100			0.1		± 1.0 UUF	
SILVER				0.01			

- 1 THE MULTIPLIER IS THE NUMBER BY WHICH THE TWO SIGNIFICANT (SIG) FIGURES ARE MULTIPLIED TO OBTAIN THE CAPACITANCE IN UUF.
 - 2 LETTERS INDICATE THE CHARACTERISTICS DESIGNATED IN APPLICABLE SPECIFICATIONS: MIL-C-5, MIL-C-250, MIL-C-11272B, AND MIL-C-10950C RESPECTIVELY.
 - 3 LETTERS INDICATE THE TEMPERATURE RANGE AND VOLTAGE-TEMPERATURE LIMITS DESIGNATED IN MIL-C-11015D.
 - 4 TEMPERATURE COEFFICIENT IN PARTS PER MILLION PER DEGREE CENTIGRADE.
- * OPTIONAL CODING WHERE METALLIC PIGMENTS ARE UNDESIRABLE.

Appendix II. Appendix II is rescinded.

By Order of the Secretary of the Army:

Official:

PAUL T. SMITH
Major General, United States Army
The Adjutant General

FRED C. WEYAND
General, United States Army
Chief of Staff

DISTRIBUTION:

To be distributed in accordance with DA Form 12-51, operator maintenance requirements for R-389/URR.

CHANGES }
No. 6 }

HEADQUARTERS
DEPARTMENT OF THE ARMY
WASHINGTON, DC, *25 August 1977*

**RADIO RECEIVER R-389/URR (NSN 5820-00-503-1417),
INCLUDING REPAIR PARTS AND SPECIAL TOOLS LISTS**

TM 11-855, 2 August 1955, is changed as follows:

Title of manual is changed as shown above.

Page preceding Table of Contents. Add radiation warning.

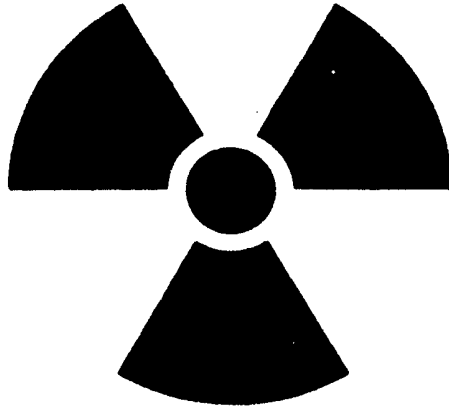

Audio Level Meter	Ra 226	0.60uCi	6625-00-669-0769
	Electron Tube 5651WA		5960-00-262-0286
Raytheon	Kr 85	0.012uCi	
Raytheon	Co 60	0.0125uCi	
Tung-Sol	Ra 226	0.005uCi	
RCA	Ni 63	0.01uCi	
Sylvania	Kr 85	0.013uCi	

Radiation Hazard Information: The following radiation hazard information must be read and understood by all personnel before operating or repairing the Radio Receiver R-389/URR. Hazardous radioactive materials are present in the above listed components of Radio Receiver R-389/URR. The components are potentially hazardous when broken. See qualified medical personnel and the local Radiological Protection Officer (RPO) immediately if you are exposed to or cut by broken components. First aid instructions are contained in TB 43-0122, and AR 755-15.

NEVER place radioactive components in your pocket. Use extreme care NOT to break radioactive components while handling them.

NEVER remove radioactive components from cartons until you are ready to use them.

If any of these components are broken, notify the local RPO immediately. The RPO will survey the immediate area for radiological contamination and will supervise the removal of broken components. The above listed radioactive components *will not* be repaired or disassembled.

Disposal of broken, unserviceable, or unwanted radioactive components will be accomplished in accordance with the instructions in AR 755-15.

By Order of the Secretary of the Army:

BERNARD W. ROGERS
General, United States Army
Chief of Staff

Official:

PAUL T. SMITH
Major General, United States Army
The Adjutant General

Distribution:

To be distributed in accordance with DA Form 12-51, Operator maintenance requirements for R-389/URR.

☆ U.S. GOVERNMENT PRINTING OFFICE: 1977-765010/118

TECHNICAL MANUAL }
 No. 11-855 }
 TECHNICAL ORDER }
 No. 31R1-2URR-161 }

DEPARTMENTS OF THE ARMY AND
 THE AIR FORCE

WASHINGTON 25, D. C., 2 August, 1955

RADIO RECEIVER R-389/URR

	<i>Paragraphs</i>	<i>Page</i>
CHAPTER 1. INTRODUCTION		
Section I. General.....	1, 2	2
II. Description and data.....	3-12	2
CHAPTER 2. INSTALLATION		
Section I. Service upon receipt of Radio Receiver R-389/URR.....	13-18	7
II. Controls and instruments.....	19, 20	14
CHAPTER 3. OPERATION		
Section I. Operation under usual conditions.....	21-28	16
II. Operation under unusual conditions.....	29-32	18
CHAPTER 4. ORGANIZATIONAL MAINTENANCE		
Section I. Tools and equipment.....	33, 34	20
II. Preventive maintenance services.....	35-38	20
III. Lubrication and weatherproofing.....	39-41	22
IV. Troubleshooting at organizational maintenance level.....	42-48	25
CHAPTER 5. THEORY		
Section I. Theory of Radio Receiver R-389/URR.....	49, 50	31
II. Circuit analysis.....	51-86	33
III. Analysis of tuning system.....	87-89	73
CHAPTER 6. FIELD MAINTENANCE		
Section I. Troubleshooting at field maintenance level.....	90-109	83
II. Repairs.....	110-113	105
III. Alinement and adjustment procedures.....	114-128	112
IV. Final testing.....	129-133	124
CHAPTER 7. SHIPMENT AND LIMITED STORAGE AND DEMOLITION TO PREVENT ENEMY USE		
Section I. Shipment and limited storage.....	134, 135	128
II. Demolition of materiel to prevent enemy use.....	136, 137	128
INDEX.....		131

CHAPTER 1

INTRODUCTION

Section I. GENERAL

1. Scope

a. This manual contains information for the installation, operation, maintenance and repair of Radio Receiver R-389/URR (fig. 1).

b. Forward comments on this manual direct to Commanding Officer, the Signal Corps Publications Agency, Fort Monmouth, N. J., ATTN: Standards Division.

2. Forms and Records

The following forms will be used for reporting unsatisfactory conditions of Army equipment and in performing preventive maintenance:

a. DD Form 6, Report of Damaged or Improper Shipment, will be filled out and forwarded as prescribed in SR 745-45-5/Navy Shipping Guide, Article 1850-4/AFR 71-4.

b. DA Form 468, Unsatisfactory Equipment

Report, will be filled out and forwarded to the Office of the Chief Signal Officer, as prescribed in SR 700-45-5.

c. DD Form 535, Unsatisfactory Report, will be filled out and forwarded to Commanding General, Air Materiel Command, Wright-Patterson Air Force Base, Dayton, Ohio, as prescribed in SR 700-45-5 and AF TO 00-35D-54.

d. DA Form 11-238, Operator First Echelon Maintenance Check List for Signal Corps Equipment (Radio Communication, Direction Finding, Carrier, Radar), will be prepared in accordance with instructions on the back of the form (fig. 10).

e. DA Form 11-239, Second and Third Echelon Maintenance Check List for Signal Corps Equipment (Radio Communication, Direction Finding, Carrier, Radar), will be prepared in accordance with instructions on the back of the form (fig. 11).

f. Use other forms and records as authorized.

Section II. DESCRIPTION AND DATA

3. Purpose

Radio Receiver R-389/URR (fig. 1) is a stable, general purpose receiver for use in fixed service. The receiver provides reception of continuous-wave (c-w) and amplitude-modulated (a-m) tone radiotelegraph signals, a-m voice signals, and frequency-shift keyed signals within the frequency range of 15 to 1,500 kilocycles (kc). It is one of a series of receivers, consisting of Radio Receivers R-389/URR, R-390/URR, and R-391/URR. These receivers have a number of features in common, among which are unitized construction and interchangeability of certain subchassis.

4. System Application

Radio Receiver R-389/URR can be used in a radioteletype receiving system (fig. 2). A balanced antenna feeds the incoming frequency-shift signals to the receiver, where the carrier frequency

is converted to a 455 kc intermediate frequency (if.). This if. signal, taken from the receiver, is then fed to Frequency Shift Converter CV-115/URR, producing signals for operation of teletypewriter equipment. The receiver is connected for system operation as described in paragraph 17.

5. Technical Characteristics

Type of circuit.....	Double conversion superheterodyne.
Frequency range.....	15 to 1,500 kc (2 ranges, 7 bands).
Types of signals received---	A1-cw; A2-mew; A3-voice; F1-frequency-shift keying.
Type of tuning.....	Manual or motor tuning, with automatic band switching.
Calibration.....	Direct reading on a counter-type dial.
Calibration error.....	Not more than 300 cps in 15- to 500-kc range; not more than 600 cps in 500- to 1,500-kc range.



Figure 1. Radio Receiver R-389/URR.

Audio Power output:

- 600-ohm unbalanced line 500 mw.
- 600-ohm balanced line 10 mw.
- Phones 5 mw.

If. selectivity 100 cps to 8 kc in 5 steps.

Intermediate frequencies:

- First conversion 10 mc.
- Second conversion 455 kc.

Power source 115/230 volts ac $\pm 10\%$, 48 to 62 cps.

Power input:

- 115/230 volts ac 250 watts total; 150 watts with oven heater off.

Number of tubes 36.

Antenna:

- Unbalanced Random length.
- Balanced 125-ohm terminating impedance.
- Temperature range -40°C to 65°C (-40°F to 149°F).
- Operating altitude Up to 10,000 feet.
- Weight 82 lb.

6. Packaging Data

When packed for shipment, Radio Receiver R-389/URR is placed in moisture-vaporproof container and packed in a wooden crate. A cutaway view of the shipping crate and its contents is shown in figure 3. The package is 21 inches high, 32

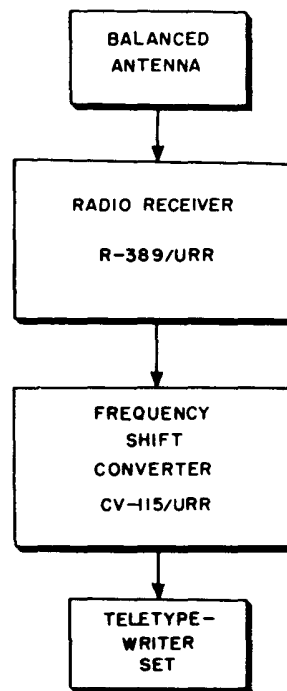
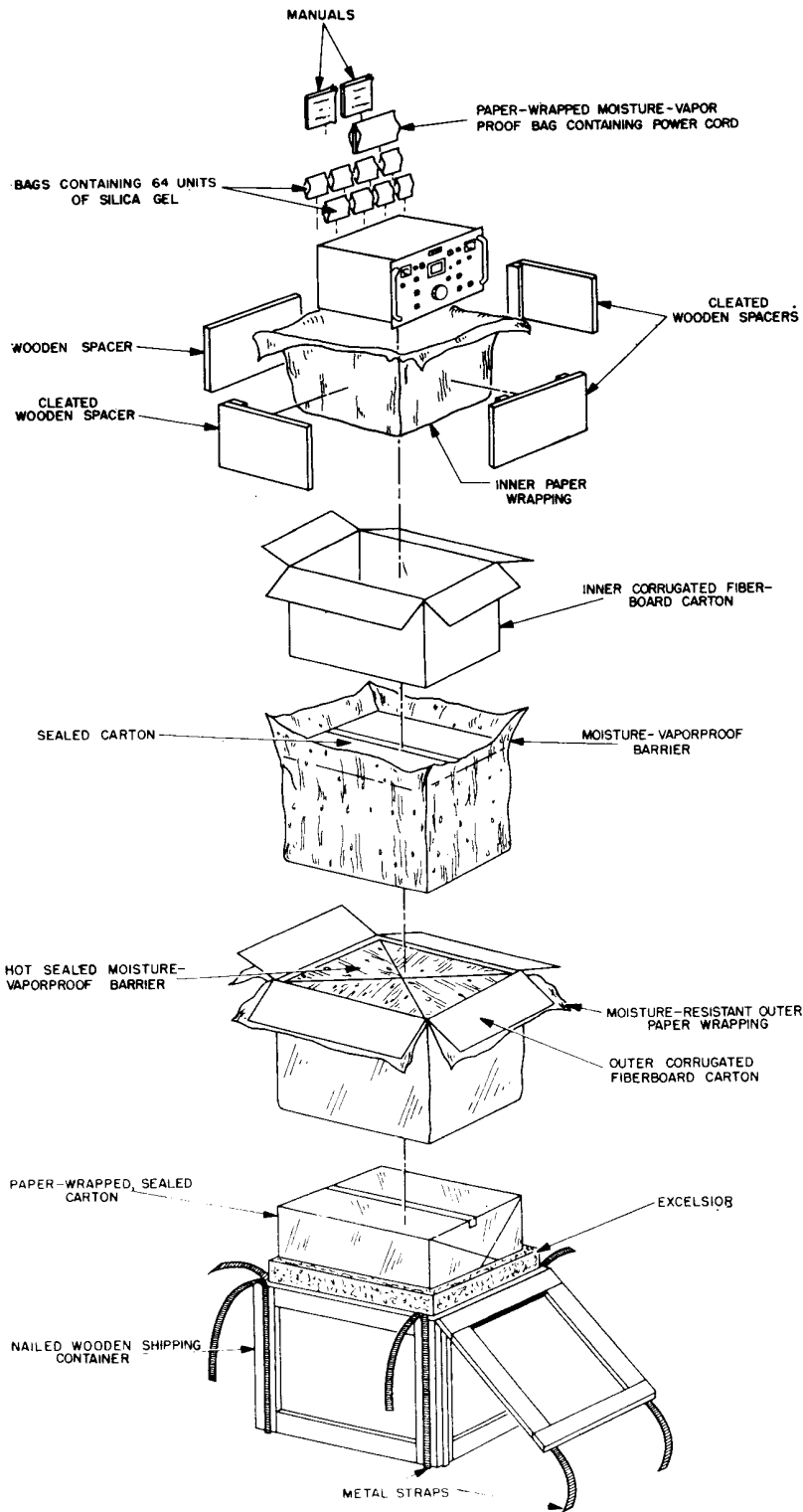

Figure 2. Radioteletype receiving system, block diagram.

TM 655-2



TM 855-3.

Figure 3. Packaging.

inches wide, and 32 inches long; its volume is approximately 12.4 cubic inches. Weight is approximately 115 pounds.

7. Table of Components

Component	Re-quired No.	Height (in.)	Depth (in.)	Width (in.)	Unit weight (lb.)
Radio Receiver R-389/URR	1	10½	17¾	19	82
Power Cable Assembly CX-1358/U	1			96	¾
Manual	2	2	11	8½	1½
Total					85¾

Note. This list is for general information only. See appropriate supply publications for information pertaining to requisition of spare parts.

8. Description of Radio Receiver R-389/URR (fig. 1)

a. The receiver is designed to be mounted in a standard 19-inch equipment rack. The structural parts are made of aluminum. Protective dust covers are provided on the top and bottom of the receiver.

b. All operating controls are located on the front panel, which has a gray, semigloss finish.

(1) The frequency to which the receiver is tuned is indicated on one of two sets of countertype indicators. Two sets of counters are used to coincide with the two ranges into which the frequency range of the receiver is divided. The set of counters not in use is automatically masked, so that only one set is seen by the operator at any time.

(2) Two meters are mounted on the front panel. One meter, marked LINE LEVEL, indicates in volume units (vu) the level of the audio signal being fed over a line to a remote point. The second meter, marked CARRIER LEVEL, indicates the relative strength of incoming signals.

c. The back panel of the receiver (fig. 7) contains special tools, operating and spare fuses, and terminal strips for connections to auxiliary equipment and for test purposes.

d. The unitized construction of the receiver consists of five subchassis held in a main frame

(figs. 70 and 71). Two of the subchassis (if. and radio-frequency (rf)) are in the upper part of the main frame; the remaining three subchassis (power supply, audio frequency (af), and variable-frequency oscillator (vfo)) are mounted in the lower section. The rf subchassis carries the mechanical tuning system. All of the subchassis are interchangeable with those in other Radio Receivers R-389/URR. The power supply, if., and af subchassis can be interchanged with those in Radio Receivers R-390/URR and R-391/URR.

9. Description of Cases and Cabinets Used With Radio Receiver R-389/URR

A case and a rack-type cabinet (not supplied) are available for use with the receiver. The receiver may be mounted in any standard 19-inch rack, provided that adequate ventilation is furnished and that the entire weight of the receiver is not supported by the front panel alone when the receiver is used in mobile service.

a. Cabinet CY-917/URR. This is a lightweight, tabletop cabinet designed for general fixed-station use.

b. Electrical Equipment Cabinet CY-1119/U. The electrical equipment cabinet is a floor-mounted, rack-type installation designed for fixed-station use. Seventy inches of panel space are provided for accommodating several components. One-man installation of equipment is possible through the use of shelf-type angle brackets.

Caution: When Radio Receiver R-389/URR is installed in any case other than those described above, adequate ventilation must be provided. In mobile use, the receiver must be supported in the manner provided in Case CY-979/URR and Electrical Equipment Cabinet CY-1216/U. For mobile applications of the receiver in other cabinets, support must be provided at the rear of the receiver, so that the front panel does not carry the entire weight.

10. Power Supply PP-621/URR (fig. 62)

a. Power Supply PP-621/URR consists of a power transformer, two 26Z5W rectifier tubes, and associated circuits mounted on a removable subchassis. It is mounted in a compartment on the lower deck of the main frame. The alternating-current (ac) power supply furnishes the proper voltage for operation of Radio Receiver R-389/URR from a 115- or 230-volt ± 10 percent, 48- to

62-cycle source. A switch on the subchassis can be locked in the proper position for either 115-volt or 230-volt operation.

b. Power Cable Assembly CX-1358/U (fig. 1) is used to connect the receiver to a 115-volt or 230-volt ac source. It is made up of an 8-foot, two-conductor cable terminated in a screw-locking plug at one end and a standard parallel-prong ac plug at the other end. The screw-locking plug has a center lead screw for securing the cable plug to the POWER receptacle of the receiver.

11. Running Spares

A group of running spares is furnished with each receiver. Spares are provided for all normally expendable items such as tubes, dial lamps, fuses, and motor brushes. The following is a list of running spares:

- 2 regulators, type 3TF7
- 2 tubes, type 6AK6
- 3 tubes, type 6BH6
- 3 tubes, type 6BJ6
- 2 tubes, type 6C4
- 1 tube, type 12AT7
- 1 tube, type 12AU7
- 1 tube, type 26Z5W

- 4 tubes, type 5749/6BA6W
- 2 tubes, type 5750/6BE6W
- 1 tube, type 6082
- 4 dial lamps
- 6 fuses, $\frac{3}{8}$ -ampere, type 3AG
- 6 fuses, 3-ampere, type 3AG
- 2 brushes, motor

12. Additional Equipment Required

The following material is *not* supplied as part of Radio Receiver R-389/URR, but is required for its operation.

- Antenna:
- Balanced..... Balanced doublet; 125-ohm terminating impedance.
 - Unbalanced..... Random length.
- Transmission line:
- Balanced or unbalanced. 70 to 200 ohms.
- Headset..... Headset HS-30 or equivalent (600 ohms).
- Loudspeaker..... 600 ohms.
- Adapter connector:
- UG-970/U..... Adapts Plug PL-259 on unbalanced antenna lead-in to ANTENNA BALANCED 125-ohm connector J106.
 - UG-971/U..... Adapts Plug Connector UG-573/U on unbalanced antenna lead-in to J106.

CHAPTER 2

INSTALLATION

Section I. SERVICE UPON RECEIPT OF RADIO RECEIVER R-389/URR

13. Siting

(fig. 4)

a. General. The best location for radio equipment depends on the tactical situation and local conditions, such as the following: the need to house the equipment where its shelter cannot be seen; the type of housing available; the terrain; and the need of easy access by messengers. Reception with Radio Receiver R-389/URR is best when the antenna is high and clear of hills, build-

ings, cliffs, densely wooded areas, and other obstructions. Depressions, valleys, and other low places are poor locations for radio reception, because the surrounding high terrain absorbs rf energy. Weak or otherwise undesirable signals may be expected if the receiver is operated under or close to steel bridges, underpasses, power lines, hospitals, or power units. Choose, if possible, a location on a hilltop or an elevation. Normally, reception over water is better than over land. See

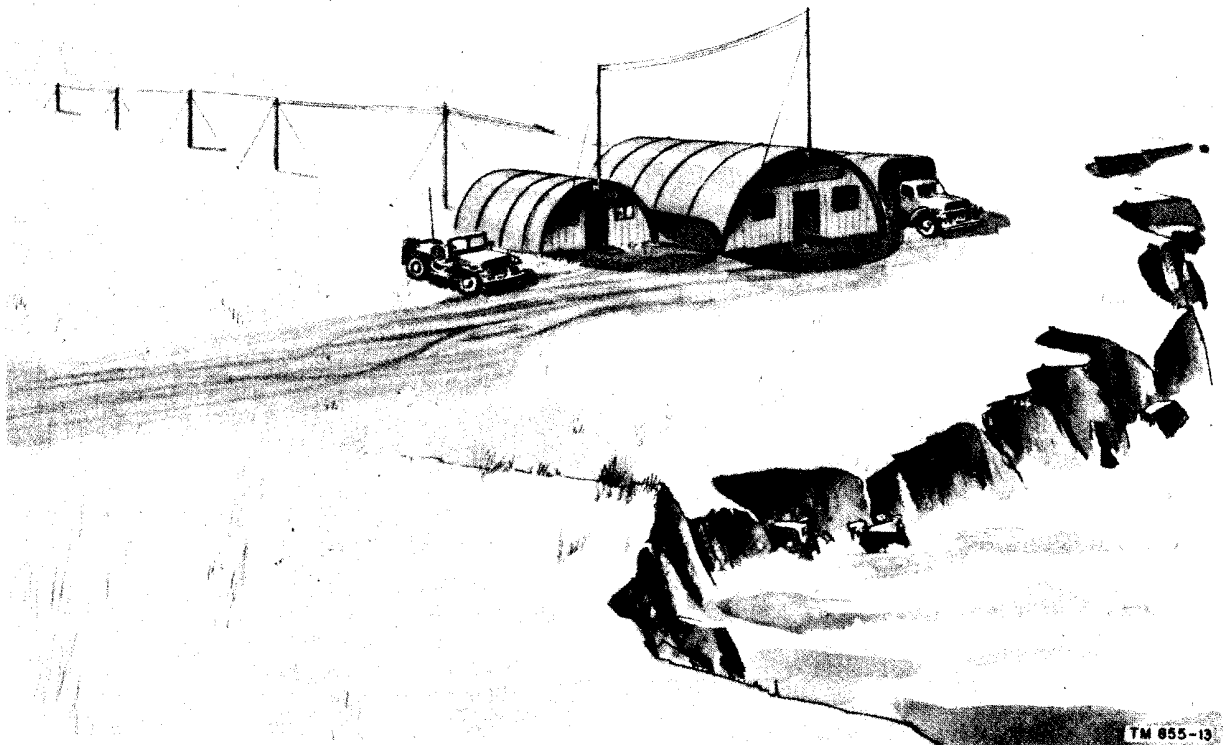

Figure 4. An ideal antenna installation.

that drainage is adequate to prevent flooding the interior of the shelter. If the equipment is part of a communication center but is not to be installed within the center, locate the receiver nearby. If possible, avoid locating the receiver near field hospitals or other sources of radio interference. Figure 4 shows an ideal low-frequency antenna installation.

b. Shelter Requirements. If the receiver is to be installed for fixed service, install it in the shelter as follows:

- (1) Mount the receiver in one of the cases or cabinets described in paragraph 9.
- (2) For tabletop installations, provide a bench or table that can support the weight of the receiver.
- (3) Locate the receiver close to a 115- or 230-volt ac power outlet.
- (4) Provide enough lighting for day or night operation. Set up the receiver so that the operators can see the panel markings clearly. Install lights so that they light up the panel. If possible, provide a portable drop light and an extension cord to help the repairman.

14. Unpacking and Checking New Equipment

Note. For used or reconditioned equipment, refer to paragraph 18.

a. General. When new equipment is received, select a place where it can be unpacked without being exposed to weather conditions and where it can be installed easily.

Caution: Be careful not to damage the receiver when unpacking and handling it. It may become useless or may need a complete overhaul.

b. Unpacking. Perform all the steps below when unpacking new equipment. Refer to figure 3.

- (1) Place the packing case as near as possible to the operating position.
- (2) Cut and fold back the metal straps.
- (3) Remove nails with a nail puller. Remove the top and one side of the wooden shipping crate. Do not attempt to pry off the side and top, because the equipment may become damaged.
- (4) Remove the excelsior that covers the paper-wrapped sealed carton inside the crate, and take out the carton.
- (5) Remove the paper covering from the carton, open the outer corrugated fiber-

board carton, and pull out the inner carton inclosed in the moisture-vaporproof barrier.

- (6) Slit open the seams of the moisture-vaporproof barrier and remove the inner corrugated fiberboard carton.
- (7) Open the inner carton and remove the four wooden spacers.
- (8) Remove the bags of silica gel, the manuals, and the package containing the power cord from the space at the rear of the receiver.
- (9) Withdraw the paper-wrapped receiver from the inner carton, place it on a work bench or near its final location, and remove the paper wrapping.

c. Checking.

- (1) Check the contents of the cartons against the master packing slip.
- (2) Check the front panel of the receiver for damage to knobs or to glass windows of meters and frequency-indicator dials.
- (3) Release the DIAL LOCK and rotate the FREQ CHANGE control knob several turns in each direction; note whether it turns freely and whether the number wheels of the frequency indicator revolve properly.
- (4) Turn the FREQ RANGE switch through each position; note whether it turns freely and whether the frequency-indicator mask operates properly.
- (5) Remove the top and bottom dust covers by removing the 16 screws and lock washers that secure the covers to the main frame.
- (6) The receiver is shipped with all tubes in place. Refer to figures 5 and 6, and check to see that each socket contains the proper tube type. Be sure that all tubes are seated firmly in their sockets and that all tube shields and connectors are tight.

Note. To reach tubes V206 and V209, tune the FREQ CHANGE control to the highest frequency on either range. This will raise the slug rack above the tubes to its greatest height. The shield on tube V701 has a spring clip around it. Lift up on the forward part of the clip to loosen it from the shield. The shield for this tube has an inner sleeve; be sure to use it only on V701. Tubes V605 and V606 are held in their sockets by spring-loaded clamps. To remove these tubes, lift the clamps and turn them far enough to clear the tubes.

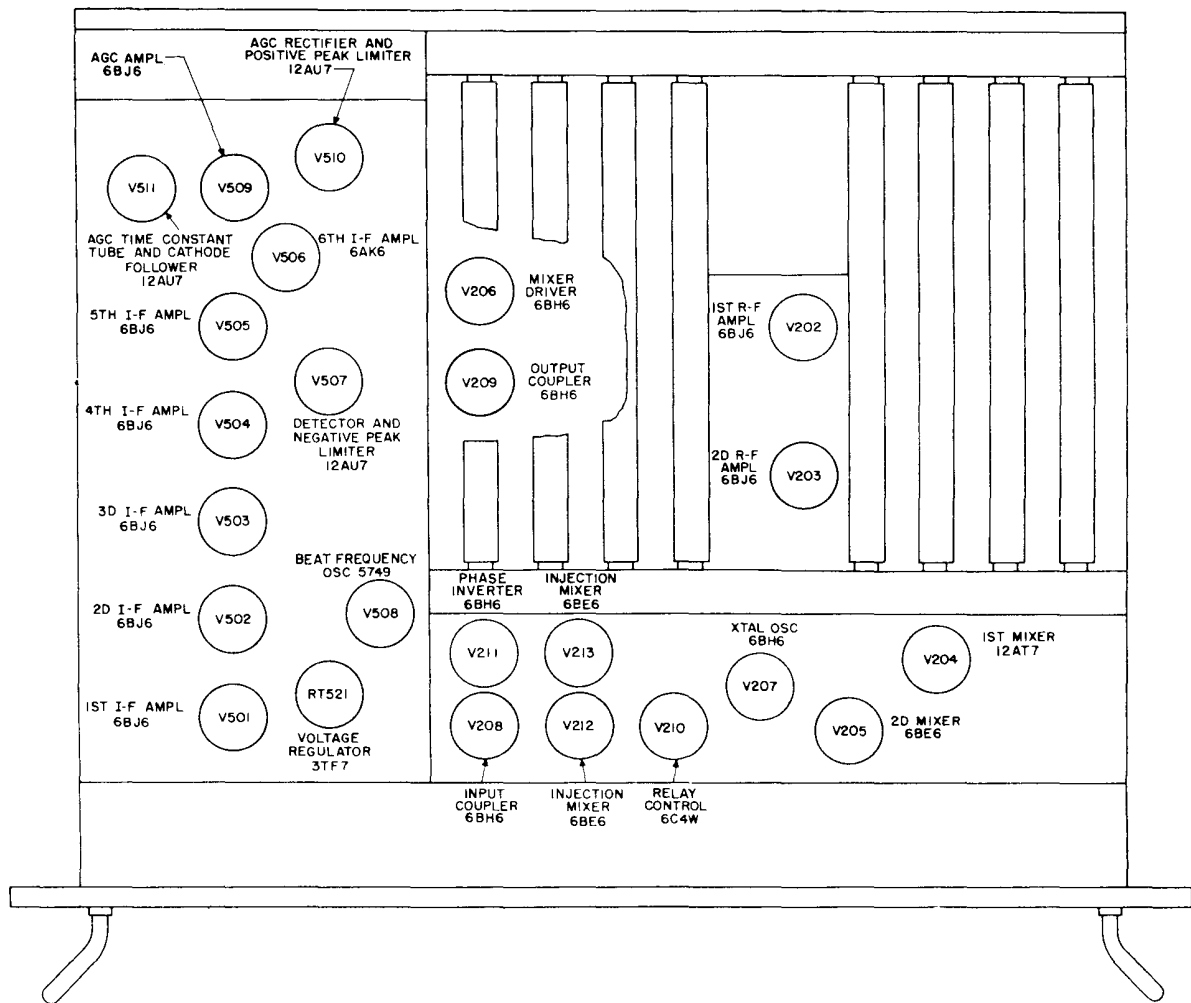

TM855-20

Figure 5. Top deck, tube location.

- (7) Check the voltage of the power source to which the receiver will be connected. Be sure that switch S801, on Power Supply PP-621/URR, is in the proper position for that voltage (115 or 230). The switch can be reached from the bottom of the chassis. See figure 71 for the location of the switch. Replace the dust covers.
- (8) Remove the AC 3A and the B+ 3/8A fuses from their holders in the back panel (fig. 7) and check to see that they are of the proper rating. Be sure that the fuses are seated firmly when replacing them. In this receiver, no fuse is used in the holder marked DC 20A; instead, a bake-lite rod is installed.

Caution: When the receiver is to be operated from a 230-volt source, change the fuse in the holder marked AC 3A (fig. 7) from a 3-ampere, 125-volt type to a 3-ampere, 250-volt type. To avoid damage to Radio Receiver R-389/URR, do not use any fuses other than those specified.

- (9) Inspect for bent or broken connectors and terminals on the rear panel. Check to see that all special tools are in place in their holders (fig. 7). Remove the spare-fuse cover and check to see that the spare fuses of proper ratings are in place.
- (10) Check the contents of the box that contains running spares for damaged parts.

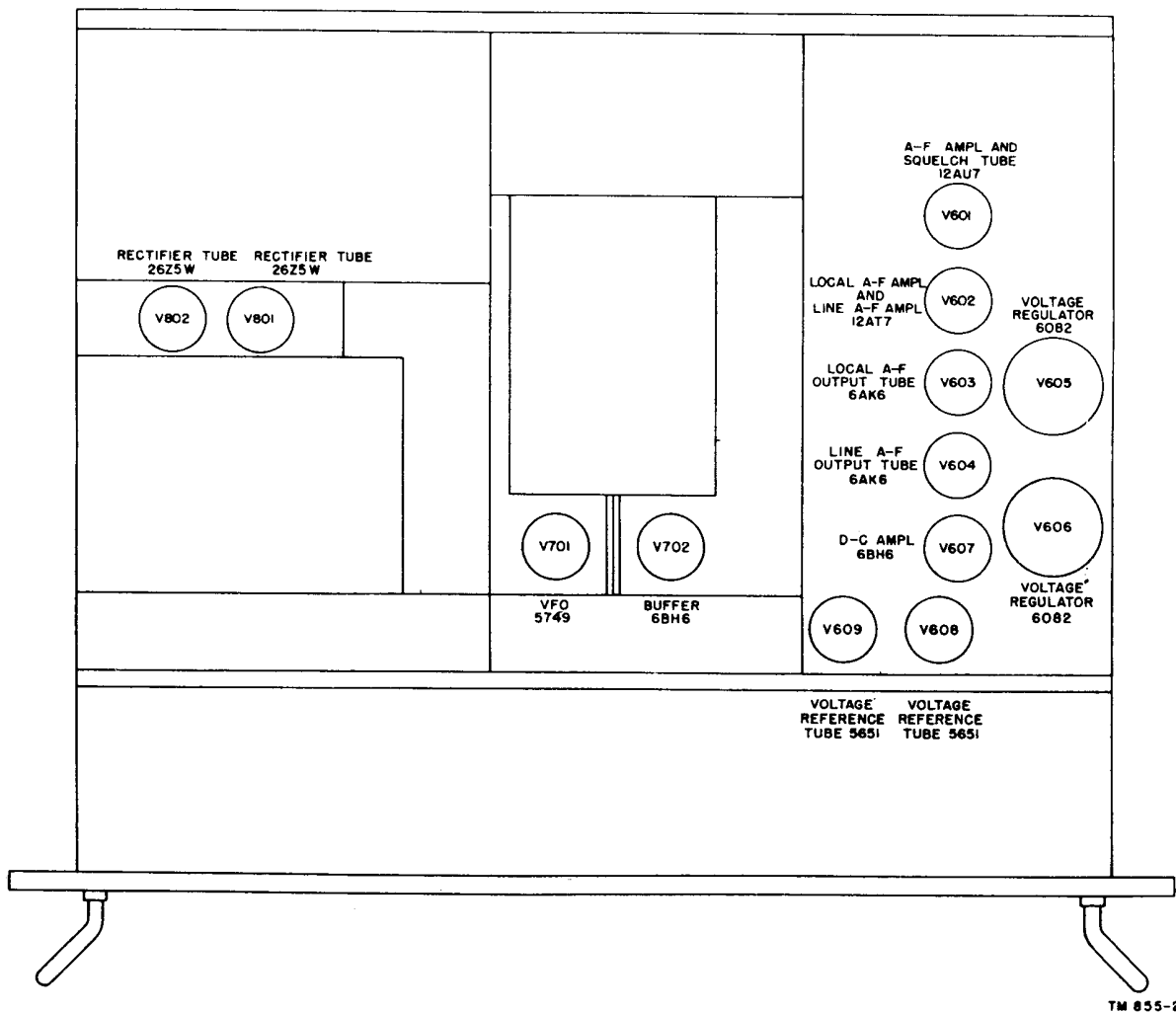

TM 855-21

Figure 6. Bottom deck, tube location.

15. Installation of Radio Receiver R-389/URR

a. Fixed, Tabletop Installation. When housed in Cabinet CY-917/URR or a similar well-ventilated case for fixed operation, place the receiver on any sturdy table or bench. Remove the top and bottom dust covers before putting the unit into the cabinet.

b. Fixed, Cabinet Installation. To install the receiver in a standard cabinet, such as Electrical Equipment Cabinet CY-1119/U, remove one of the blank panels from the cabinet and mount the receiver. Secure the front panel to the cabinet with the bolts removed from the blank panel. Insert them in the four holes located along each vertical edge of the receiver front panel.

16. Connections

Each Radio Receiver R-389/URR is shipped with jumpers between terminals 1 and 2, 3 and 4, 12 and 13, and 15 and 16 of the rear terminal strips (fig. 7). These four jumpers are required for normal operation.

Warning: The voltages used are high enough to endanger human life. To prevent shock hazard to personnel touching outside metal parts of the receiver, connect terminal 9 or 10 (marked GND) on the rear panel (fig. 7) to a ground connection in the earth.

a. Power Input (fig. 8). Connect Power Cable Assembly CX-1358/U between the power source and POWER receptacle J102.

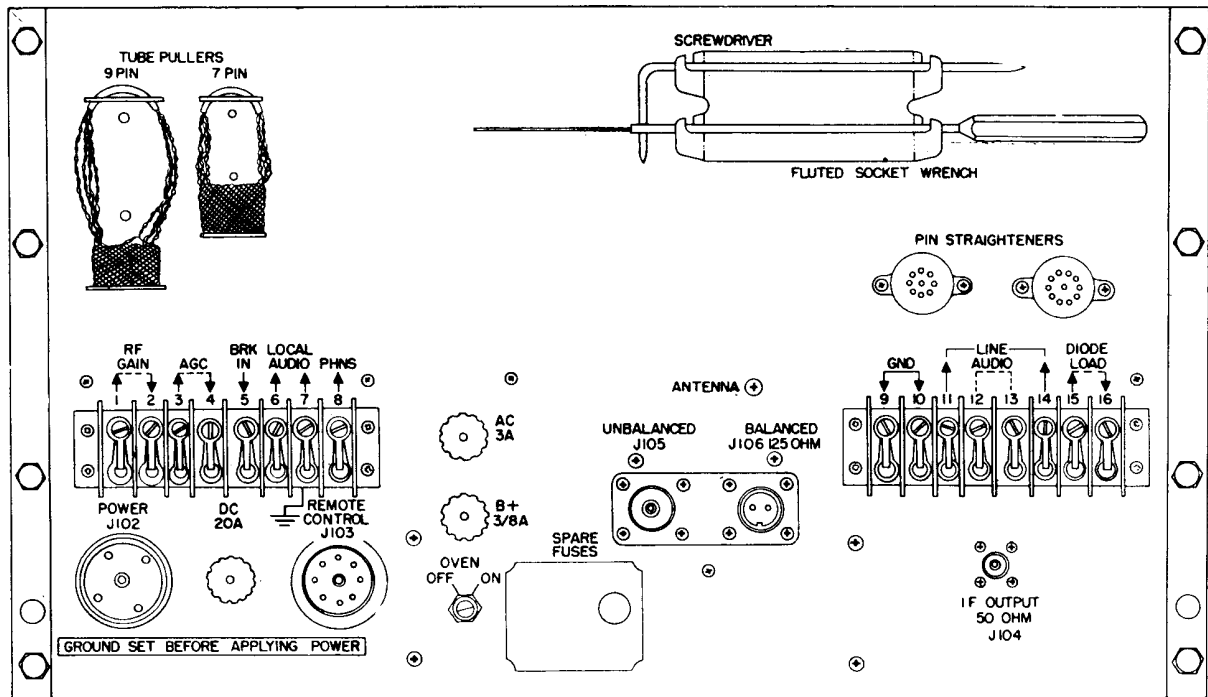

TM 855-16

Figure 7. Back panel.

b. *Antenna.* Connect the antenna to either the ANTENNA UNBALANCED or BALANCED 125 OHM connector (fig. 7) on the back panel as follows:

- (1) *ANTENNA UNBALANCED receptacle.* When an unbalanced antenna, such as a random-length wire is to be used in fixed installations, the lead-in must be connected to UNBALANCED receptacle J105 (Receptacle Connector UG-568/U) by means of Plug Connector UG-573/U.
- (2) *ANTENNA BALANCED 125 OHM receptacle.* ANTENNA BALANCED 125 OHM receptacle J106 (Receptacle Connector UG-422/U) furnishes input to the receiver through a tuned antenna transformer. This receptacle is used for all balanced antennas, and should be used for unbalanced, low-impedance transmission lines. Connect the balanced coaxial cable, Radio Frequency Cable RG-22/U, to J106 with Plug Connector UG-421/U, or, when Cable RG-86/U transmission line is used, use Plug Connector UG-969/U. Two right-angle

adapters are available for connecting the unbalanced coaxial cable to ANTENNA BALANCED 125 OHM receptacle J106. Adapter Connector UG-970/U adapts unbalanced coaxial lead-in terminated in Plug PL-259 to the receptacle, while Adapter Connector UG-971/U is used to connect unbalanced coaxial lead-in terminated in Plug Connector UG-573/U. Adapter Connector UG-971/U and Plug Connector UG-573/U are preferred, and should be used when available.

c. *Audio Output.*

- (1) A 600-ohm head set or speaker may be connected as indicated below:
 - (a) Insert the headset plug into the PHONES jack on the front panel (fig. 9), or connect a headset between LOCAL AUDIO terminal 7 and PHNS terminal 8 on the back panel (fig. 7).
 - (b) Connect the loudspeaker between LOCAL AUDIO terminals 6 and 7 on the back panel (fig. 8).

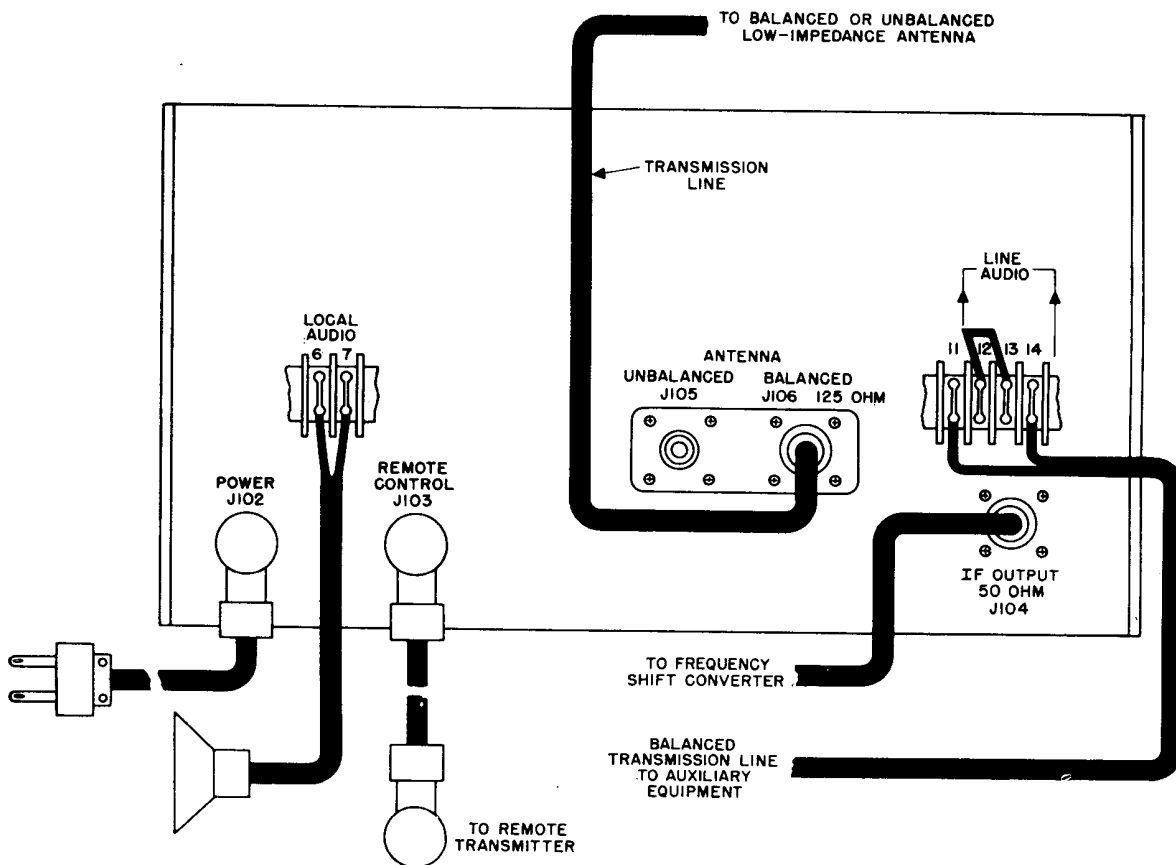

TM 855-14

Figure 8. Cording diagram.

(2) A 600-ohm balanced line for telephone and similar applications may be connected as follows:

- (a) For normal balanced-line operation, connect the line between LINE AUDIO terminals 11 and 14 on the back panel. Do not remove the jumper on terminals 12 and 13.
- (b) If a balancing bridge is to be used for long-distance line applications, remove the jumper from terminals 12 and 13 on the back panel and connect the bridge between these terminals. Connect the balanced line between terminals 11 and 14.

d. Auxiliary Connections (fig. 7).

- (1) *Break-in relay.* Connection to the break-in relay is completed through BRK IN terminal 5 on the back panel. The break-in relay operates to disable the re-

ceiver when the BREAK IN switch on the front panel is set at ON and terminal 5 on the back panel is grounded remotely.

- (2) *External diode load.* DIODE LOAD terminals 15 and 16 on the back panel are provided only for test purposes in this equipment. Terminals 15 and 16 must be connected together for normal receiver operation.
- (3) *External rf gain control.* For external control of the rf gain of the receiver, disconnect the internal RF GAIN control and connect a 5,000-ohm control externally. To substitute the external control for the internal RF GAIN control, remove the jumper between RF GAIN terminals 1 and 2 on the back panel and connect the external control between terminal 1 and terminal 9 (ground).
- (4) *Age circuit.* For external automatic

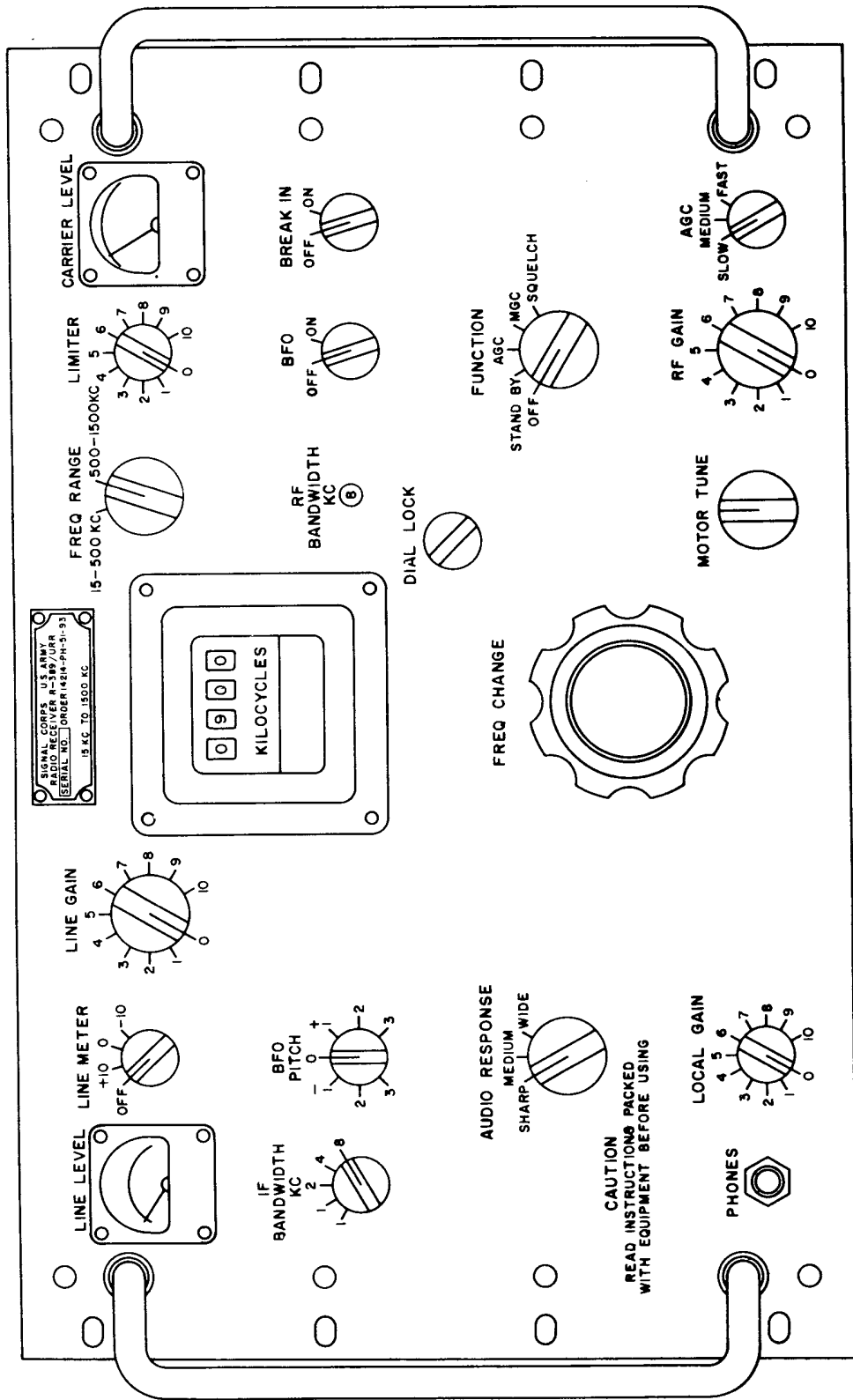

TM 855-17

Figure 9. Front panel.

gain control (agc) of the receiver, remove the jumper between AGC terminals 3 and 4 on the back panel, connect the negative lead of the external agc to terminal 4, and connect the other agc lead to terminal 9 (ground).

17. System Connections

To connect Radio Receiver R-389/URR to auxiliary equipment for reception of radioteletype signals, refer to paragraph 16 for normal operating and auxiliary connections for the desired mode of operation. Connect IF. OUTPUT 50 OHM receptacle J104 to the input channel of Frequency Shift Converter CV-115/URR.

18. Service Upon Receipt of Used or Reconditioned Equipment

a. Follow the instructions in paragraph 14 for uncrating, unpacking, and checking the equipment.

b. Examine the used or reconditioned equipment for tags or other indications pertaining to changes in the wiring of the equipment. If any changes in the wiring have been made, note the change in this manual, preferably on the schematic diagrams.

c. Check the operating controls for ease of rotation. If lubrication of the **FREQ CHANGE** control seems necessary, refer to the lubrication instructions in paragraph 111.

Section II. CONTROLS AND INSTRUMENTS

Note. This section locates, illustrates, and describes the use of the various controls and the instruments that are provided for the proper operation of the equipment.

19. General

Haphazard operation or improper setting of the controls can cause damage to electronic equipment. For this reason, it is important to know the function of every control. The actual operation of the receiver is discussed in paragraphs 21 through 28.

20. Radio Receiver R-389/URR Controls and Instruments

(fig. 9)

The following table lists the controls of the radio receiver and indicates their functions:

Control or Instrument	Function
LINE LEVEL meter.....	Indicates level of balanced-line output.
LINE METER switch.....	In OFF position, switch disconnects LINE LEVEL meter from balanced-line output. In +10 position, add 10 decibels (db) to LINE LEVEL meter vu reading; in 0 position, read LINE LEVEL meter directly in vu; in -10 position, subtract 10 db from LINE LEVEL vu reading.
LINE GAIN control.....	Controls level of af signal applied to balanced-line output terminals.
FREQ RANGE switch.....	Selects either 15- to 500-kc range, or 500- to 1,500-kc range, and moves dial mask for displaying counter for that range.
LIMITER control.....	In the 0 position, limiter does not operate. As knob is turned clockwise, peak signal impulses are cut off to reduce noise interference. Increased clockwise rotation gives more reduction of signal peaks.
CARRIER LEVEL meter.....	Indicates level of incoming rf signal. Indication of 0 db when RF GAIN control is fully on corresponds to an input signal of 2 to 5 microvolts (mv).
IF. BANDWIDTH switch.....	Selects width of the pass band in kc for 455-kc if. amplifier stages.
BFO PITCH control.....	Changes tone of cw signals.
RF BANDWIDTH indicator.....	Shows maximum width of pass band to which IF. BANDWIDTH control may be set at operating frequency of receiver.
BFO switch.....	In ON position, places beat-frequency oscillator in operation.
BREAK IN switch.....	In ON position, permits break-in operation when installation provides for it.
AUDIO RESPONSE switch.....	Varies response of audio amplifier. In SHARP position, 800-cps signal is loudest. In MEDIUM position, 3,500-cps signal is highest frequency heard. In WIDE position, all frequencies passed by if. amplifiers are heard.
DIAL LOCK.....	Rotates clockwise to lock FREQ CHANGE control.

Control or Instrument	Function
FUNCTION switch.....	<p>When rotated to any position other than OFF, connects receiver to power source and selects desired receiver function. The positions and functions are as follows:</p>
	<p style="text-align: center;"><i>Position</i> <i>Function</i></p>
	<p>STAND BY.... Receiver disabled but filaments remain lighted and vfo remains on; receiver ready for instant use.</p>
	<p>AGC..... Gain is controlled automatically for normal reception.</p>
	<p>MGC..... Age disabled; gain is controlled manually by RF GAIN control or an external gain control.</p>
	<p>SQUELCH.... Squelch circuit is connected for silencing receiver when input signal falls below threshold determined by setting of RF GAIN control.</p>
LOCAL GAIN control.....	<p>Controls level of audio-frequency signal heard in phones or loudspeaker.</p>
FREQ CHANGE control.....	<p>Tunes receiver to the desired frequency within the selected range and operates the frequency dial.</p>
MOTOR TUNE switch.....	<p>Controls tuning motor that operates the FREQ CHANGE control. Its use aids in making large frequency changes.</p>
RF GAIN control.....	<p>Controls gain of rf and if. amplifiers. When squelch circuit is operative, controls squelch threshold.</p>
AGC time constant switch.....	<p>Determines speed of change in gain of receiver for a certain change of signal strength. In FAST position, the time constant is .01 second; in MEDIUM position, .49 second; and in SLOW position, 4 seconds.</p>
OVEN switch.....	<p>Screwdriver adjustment on back panel. In ON position, turns on vfo heater for increased frequency stability (fig. 7).</p>

OPERATION

Section I. OPERATION UNDER USUAL CONDITIONS

Warning: The voltages employed are sufficiently high to endanger human life. Every precaution should be taken by personnel to minimize the danger of shock. See that one of the GND terminals on the back panel (9 or 10) is grounded.

21. Starting Procedure

Caution: The power supply of the receiver must be set to the correct ac input voltage. Refer to paragraph 14c(7). Be sure that all the external connections to the receiver are satisfactory for the desired type of operation outlined in paragraphs 16 and 17.

a. If the receiver is operated under low-temperature conditions, or in a location where there are large changes in temperature, set the screwdriver adjusted OVEN switch on the back panel to ON. When the set is operated in a temperature-regulated building or when maximum frequency stability is not required, set the OVEN switch to OFF.

b. Turn the FUNCTION switch to AGC. Allow the receiver to warm up for several minutes before operating. If the FREQ RANGE and FREQ CHANGE controls are positioned to the same channel on which operation was last performed, the operational procedure may be continued without delay. If further tuning is required, carry out the procedure given in paragraph 22.

22. Tuning Procedure

To tune Radio Receiver R-389/URR to the desired frequency, proceed as follows:

a. Turn the FREQ RANGE control to the range that includes the frequency to be received.

b. Rotate the FREQ CHANGE control to the exact frequency to be received. The MOTOR TUNE control may be used to aid in tuning rapidly to the desired frequency.

Caution: Do not turn the FREQ RANGE switch from the low range (15-500 KC) to the high range (500-1500 KC) if the FREQ

CHANGE control has been turned to its highest point. Tune the FREQ CHANGE control to about 15 kc below its highest point before changing ranges.

23. Voice Reception

a. Set the BFO to OFF, the LINE GAIN to 0, the RF GAIN to 10, the LOCAL GAIN to 5, the IF. BANDWIDTH to 1, the AUDIO RESPONSE to MEDIUM, the AGC to MEDIUM, and the LIMITER to 0 (off).

b. Adjust the FREQ CHANGE control to obtain the highest reading on the CARRIER LEVEL meter while the desired signal is being received. If it is difficult to tune in the station, turn the IF. BANDWIDTH switch to 2 or 4 and tune for best reception. Return the IF. BANDWIDTH switch to 1 and adjust the FREQ CHANGE control for the highest reading on the CARRIER LEVEL meter.

c. If the receiver is subject to vibration or bumping, tighten the dial lock.

d. Adjust the LOCAL GAIN control to obtain desired volume level in the headset and/or loudspeaker.

e. If noise is excessive, rotate the LIMITER control clockwise, as required.

f. If the signal is fading rapidly, set the AGC switch to FAST.

g. If interference is encountered, set the IF. BANDWIDTH switch to obtain the clearest reception.

h. To quiet the receiver between transmissions, set the FUNCTION switch to SQUELCH with no signal tuned in. Rotate the RF GAIN control counterclockwise from full-on position, as neces-

sary, to reduce high-level noise. Do not reduce the gain enough to lose the desired signal.

Note. Do not use the SQUELCH position of the FUNCTION switch if desired signals are weak or subject to fading.

i. When the balanced-line output circuit is used to feed telephone lines or other equipment, set the LINE METER switch to the required range and adjust the LINE GAIN control to obtain the desired indication on the LINE LEVEL meter.

j. If the break-in relay is connected to transmitter control circuits and the receiver is to be disabled during periods of transmission, set the BREAK IN switch to ON.

24. Tone-modulated Radiotelegraph Reception

For reception of tone-modulated radiotelegraph signals, operate the controls in the same manner as outlined in paragraph 23 for voice-modulated signals. Set the IF. BANDWIDTH control at 2 or 1 if it is necessary to reduce interference.

a. Some operators prefer to use the beat-frequency oscillator (bfo) when receiving tone-modulated signals. This practice is particularly useful in the following cases:

- (1) When the received signals are too weak to produce good reception, carefully tune the FREQ CHANGE control for the highest reading on the CARRIER LEVEL meter. Turn the BFO switch to ON and adjust the BFO PITCH control for a comfortable tone. Set the AUDIO RESPONSE switch at MEDIUM or SHARP.
- (2) When severe interference makes reading the signals difficult, carefully tune the FREQ CHANGE control for the highest reading on the CARRIER LEVEL meter. Turn the IF. BANDWIDTH control to 1 or .1 and check the tuning of the FREQ CHANGE control. Turn the BFO switch to ON and adjust the BFO PITCH control for a comfortable tone. Set the AUDIO RESPONSE switch at MEDIUM or SHARP.

b. When adjusting the AUDIO RESPONSE switch, note the fact that only frequencies close to 800 cycles per second are heard when it is set in the SHARP position. The setting of the BFO PITCH control will result in a tone of approximately 800 cycles per second. If a tone higher or

lower in frequency is desired, set the AUDIO RESPONSE switch at MEDIUM and adjust the BFO PITCH control to a more pleasing pitch.

c. Do not use the SQUELCH position of the FUNCTION switch when receiving telegraph signals. Use either the AGC or the MGC position.

25. Tape Transmission Reception

a. When continuous tape transmissions are being received, the FUNCTION switch may be set to AGC and the AGC switch set to SLOW. It may be desirable to reduce the setting of the RF GAIN control somewhat when strong signals are being received.

b. If the tape transmission is not continuous, set the FUNCTION switch to MGC and reduce the RF GAIN control to prevent blocking of the receiver. Reducing the rf gain can be used to increase the effect of the bfo.

c. Do not use the SQUELCH position of the FUNCTION switch when receiving tape transmission. Use either the AGC or the MGC position.

26. Unmodulated Radiotelegraph Reception

Operate the receiver controls in the same manner as for voice reception, with the following exceptions:

a. Set the BFO switch to ON.

b. Adjust the BFO PITCH control to obtain comfortable pitch.

c. If signal interference is encountered, set the IF. BANDWIDTH switch to the next lower position. To obtain the greater degree of selectivity, set the IF. BANDWIDTH switch to 1 or .1 and the AUDIO RESPONSE switch to SHARP. Readjust the BFO PITCH control to obtain the loudest signal.

d. For manual gain control only, set the FUNCTION switch to MGC and control the sensitivity with the RF GAIN control.

e. When receiving machine code transmission, turn the FUNCTION switch to AGC and turn the AGC switch to SLOW.

f. To reduce effects of fading, turn the FUNCTION SWITCH to AGC and turn the AGC switch to SLOW. To obtain full sensitivity, rotate the RF GAIN control to position 10.

g. Do not use the SQUELCH position of the FUNCTION switch when receiving continuous-

wave signals. Use either the AGC or the MGC position.

27. Stopping Procedure

a. When the receiver is not to be used for a short interval, but is to be maintained in a state of readiness, turn the FUNCTION switch to STAND BY. Use the STAND BY position for only short periods of time. When it is used for about 15 minutes or longer, vacuum-tube life may be shortened.

b. When the receiver is not to be used for a long interval, turn the FUNCTION switch to OFF.

28. Antijamming Instructions

When a receiver is jammed, promptly inform the immediate superior. Under any conditions do not cease operating. To provide maximum intelligibility of jammed signals, follow the operational procedure indicated for each type of operation.

a. When receiving am signals, and the jamming signal is cw, pulse, or other type of sharp noise, follow the procedure in the order indicated below, if possible, until reception is obtained.

- (1) Tune the receiver very slowly, through several dial markings on either side of the desired signal; use the FREQUENCY CHANGE control. Some separation of the desired signal from the jamming signal may be achieved.
- (2) Set the IF. BANDWIDTH switch to the position that provides the best degree of signal separation. Slowly tune it as indicated in (1) above.
- (3) If noise is severe, adjust the LIMITER control as required.
- (4) When the jamming signal is not too strong, set the FUNCTION switch to

MGC and turn the RF GAIN control down. The interfering signal may be reduced enough to permit part of the desired signal to come through.

- (5) If these steps do not provide some degree of signal separation, request a change of frequency and call sign.
- (6) Request the use of cw if this mode of operation is permissible. Cw signals are jammed less easily. Refer to *b* below.
- (7) Change the direction, length, and height of the antenna. This procedure may reduce the jamming effectiveness so that some degree of read-through is obtained.
- (8) If the jamming action is such that communication is impossible, report this fact to the immediate superior and use some other means of getting the message through. Continue to operate.

b. When receiving cw signals while the receiver is jammed by any type of signal, follow the procedure in the order indicated below, if possible, until reception is obtained.

- (1) Perform the steps in *a* (1) through (3) above.
- (2) Set IF. BANDWIDTH switch to the 1 KC or .1 KC position and the AUDIO RESPONSE switch to SHARP. Tune the receiver very carefully. It may be possible to separate the pitch of the desired signal from the jamming signal to provide readability by making a slight adjustment of the BFO PITCH control.
- (3) Set the FUNCTION switch to MGC and reduce the RF GAIN control. The sensitivity may be controlled with the RF GAIN control.
- (4) Perform the steps given in *a*(5), (7), and (8) above.

Section II. OPERATION UNDER UNUSUAL CONDITIONS

29. General

The operation of Radio Receiver R-389/URR may be difficult in regions where extreme heat, cold, humidity and moisture, sand conditions, etc., prevail. Procedures are given in paragraphs 30, 31, and 32 for minimizing the effects of these unusual operating conditions.

30. Operation in Arctic Climate

Subzero temperatures and climatic conditions

associated with cold weather affect the efficient operation of the equipment. Instructions and precautions for operations under such adverse conditions follow.

a. Handle the equipment carefully.

b. Keep the equipment warm and dry.

c. When operating in the open air, wear a knitted woolen cap over headsets that do not have rubber earpieces. Frequently, when the rubber earpieces are not worn, the edges of the ears may

freeze without the operator being conscious of this condition. Do not flex rubber earpieces. This action may render them useless. Water getting into the receivers may freeze and impede the action of the diaphragms. When this happens, unscrew the bakelite cap and remove the ice and moisture.

d. When the equipment has been exposed to cold and is brought into a warm room, moisture will condense until the equipment reaches room temperature. This condition can develop when the equipment warms up during the day after exposure during a cold night. When it has reached room temperature, dry it thoroughly.

31. Operation in Tropical Climate

When operated in a tropical climate, radio equipment can be installed in tents, huts, or, when necessary, in underground dugouts. When equipment is installed below ground level, and when it is set up in swampy areas, moisture conditions are more acute than those normally met in the tropics. Ventilation usually is poor, and the high relative humidity causes condensation of moisture on the equipment whenever the temperature of the equipment becomes lower than that of the surrounding air. To minimize this condition, turn the oven on to keep the equipment dry. The receiver should not be inclosed to such an extent that adequate ventilation usually is poor, and the high relative

32. Operation in Desert Climate

a. Conditions similar to those encountered in a tropical climate often prevail in desert areas. Use the same measures to insure proper operation of the equipment.

b. The main problem arising with equipment operation in desert areas is the large amount of sand, dust, or dirt that enters the moving parts of the equipment. The ideal preventive precaution is to house the equipment in a dustproof shelter. Since such a building seldom is available and would require air conditioning, the next best precaution is to make the building in which the equipment is located as dustproof as possible with available materials. Hang wet sacking over the windows and doors, cover the inside walls with heavy paper, and secure the side walls of tents with sand, to prevent their flapping in the wind.

c. Do not tie power cords, signal cords, or other wiring connections to the inside or outside of tents. Desert areas are subject to sudden wind squalls which may jerk the connections loose or break the lines.

d. Keep the equipment as free from dust as possible. Make frequent preventive maintenance checks (pars. 35 through 38). Pay particular attention to the lubrication of the equipment. Excessive amounts of dust, sand, or dirt that come into contact with oil and grease result in grit, which will damage the equipment.

CHAPTER 4

ORGANIZATIONAL MAINTENANCE

Section I. TOOLS AND EQUIPMENT

33. Tools and Materials

a. The tools, parts, supplies, and test equipment necessary to perform organizational maintenance are authorized by appropriate publications. Additional tools are supplied with the receiver (par. 34).

b. The tools and materials in the following list are not furnished as part of the receiver. They are required for organizational maintenance.

- 1 Tool Equipment TE-41.
- 1 Electron Tube Test Set TV-7/U or equivalent.
- 1 Multimeter TS-352/U or equivalent.
- Cheesecloth, bleached, lint-free.*
- Carbon tetrachloride.*
- Sandpaper, flint No. 000.*
- Solvent, Dry Cleaning (SD) (Fed spec No. P-S-661a)

34. Special Tools Supplied With Radio Receiver R-389/URR

The special tools supplied with the receiver are mounted on the back panel (fig. 7). The use of these tools is described in *a* through *d* below. Spare 3-ampere and $\frac{3}{8}$ -ampere fuses are mounted

*Part of Tool Equipment TE-41.

on the rear panel of the receiver, under a protective cover.

a. Tube Pullers. Two cable-grip type tube pullers are furnished; one for 7-pin miniature tubes, and the other for 9-pin miniature tubes. To remove a tube, slide a tube puller of the proper size over the tube envelope. Pull upward on the tool and, at the same time, wobble the tube slightly. After the tube has been removed from the socket, remove the tube from the tool by pushing the tube toward the handle.

b. Right-Angle Phillips Screw Driver. The No. 8 right-angle screw driver is used to remove the screws which secure dust covers, front panel, removable subchassis, and terminal strips.

c. Fluted Socket Wrench. The No. 8 fluted socket wrench is used for removing the front-panel bar knobs, the **FREQ CHANGE** knob, and for loosening the collars which secure the gears in the mechanical tuning system.

d. Pin Straighteners. The 7-pin and 9-pin straighteners are attached to the back panel. When a miniature tube is inserted into the receiver, either after maintenance or for replacement purposes, it first should be inserted into the proper pin straightener to align the pins properly.

Section II. PREVENTIVE MAINTENANCE SERVICES

35. Definition of Preventive Maintenance

Preventive maintenance is work performed on equipment (usually when the equipment is not in use) to keep it in good working order so that breakdowns and needless interruptions in service will be kept to a minimum. Preventive maintenance differs from trouble shooting and repair because its object is the prevention of certain troubles rather than their correction.

36. General Preventive Maintenance Techniques

- a.* Use No. 000 sandpaper to remove corrosion.
- b.* Use a clean, dry, lint-free cloth or a dry brush for cleaning.
 - (1) If necessary, except for electrical contacts, moisten the cloth or brush with solvent (SD) then wipe the parts dry with a cloth.

- (2) Clean electrical contacts with a small brush moistened with carbon tetrachloride; then wipe them dry with a clean cloth.

Caution: Repeated contact with carbon tetrachloride or prolonged breathing of the fumes is dangerous. Be sure that adequate ventilation is provided.

c. If available, dry compressed air can be used at a line pressure not exceeding 60 pounds per square inch to remove dust from inaccessible places; be careful, however, to avoid causing mechanical damage to delicate parts.

d. For further information on preventive maintenance techniques, refer to TB SIG 178, Preventive Maintenance Guide for Radio Communication Equipment.

37. Use of Preventive Maintenance Forms

a. The decision concerning the items on DA Forms 11-238 and 11-239 that are applicable to this equipment is a tactical decision to be made in the case of first echelon maintenance, by the communication officer/chief or his designated representative and, in the case of second and third echelon maintenance, by the individual making the inspection. Instructions for the use of each form appear on the reverse side of the form.

b. Circled items in figures 10 and 11 are partially or wholly applicable to Radio Receiver R-389/URR. Paragraph references in the ITEM column indicate paragraphs in the text which give additional or detailed information.

38. Performing Preventive Maintenance

Caution: Tighten screws, bolts, and nuts carefully. Fittings tightened beyond the pressure for which they are designed will become damaged or broken.

a. Performing Exterior Preventive Maintenance. Preventive maintenance is performed on the exterior of the equipment as follows:

- (1) Check the equipment against the table of components (par. 7), list of running spares (par. 11), and the list of additional equipment required (par. 12) to see that no components or parts are missing. Observe the general condition of the equipment.
- (2) Use a clean, lint-free cloth to remove dust, dirt, moisture, and grease from the

headset, the glass windows of the front-panel meters, front and back panels, and dust covers.

- (3) Inspect for proper seating of the antenna lead-in cable, headset and power-cord plugs, and fuses on the back panel. See that the connections to the terminal boards on the back panel are secure (fig. 7). Check the seating of the tubes and the crystal.
- (4) Operate the controls to check for binding, scraping, excessive looseness, and positive action. Rough action or binding of the **FREQ CHANGE** control indicates a damaged tuning system or the need for cleaning and lubrication.
- (5) Check for normal operation of the receiver (par. 47).
- (6) Clean and tighten the **POWER** and **REMOTE CONTROL** connectors. Use a clean, lint-free cloth. Remove grease, if necessary, with a cloth dampened in solvent (SD); then wipe the parts dry.
- (7) Inspect the case and the front and back panels for moisture and corrosion. Remove rust spots with No. 000 sandpaper. Touch up the bare spots (par. 41).
- (8) Inspect the antenna lead-in cable, power cable, headset cord, and all other external cables for cuts, breaks, fraying, deterioration, kinks, and strain. Repair the cuts in the insulation by covering them with rubber tape held in place by electrician's tape. Replace or repair torn cables (figs. 47 and 48).
- (9) Inspect the antenna, if possible, for corrosion and defective insulators. Look for loose antenna wires and poor connections.
- (10) Check for looseness of the front-panel control knobs. Tighten them with the fluted socket wrench provided (fig. 7).
- (11) Use a clean, damp cloth to clean the glass windows of the front-panel meters and frequency indicator; and then wipe them dry. Clean the nameplate (fig. 1).
- (12) Inspect the front-panel meters and the frequency indicator for cracked or broken glass windows (fig. 1).
- (13) If deficiencies noted are not corrected during inspection, indicate action taken for correction.

b. Performing Interior Preventive Maintenance. To perform interior maintenance, proceed as follows:

Caution: Disconnect all power before performing the following operations. Upon completion, reconnect power and check for satisfactory operation.

- (1) Remove the tubes from their sockets, one at a time, and inspect for loose envelopes and cracked sockets. Remove dust and dirt from the tube envelopes. Check the tubes for emission and short-circuited electrodes; use Electron Tube Test Set TV-7/U. Straighten the tube pins in the pin straighteners on the back panel. Replace the tubes carefully; check for adequate spring tension in the individual pin sockets. See that the tubes are seated firmly in the sockets in an upright position and that the tube shields are replaced correctly. See that corrugated metal inserts are replaced in the vfo tube shield, and that the shield is tightened down so that movement is not possible.
- (2) Inspect fixed capacitors C102, C103, and C104 on the main frame (fig. 65), and C546 and C547 on the 455-kc if. Subchassis (fig. 55), for leaks, bulges, and discoloration.

- (3) Inspect the antenna relay K101 for a loose mounting; burned, pitted, or corroded contacts; misalignment of contacts and springs; and insufficient spring tensions (fig. 72).
- (4) Inspect the resistors for cracks, chipping, blistering, discoloration, and moisture (fig. 51).
- (5) Inspect the terminals of large fixed capacitors and resistors for corrosion, dirt, and loose contacts (fig. 56).
- (6) Clean and tighten the connectors in the receiver (figs. 70 and 71).
- (7) Inspect the terminal strips for loose connections, cracks, and breaks (fig. 7).
- (8) On motor B202, inspect the brushes for wear, spring tension, arcing, and correct fit on the commutator.
- (9) Clean and tighten the connections and mountings for transformers, chokes, potentiometers, and rheostats.
- (10) Inspect transformer T801 (fig. 62) of Power Supply PP-621/URR for overheating and leakage. Inspection should be made soon after shutting down the receiver.
- (11) Check the condition of moistureproof and fungiproof material in the receiver (par. 40*b*).

Section III. LUBRICATION AND WEATHERPROOFING

39. Lubrication

No lubrication is to be performed on Radio Receiver R-389/URR at organizational maintenance level. Lubrication instruction are contained in paragraph 111.

40. Weatherproofing

a. General. Signal Corps equipment, when operated under severe climatic conditions in tropical, arctic, and desert regions, requires special treatment and maintenance. Fungus growth, insects, dust, corrosion, salt spray, excessive moisture, and extreme temperatures are harmful to most materials.

b. Tropical Maintenance. A special moistureproofing and fungiproofing treatment has been devised which, if properly applied, provides a reasonable degree of protection. This treatment is explained fully in TB SIG 13, Moistureproof-

ing and Fungiproofing Signal Corps Equipment, and TB SIG 72, Tropical Maintenance of Ground Signal Equipment.

c. Winter Maintenance. Special precautions necessary to prevent poor performance or total operational failure of equipment in extremely low temperatures are explained fully in TB SIG 66, Winter Maintenance of Signal Equipment, and TB SIG 219, Operation of Signal Equipment at Low Temperatures.

d. Desert Maintenance. Special precautions necessary to prevent equipment failure in areas subject to extremely high temperatures, low humidity, and excessive sand and dust are explained fully in TB SIG 75, Desert Maintenance of Ground Signal Equipment.

41. Rustproofing and Painting

a. When the finish on the front panel or case has been badly scarred or damaged, touch up bare

OPERATOR FIRST ECHELON MAINTENANCE CHECK LIST FOR SIGNAL CORPS EQUIPMENT										
RADIO COMMUNICATION, DIRECTION FINDING, CARRIER, RADAR										
INSTRUCTIONS: See other side										
EQUIPMENT NOMENCLATURE					EQUIPMENT SERIAL NO.					
LEGEND FOR MARKING CONDITIONS: ✓ Satisfactory; X Adjustment, repair or replacement required; ① Defect corrected. NOTE: Strike out items not applicable.										
DAILY										
NO.	ITEM	CONDITION								
		S	M	T	W	T	F	S		
1	COMPLETENESS AND GENERAL CONDITION OF EQUIPMENT (receiver, transmitter, carrying case, wire and cable, microphones, tubes, spare parts, technical manuals and accessories). PAR. 38 a (1)									
2	LOCATION AND INSTALLATION SUITABLE FOR NORMAL OPERATION.									
3	CLEAN DIRT AND MOISTURE FROM ANTENNA, MICROPHONE, HEADSETS, CHESTSETS, KEYS, JACKS, PLUGS, TELEPHONES, CARRYING BAGS, COMPONENT PANELS. PAR. 38 a (2)									
4	INSPECT SEATING OF READILY ACCESSIBLE "PLUCK-OUT" ITEMS: TUBES, LAMPS, CRYSTALS, FUSES, CONNECTORS, VIBRATORS, PLUG-IN COILS AND RESISTORS. PAR. 38 a (3)									
5	INSPECT CONTROLS FOR BINDING, SCRAPING, EXCESSIVE LOOSENESS, WORN OR CHIPPED GEARS, MISALIGNMENT, POSITIVE ACTION. PAR. 38 a (4)									
6	CHECK FOR NORMAL OPERATION. PAR. 38 a (5)									
WEEKLY										
NO.	ITEM	COND- TION	NO.	ITEM	COND- TION					
						S	M	T	W	T
7	CLEAN AND TIGHTEN EXTERIOR OF COMPONENTS AND CASES, RACK MOUNTS, SHOCK MOUNTS, ANTENNA MOUNTS, COAXIAL TRANSMISSION LINES, WAVE GUIDES, AND CABLE CONNECTIONS. PAR. 38 a (6)		13	INSPECT STORAGE BATTERIES FOR DIRT, LOOSE TERMINALS, ELECTROLYTE LEVEL AND SPECIFIC GRAVITY, AND DAMAGED CASES.						
8	INSPECT CASES, MOUNTINGS, ANTENNAS, TOWERS, AND EXPOSED METAL SURFACES, FOR RUST, CORROSION, AND MOISTURE. PAR. 38 a (7)		14	CLEAN AIR FILTERS, BRASS NAME PLATES, DIAL AND METER WINDOWS, JEWEL ASSEMBLIES. PAR. 38 a (11)						
9	INSPECT CORD, CABLE, WIRE, AND SHOCK MOUNTS FOR CUTS, BREAKS, FRAYING, DETERIORATION, KINKS, AND STRAIN. PAR. 38 a (8)		15	INSPECT METERS FOR DAMAGED GLASS AND CASES. PAR. 38 a (12)						
10	INSPECT ANTENNA FOR ECCENTRICITIES, CORROSION, LOOSE FIT, DAMAGED INSULATORS AND REFLECTORS. PAR. 38 a (9)		16	INSPECT SHELTERS AND COVERS FOR ADEQUACY OF WEATHER-PROOFING.						
11	INSPECT CANVAS ITEMS, LEATHER, AND CABLING FOR MILDEW, TEARS, AND FRAYING.		17	CHECK ANTENNA GUY WIRES FOR LOOSENESS AND PROPER TENSION.						
12	INSPECT FOR LOOSENESS OF ACCESSIBLE ITEMS: SWITCHES, KNOBS, JACKS, CONNECTORS, ELECTRICAL TRANSFORMERS, POWER-STATS, RELAYS, SELSYNS, MOTORS, BLOWERS, CAPACITORS, GENERATORS, AND PILOT LIGHT ASSEMBLIES. PAR. 38 a (10)		18	CHECK TERMINAL BOX COVERS FOR CRACKS, LEAKS, DAMAGED GASKETS, DIRT AND GREASE.						
19	IF DEFICIENCIES NOTED ARE NOT CORRECTED DURING INSPECTION, INDICATE ACTION TAKEN FOR CORRECTION. PAR. 38 a (13)									

DA FORM 11-238
1 MAY 51

REPLACES DA AGO FORM 419, 1 DEC 50, WHICH IS OBSOLETE.

Figure 10. DA Form 11-238.

TM 855-18

SECOND AND THIRD ECHELON MAINTENANCE CHECK LIST FOR SIGNAL CORPS EQUIPMENT			
RADIO COMMUNICATION, DIRECTION FINDING, CARRIER, RADAR			
INSTRUCTIONS: See other side			
EQUIPMENT NOMENCLATURE		EQUIPMENT SERIAL NO.	
LEGEND FOR MARKING CONDITIONS: ✓ Satisfactory; X Adjustment, repair or replacement required; ⊕ Defect corrected. NOTE: Strike out items not applicable.			
NO.	DESCRIPTION	NO.	ITEM
1	COMPLETENESS AND GENERAL CONDITION OF EQUIPMENT (receiver, transmitter, carrying case, wire and cable, microphones, tubes, spare parts, technical manuals and accessories). PAR. 38g (1)	19	ELECTRON TUBES - INSPECT FOR LOOSE ENVELOPES, CAP CONNECTORS, CRACKED SOCKETS; INSUFFICIENT SOCKET SPRING TENSION; CLEAN DUST AND DIRT CAREFULLY; CHECK EMISSION OF RECEIVER TYPE TUBES. PAR. 38d (1)
2	LOCATION AND INSTALLATION SUITABLE FOR NORMAL OPERATION.	20	INSPECT FIRM CUT-OUTS FOR LOOSE PARTS, DIRT, MISALIGNMENT AND CORROSION.
3	CLEAN DIRT AND MOISTURE FROM ANTENNA, MICROPHONE, HEADSETS, CHESTSETS, KEYS, JACKS, PLUGS, TELEPHONES, CARRYING BAGS, COMPONENT PANELS. PAR. 38g (2)	21	INSPECT FIXED CAPACITORS FOR LEAKS, BULGES, AND DISCOLORATION. PAR. 38d (2)
4	INSPECT SEATING OF READILY ACCESSIBLE "PLUCK-OUT" ITEMS: TUBES, LAMPS, CRYSTALS, FUSES, CONNECTORS, VIBRATORS, PLUG-IN COILS AND RESISTORS. PAR. 38g (3)	22	INSPECT RELAY AND CIRCUIT BREAKER ASSEMBLIES FOR LOOSE MOUNTINGS; BURNED, PITTED, CORRODED CONTACTS; MISALIGNMENT OF CONTACTS AND SPRINGS; INSUFFICIENT SPRING TENSION; BINDING OF PLUNGERS AND HINGE PARTS. PAR. 38d (3)
5	INSPECT CONTROLS FOR BINDING, SCRAPING, EXCESSIVE LOOSENESS, WORN OR CHIPPED GEARS, MISALIGNMENT, POSITIVE ACTION. PAR. 38g (4)	23	INSPECT VARIABLE CAPACITORS FOR DIRT, MOISTURE, MISALIGNMENT OF PLATES, AND LOOSE MOUNTINGS.
6	CHECK FOR NORMAL OPERATION. PAR. 38g (5)	24	INSPECT RESISTORS, BUSHINGS, AND INSULATORS, FOR CRACKS, CHIPPING, BLISTERING, DISCOLORATION AND MOISTURE. PAR. 38d (4)
7	CLEAN AND TIGHTEN EXTERIOR OF COMPONENTS AND CASES, RACK MOUNTS, SHOCK MOUNTS, ANTENNA MOUNTS, COAXIAL TRANSMISSION LINES, WAVE GUIDES, AND CABLE CONNECTIONS. PAR. 38g (6)	25	INSPECT TERMINALS OF LARGE FIXED CAPACITORS AND RESISTORS FOR CORROSION, DIRT AND LOOSE CONTACTS. PAR. 38d (5)
8	INSPECT CASES, MOUNTINGS, ANTENNAS, TOWERS, AND EXPOSED METAL SURFACES, FOR RUST, CORROSION, AND MOISTURE. PAR. 38g (7)	26	CLEAN AND TIGHTEN SWITCHES, TERMINAL BLOCKS, BLOWERS, RELAY CASES, AND INTERIORS OF CHASSIS AND CABINETS NOT READILY ACCESSIBLE. PAR. 38d (6)
9	INSPECT CORD, CABLE, WIRE, AND SHOCK MOUNTS FOR CUTS, BREAKS, FRAYING, DETERIORATION, KINKS, AND STRAIN. PAR. 38g (8)	27	INSPECT TERMINAL BLOCKS FOR LOOSE CONNECTIONS, CRACKS AND BREAKS. PAR. 38d (7)
10	INSPECT ANTENNA FOR ECCENTRICITIES, CORROSION, LOOSE FIT, DAMAGED INSULATORS AND REFLECTORS. PAR. 38g (9)	28	CHECK SETTINGS OF ADJUSTABLE RELAYS.
11	INSPECT CANVAS ITEMS, LEATHER, AND CABLING FOR MILDEW, TEARS, AND FRAYING.	29	LUBRICATE EQUIPMENT IN ACCORDANCE WITH APPLICABLE DEPARTMENT OF THE ARMY LUBRICATION ORDER.
12	INSPECT FOR LOOSENESS OF ACCESSIBLE ITEMS: SWITCHES, KNOBS, JACKS, CONNECTORS, ELECTRICAL TRANSFORMERS, POWERSTATS, RELAYS, SELSYNS, MOTORS, BLOWERS, CAPACITORS, GENERATORS, AND PILOT LIGHT ASSEMBLIES. PAR. 38g (10)	30	INSPECT GENERATORS, AMPLIDYNES, DYNAMOTORS, FOR BRUSH WEAR, SPRING TENSION, ARCING, AND FITTING OF COMMUTATOR. PAR. 38d (8)
13	INSPECT STORAGE BATTERIES FOR DIRT, LOOSE TERMINALS, ELECTROLYTE LEVEL AND SPECIFIC GRAVITY, AND DAMAGED CASES.	31	CLEAN AND TIGHTEN CONNECTIONS AND MOUNTINGS FOR TRANSFORMERS, CHOKES, POTENTIOMETERS, AND RHEOSTATS. PAR. 38d (9)
14	CLEAN AIR FILTERS, BRASS NAME PLATES, DIAL AND METER WINDOWS, JEWEL ASSEMBLIES. PAR. 38g (11)	32	INSPECT TRANSFORMERS, CHOKES, POTENTIOMETERS, AND RHEOSTATS FOR OVERHEATING AND OIL-LEAKAGE. PAR. 38d (10)
15	INSPECT METERS FOR DAMAGED GLASS AND CASES. PAR. 38g (12)	33	BEFORE SHIPPING OR STORING - REMOVE BATTERIES.
16	INSPECT SHELTERS AND COVERS FOR ADEQUACY OF WEATHERPROOFING.	34	INSPECT CATHODE RAY TUBES FOR BURNT SCREEN SPOTS.
17	CHECK ANTENNA GUY WIRES FOR LOOSENESS AND PROPER TENSION.	35	INSPECT BATTERIES FOR SHORTS AND DEAD CELLS.
18	CHECK TERMINAL BOX COVERS FOR CRACKS, LEAKS, DAMAGED GASKETS, DIRT AND GREASE.	36	INSPECT FOR LEAKING WATERPROOF GASKETS, WORN OR LOOSE PARTS. MOISTURE AND FUNGIPROOF. PAR. 38d (11)
19	IF DEFICIENCIES NOTED ARE NOT CORRECTED DURING INSPECTION, INDICATE ACTION TAKEN FOR CORRECTION.		

DA FORM 11-239
1 MAY 52

REPLACES DA AGO FORM 419, 1 DEC 50, WHICH IS OBSOLETE.

16-10-64887-1

TM 855-19

Figure 11. DA Form 11-239.

surfaces. Use solvent (SD) to remove dirt and grease.

Caution: Do not use steel wool. Small particles frequently enter the case and cause harmful internal shorting or grounding of circuits.

Section IV. TROUBLESHOOTING AT ORGANIZATIONAL MAINTENANCE LEVEL

42. General

a. The troubleshooting and repairs that can be performed at organizational maintenance level (operators and repairmen) are necessarily limited in scope by the tools, test equipment, and replaceable parts issued, and by the existing tactical situation. Accordingly, troubleshooting is based on the performance of the equipment and the use of the senses in determining such troubles as burned-out tubes and overheated transformers.

b. Paragraphs 43 through 48 assist the operator in determining which of the subchassis of the receiver is at fault and in localizing the fault in that assembly to the part, such as a tube or fuse. Repair will be limited to the replacement of those parts included in the running spares.

43. Visual Inspection

a. Failure of the equipment to operate properly may be caused by one or more of the following faults:

- (1) Improperly connected, worn, or broken power cable (par. 48).
- (2) Improperly connected, worn, or broken speaker or headset cord.
- (3) Burned-out fuse.
- (4) Grounded or broken antenna or antenna lead-in.
- (5) Improperly connected antenna lead-in.
- (6) Defective tube (check voltage-regulator tubes V605 and V606 first).
- (7) Improperly connected or seated external or internal interconnecting cables.
- (8) Loose connection on terminal strips on back panel.

b. When the receiver fails to operate and the cause is not immediately apparent, check as many of the above items as is practicable before starting a detailed examination. If possible, obtain information from the operator of the receiver regarding performance at the time the trouble occurred.

b. When a touch-up job is necessary, remove loose paint from the case and front panel, and paint with a small brush. Paint used will be semi-gloss gray enamel. When a front-panel marking has disappeared, use a fine brush and white enamel to replace the marking.

c. When visually inspecting the tubes for burned-out filaments, it may be discovered that more than one tube is not lighted. This condition can be caused by one filament burning out in a circuit having several filaments in series. All filaments, except the four connected directly across the 25.2-volt filament supply, are connected in series circuits which include two, three, or four filaments. In a series circuit, an open filament in one stage will cause another stage to appear defective. Tubes V605, V606, V801, and V802, oven heater HR701, and indicating lamps I-201 and I-202 are connected directly across the 25.2-volt filament supply. Cold-cathode, gas-filled tubes V608 and V609, also known as glow-discharge voltage regulators, do not require heated filaments. Figures 5 and 6 show the locations of all tubes in Radio Receiver R-389/URR. As an aid in locating trouble caused by an open filament circuit, the reference designations of the tubes in each filament circuit are listed below.

Series filament circuits (fig. 37)

V204, V203, and V202

V205, V212, and V213

V208, V211, V209, and V206

V210, V207, and V509

V504, V503, V502, and V501

V507 and V510

V505, V506, and V511

RT512, V508, and V701

V607, V604, V603, and V702

V602 and V601

44. Subchassis Testing

Make the simple tests outlined in *a*, *b*, and *c* below to determine in which subchassis the trouble lies. When an abnormal indication in these tests is obtained, further checking of the tubes, connectors, and fuses of the suspected subchassis often will show the source of the trouble.

Warning: To prevent electrical shock or harmful short circuits, turn off the receiver before re-

moving the plugs or touching any circuits, other than those specified below.

a. Power Supply and Af Subchassis. Set the FUNCTION switch at MGC and the AUDIO RESPONSE switch at MEDIUM. Rotate the RF GAIN, LOCAL GAIN, and LINE GAIN controls to their extreme clockwise positions. Remove tubes V507 and V510 and, with a pointed metallic probe with an insulated handle, touch tube-socket pin 1 of V510. A loud click in the speaker or headset indicates that the power supply and af subchassis are functioning. Replace the tubes after the test. If the af chassis and power supply are functioning, proceed with the test described in *b* below; if these units are not functioning, check the following:

- (1) AC 3A and B+ 3/8A fuses.
- (2) Power cable connection.
- (3) Speaker or headset.
- (4) Tubes V801 and V802.
- (5) Tubes V601 through V606.
- (6) Cable connectors on af subchassis.

b. If Subchassis. Remove plug P226 from receptacle J526 (fig. 70) and touch the contact of the receptacle with a probe. A loud click from the speaker or headset indicates that the af and if. circuits are functioning. Replace the plug. If the if. subchassis is functioning, proceed with the testing of the rf subchassis (*c* below). If the subchassis is not functioning, check the following:

- (1) Tube V510.
- (2) Tubes V501 through V507.
- (3) Connector P117 on the if. subchassis (fig. 70).

c. Rf Subchassis. The connection of the antenna to the antenna receptacle while the receiver is turned on should produce a loud clicking sound in the speaker or headset. When no sound is produced, check tubes V202 through V205.

45. Tube-Testing Techniques

a. General. When Electron Tube Test Set TV-2/U (TM 11-2261), or equal, is available, test the tubes (according to the instructions supplied with the tester) for shorts, leakage, and either emission or mutual conductance. If a tube tester is not available, a similar receiver in good operating condition can be used to test the tubes by the substitution method described in *b* below. If another receiver is not available, the tubes can be checked by substituting spares, as described in *c* below.

Observe the following precautions when removing and replacing tubes.

- (1) Remove all power from the equipment before replacing tubes.
- (2) Test each tube and replace it in its socket before removing another tube. If it is necessary to remove more than one tube for testing, mark each one so that it can be replaced, if satisfactory, in the proper socket.
- (3) Remove the tube shields by pressing down and turning $\frac{1}{4}$ -turn counterclockwise.
- (4) Use the proper tube puller and remove the tubes carefully. Avoid excessive movement of the tube from side to side during removal because miniature tube pins are bent easily.
- (5) Straighten the pins with the pin straighteners on the rear panel of the receiver; then replace tubes in the receiver.
- (6) Do not discard tubes that were replaced with new tubes when employing the tube substitution method. These tubes should be checked on a tube checker; if good, they may be used in less critical circuits.

b. Testing Tubes by Substitution in Similar Receiver. Tune a similar receiver, known to be in good operating condition, to a strong voice signal that is not subject to fading. If possible, use a signal on one of the lower-frequency bands. Turn the FUNCTION switch to AGC and turn the RF GAIN control to position 10. Make the substitutions from the faulty receiver to the same position in the good receiver, one tube at a time. Tap the tube. If noise or a drop in volume is produced, replace the tube. Replace the tube if a decrease in the indication on the CARRIER LEVEL results, or if distortion is heard. Note that special results must be noticed for the following tubes.

- (1) When tube V509 or V510 (agc circuit) is weak, a decreased indication on the CARRIER LEVEL meter with an increase in volume may be noted. A weak V511 (agc time constant circuit) causes an increase in indication on the CARRIER LEVEL meter without any change in volume. A weak section of V511 (if. cathode follower) produces a weak signal at IF. OUTPUT 50 OHM receptacle J104.

After testing tubes V507 and V510 (noise limiters) in the usual manner, tune the receiver away from the test signal, and, if noise is received, rotate the LIMITER control clockwise; the tubes under test and tubes that are known to be good should be equally effective in reducing noise. After testing these tubes, return the LIMITER control to the 0 position and retune the receiver to the test signal. To test V508, turn the BFO switch to ON, and while turning the BFO PITCH control through its entire range, listen for the beat note.

- (2) Test tubes V801 and V802 of the power supply subchassis; V605, V606, and V607 of the af subchassis; and V701 of the vfo subchassis by listening to the audio output and watching the needle on the CARRIER LEVEL meter. Look at V608 and V609; if they do not glow properly, they will cause abnormal B+ voltage.
- (3) When testing V601, V602, and V603, listen to the output of the local audio channel. Also, when testing V601, test the operation of the squelch circuit by tuning between stations; the phones and/or loudspeaker should be silent. When testing V602 and V604, listen to the audio output from the balanced line circuit and watch the needle on the LINE LEVEL meter. Small changes in the setting of the LINE LEVEL meter may be normal because of slight differences between tubes.

c. Testing Tubes by Substituting Spares. Replace the tubes in the faulty receiver, one at a time,

with their respective spare tubes; follow the same general procedures given in *b* above.

46. Troubleshooting by Using Equipment Performance Check List

a. General. The equipment performance check list (par. 47) will help the repairman to locate trouble in the equipment. The list gives the items to be checked, the conditions under which the item is checked, the normal indications and tolerances of correct operation, and the corrective measures to be taken. To use this list, follow the items in numerical sequence.

b. Action or Condition. For some items, the information given in the action or condition column consists of various switch and control settings with which the items are to be checked. For other items, it represents an action that must be taken to check the normal indication given in the normal indications column.

c. Normal Indications. The normal indications listed are those that the repairman should see or hear when he checks the items. If the indications are not normal, the operator or repairman should apply the corrective measures.

d. Corrective Measures. The corrective measures listed are those that the operator or repairman can make without turning in the equipment for repairs. A reference in the table to a paragraph indicates that the trouble cannot be corrected during operation, and that troubleshooting by an experienced repairman is necessary. If the corrective measures do not give results, troubleshooting is necessary. If the tactical situation requires that communication be maintained and if the receiver is not completely inoperative, the operator must maintain the receiver in operation as long as possible.

47. Equipment Performance Check List

	Item No.	Item	Action or condition	Normal indications	Corrective measures
P R E P A R A T O R Y	1	Antenna.....	Lead-in wire connected.		
	2	Loudspeaker or headset.	Loudspeaker connected to LOCAL AUDIO terminals 6 and 7 or headset connected to PHONES jack.		
	3	600-ohm line.....	Connected to LINE AUDIO terminals 11 and 14. If 600-ohm line is not available, connect headset to terminals for test purposes.		
	4	Power cable.....	Connected between receiver and power source.		
	5	AUDIO RESPONSE switch.	Set at MEDIUM.		
	6	IF. BANDWIDTH switch.	Set at 4 or 8 KC.		
	7	RF GAIN control.....	Set at 10.		
	8	LOCAL GAIN control.	Set at 5.		
	9	FREQ RANGE switch.	Set at 15-500 KC.		
	10	FREQ CHANGE control.	Set at 250 KC.		
	11	LIMITER control.....	Set at 0.		
	12	Terminal strips.....	The following pairs of terminals on the rear terminal strips are connected together: 1 and 2, 3 and 4, 12 and 13, 15 and 16. External ground is connected to terminal 9 or 10 as a safety precaution.		
S T A R T	13	FUNCTION switch...	Turn to STAND BY.....	Dial lamps light.....	Check power cable (par. 48). Check dial lamps and fuses.
			Turn to AGC.....	Rushing noise or signal is heard in speaker or headset. Rf bandswitching system may be heard to cycle, depending on position of FREQ CHANGE and FREQ RANGE controls.	Look for loose or broken tubes. Check connectors between subchassis. Test tubes. Refer to paragraph 99.

Item No.	Item	Action or condition	Normal indications	Corrective measures
14	FREQ RANGE switch	Switch from 15-500 KC range to 500-1500 KC range.	Rf bandswitching system may be heard to cycle, depending on position of FREQ CHANGE control. If the cycling is not heard, switch FREQ RANGE to 15-500 KC range. Bandswitching system is heard to cycle. Return FREQ RANGE switch to 500-1500 KC range.	Refer to paragraph 99.
15	MOTOR TUNE switch.	Turn on in either direction	FREQ CHANGE knob and counter wheels rotate.	Refer to paragraph 99.
16	FREQ CHANGE control.	Tune in a station. Note indication on CARRIER LEVEL meter. Tune slowly through entire range of receiver.	Signals or noise heard throughout entire range without dead spots.	Refer to paragraph 99.
17	LOCAL GAIN control.	Rotate control in either direction.	Volume at loudspeaker or headset increases or decreases.	Refer to paragraph 99.
18	LINE METER switch.	Set to 0	Indication on LINE LEVEL meter increases or decreases.	If headset level varies and pointer of LINE LEVEL is sticking, tap meter lightly. Refer to paragraph 99. If local output is satisfactory but line output is weak, test tubes V602 and V604. Refer to paragraph 99.
19	LINE GAIN control	Rotate control		
20	RF GAIN control	Rotate control	With a station tuned in audio output and CARRIER LEVEL meter indication increases or decreases.	Refer to paragraph 99.
21	FUNCTION switch	Turn to MGC	Signal still heard; if signal is strong, receiver will block.	Refer to paragraph 99.
		Turn to AGC, and tune through several different signals.	Output volume nearly constant.	Refer to paragraph 99.
		Turn to SQUELCH; operate the FREQ CHANGE control.	If noise is high, turn the RF GAIN control counterclockwise until the output is silenced.	Test tube V601. Refer to paragraph 99.
22	LIMITER control	Return to AGC and RF GAIN control to 10 after check. Turn clockwise	Background noise is reduced in amplitude.	Refer to paragraph 99.

EQUIPMENT PERFORMANCE

	Item No.	Item	Action or condition	Normal indications	Corrective measures
EQUIPMENT PERFORMANCE	23	BREAK IN switch....	Turn to ON. Short BRK IN terminal 5 on rear panel to ground momentarily.	LINE LEVEL meter is disabled and break-in relays silence receiver. Line audio output circuits from receiver REMOTE CONTROL receptacle are disconnected from receiver output.	Refer to paragraph 99.
	24	LINE METER switch.	Turn to +10.....	Line level is 10 vu above LINE METER indication.	Refer to paragraph 99.
			Turn to 0.....	LINE METER indicates the line level controlled by the LINE GAIN control.	
			Turn to -10.....	Line level is 10 vu below LINE METER indication.	
			Turn to OFF.....	LINE LEVEL meter is disconnected. Line audio output is still connected.	
25	BFO switch and BFO PITCH control.	Turn the BFO switch to ON. Tune in a cw signal, and vary the BFO PITCH control.	Tone of signal varies.....	Test tube V508. Refer to paragraph 99.	
26	IF. BANDWIDTH switch.	Turn from 8 to .1 KC.....	Selectivity becomes sharper. A reduction of noise will be noted when the bandwidth is narrowed.	Refer to paragraph 99.	
27	AUDIO RESPONSE switch.	Operate through three positions.	In WIDE position, permits amplification of receiver's full audio range; in MEDIUM position, cuts off frequencies above 3,500 cps; in SHARP position, passes only 800 cps.	Refer to paragraph 99.	
STOP	28	FUNCTION switch...	Turn to STAND BY.....	Receiver is silent. Filament circuits and vfo circuits are kept on for immediate reception.	
			Turn to OFF.....	Turns off all receiver circuits.	

48. Checking Power Cable

A defective power cord is often the cause of an inoperative receiver. The repairman can save a great deal of time by checking Power Cable Assembly CX-1358/U cable first. Remove the connector from the ac input, and, with the cable assembly still attached to POWER receptacle J102, connect an ohmmeter across the terminals of the ac connector. Turn the FUNCTION switch to OFF; the ohmmeter should indicate infinity. With the FUNCTION switch set to STAND BY, the ohmmeter indication should be about 1.5 ohms for

115-volt ac input and 3.5 ohms for 230-volt ac input. If these conditions are not obtained, check fuse AC 3A. If the fuse is good, remove the cable assembly from the receiver receptacle, and check for a short circuit in the cord by measuring between the two terminals of the ac connector; check for a break or an open circuit by measuring between terminals A and D at the receiver end of the cable and the ac connector. If these tests show that the cable assembly is good, the fault may be assumed to be in the receiver or in other external connections.

CHAPTER 5

THEORY

Section I. THEORY OF RADIO RECEIVER R-389/URR

49. Principles of Operation

a. Radio Receiver R-389/URR provides cw, modulated continuous wave (mcw), and am. reception over a frequency range of 15 to 1,500 kc. The receiver is basically a superheterodyne of the double conversion type.

b. The receiver normally operates from a self-contained power supply designed to operate at an input of 115 or 230 volts over a frequency range of 48 to 62 cycles per second (cps).

c. The tuning system of Radio Receiver R-389/URR provides linear tuning over the entire frequency range of 15 to 1,500 kc in two manually selected ranges. The low range of 15 to 500 kc has five bands incorporating five sets of rf tuning circuits, and the high range of 500 to 1,500 kc has two bands incorporating two sets of rf tuning circuits. Permeability tuning, using shafts and gears coupled to a system of precision screws which position rack-mounted powdered-iron cores, makes possible linear tuning and the use of a countertype indicator on the front panel to show the operating frequency.

50. Block Diagram

(fig. 12)

a. The block diagram shows the signal path from the antenna to the output. A schematic diagram (fig. 89) shows the circuits in detail. A schematic diagram of each subchassis and the interconnecting wiring is shown in figure 88.

b. Power Supply PP-621/URR provides dc for the antenna and break-in relays, ac to the filament and over circuits, and B voltage to the voltage-regulator circuit. All B voltages supplied to the receiver are regulated. The voltage-regulator circuit consists of series regulator V605 and V606, dc amplifier V607, and voltage-reference tubes V608 and V609. The power supply consists of a transformer, with two primary windings connected in series for 230-volt ac operation or con-

nected in parallel for 115-volt ac operation, and rectifiers V801 and V802. Dc voltage for the antenna and break-in relay circuits is provided by dry-disk rectifier CR801.

c. Rf signals are fed to the receiver from either a balanced or an unbalanced antenna. Antenna relay K101 grounds the antenna input for break-in operation and also operates to protect the antenna circuits of the receiver during standby operation. If the balanced antenna input is used, the rf signals pass through one of several antenna transformers (selection of which is determined by the operating frequency of the receiver) and are fed to the tuned circuit of first rf amplifier V202. If the unbalanced antenna input is used, the signals are capacitance-coupled to the secondary of the selected antenna transformer and are applied to the tuned circuit of first rf amplifier V202.

d. The output of first rf amplifier V202 is coupled to the grid of second rf amplifier V203. The gain of the first and second rf amplifiers is controlled manually by the RF GAIN control and automatically by the agc voltage. These stages amplify the rf signals (15 to 1,500 kc) before applying them to first mixer V204.

e. The first mixer circuit combines the rf signal with a heterodyning signal, supplied by mixer driver V206, to produce a first intermediate frequency of 10 megacycles. The 10-mc signal is fed directly from the output of the first mixer to second mixer V205. The heterodyning signal for this mixer is supplied by crystal oscillator V207. Second mixer V205 combines the 10-mc signal with the 10,455-kc signal, supplied by crystal oscillator V207, to produce a second intermediate frequency of 455 kc.

f. The frequency of the receiver is determined by vfo V701. The output frequency of vfo V701 is variable from 470 to 977.5 kc and is fed to buffer V702. Buffer V702 amplifies the fundamental

vfo signal when the receiver is operating in the 15- to 500-kc range, or amplifies the second harmonic frequency of the vfo signal when the receiver is operating in the 500- to 1,500-kc range. The output frequency range of buffer V702 is 470 to 1,955 kc and is fed directly to phase inverter V211. Signal voltages of equal amplitude but of 180° phase difference are taken from the plate and cathode circuits of the phase inverter and are applied to injection mixer tubes V212 and V213. A 10,455-kc signal supplied by crystal oscillator V207 is heterodyned with the 470- to 1,955-kc signal from phase inverter V211 by the injection mixer stage to produce a difference frequency in the range of 8.5 to 9.985 mc. Signal voltage from injection mixers V212 and V213 is applied to input coupler V208. Input coupler V208 serves to match the input impedance of low-pass filter FL201. Signal voltages below 10 mc are passed by filter FL201, and frequencies above 10 mc are greatly attenuated. The signal from the filter is applied to the output coupler V209, which serves to match the terminal impedance of the filter. Output coupler V209 amplifies the injection voltage sufficiently for application to first mixer V204 through mixer driver V206. The frequency of the injection signal supplied by mixer driver V206 for heterodyning is 8.5 to 9.985 mc. Note that the second if. of 455 kc is constant, even though 10,455-kc crystal oscillator V207 may drift in frequency. A change in crystal-oscillator output frequency produces a similar change in the first-mixer injection voltage and is followed by a corresponding change in the first if. Because the first if. is heterodyned against the crystal-oscillator frequency by the action of second mixer V205, the resulting second if. is exactly 455 kc. Any frequency drift is due only to the vfo.

g. The 455-kc output signal of second mixer V205 is applied to the grid of first if. amplifier V501, either directly or through crystal filter Z501, depending on the bandwidth desired. For the two narrow pass bands, .1 and 1 kc, the crystal filter is used. Three additional degrees of selectivity which do not use the crystal filter are provided in the if. stages by the IF. BANDWIDTH switch to vary the coupling between the primary and secondary circuits of the if. transformers. (Actually four degrees of selectivity are provided, one of which is not used.) The if. amplifier consists of six stages, V501 through V506, which, together with the associated transformers, provide

the required pass band. The output of fifth if. amplifier V505 is divided to supply a 455-kc signal to each of three stages: sixth if. amplifier V506, agc if. amplifier V509, and the if. cathode follower, one-half of V511. The output signal of the sixth if. amplifier is demodulated in the detector circuit, one-half of V507. An external diode load can be connected between DIODE LOAD terminal 16 of TB103 and ground, with the jumper between terminals 15 and 16 removed. The output of the fifth if. amplifier is amplified in agc if. amplifier V509, and the resulting signal is rectified by the agc rectifier, one-half of V510. When the FUNCTION switch is set to AGC, the gain of rf amplifiers V202 and V203 and of if. amplifiers V501 and V505 is controlled automatically by a dc voltage developed by the agc rectifier, one-half of V510, to keep the output level of the receiver relatively constant and independent of signal-strength variations at the antenna. Thus, for strong signals, the grid bias is high and the gain of the controlled stages is reduced; and for weak signals, the grid bias is reduced and gain of the controlled stages is increased. The response rate of the agc circuits can be controlled to satisfy reception requirements through use of the AGC switch, the agc time constant circuit, and one-half of tube V511. For manual-gain control, the agc circuit is grounded by setting the FUNCTION switch to MGC. The if. cathode follower, one-half of V511, provides a low-impedance output connection (50 ohms) at IF. OUTPUT 50 OHM receptacle J104, for connection of auxiliary equipment when the receiver is employed for frequency-shift teletypewriter reception.

h. To permit reception of radiotelegraph signals, beat-frequency oscillator (bfo) tube V508 provides a signal in the frequency range of 452 to 458 kc. This signal is heterodyned with the 455-kc if. output signal of sixth if. amplifier V506 to produce a beat frequency in the output of the detector which is in the af range. The output of the detector, one-half of V507, is coupled to the af amplifier, one-half of V601, through a negative peak limiter, one-half of V507, and a positive peak limiter, one-half of V510, which together prevent noise peaks from exceeding average signal level. The degree of limiting is controlled by a front-panel control marked LIMITER. If operation without limiting is desired, the limiters can be disabled by rotating the LIMITER control completely counterclockwise.

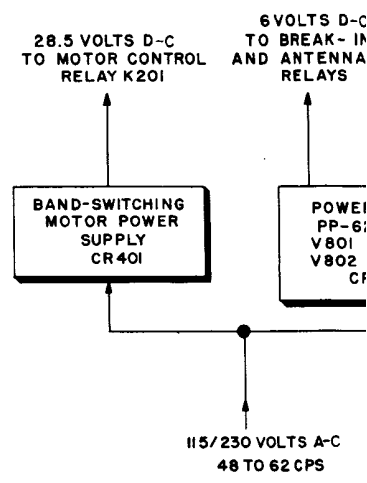
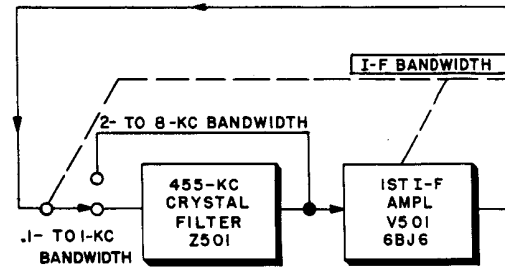
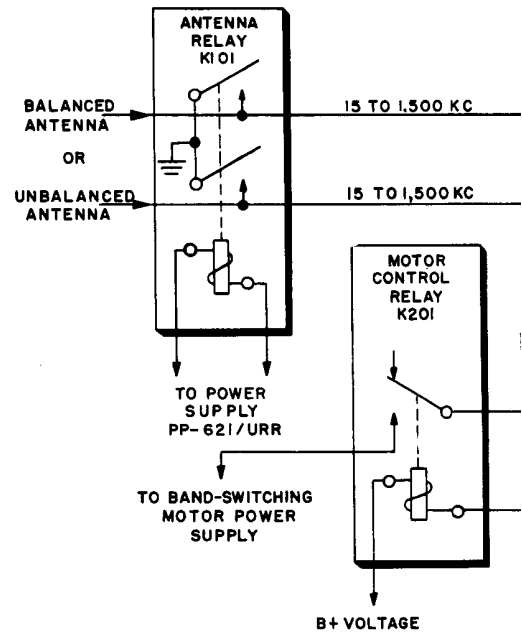

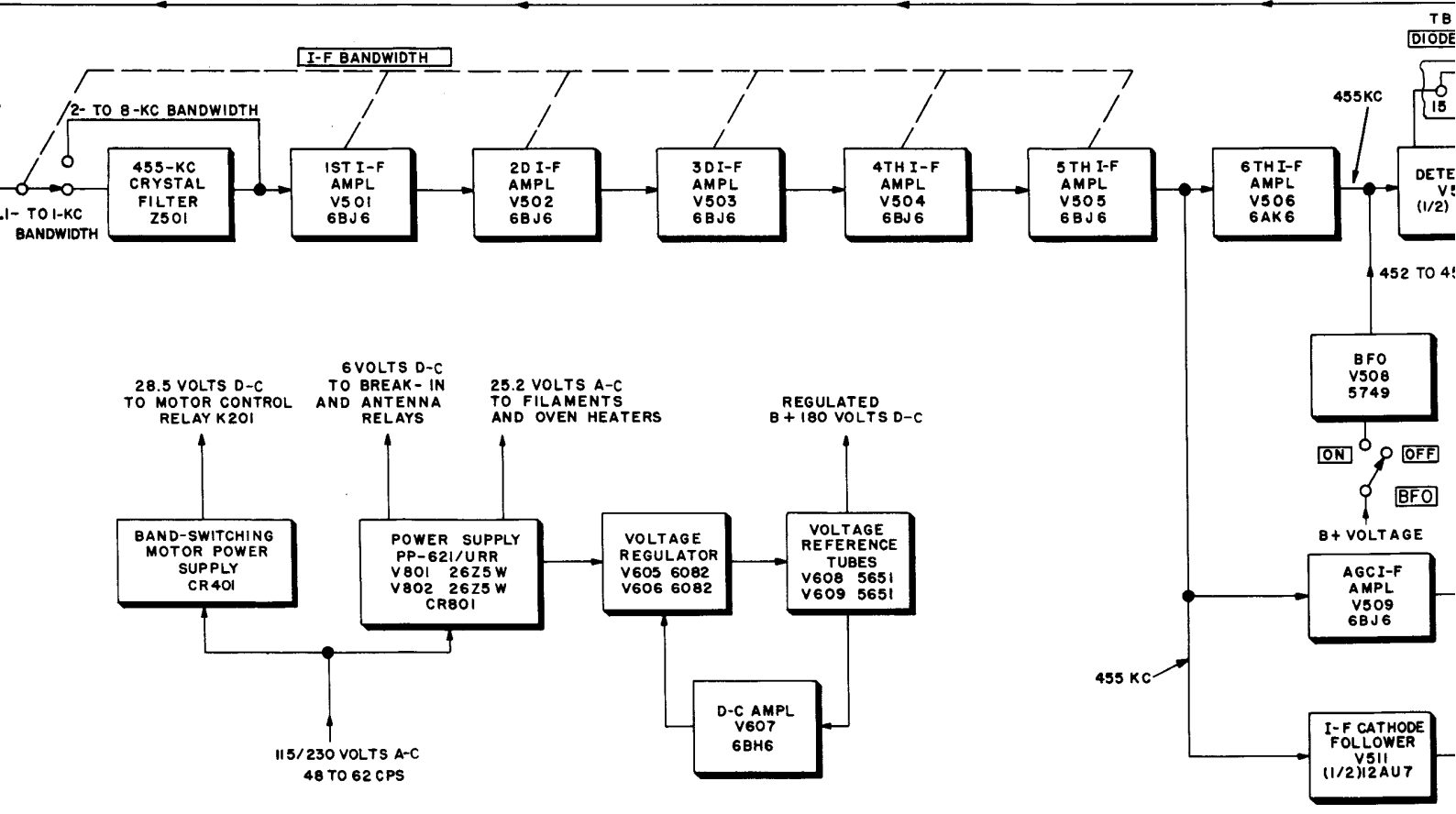
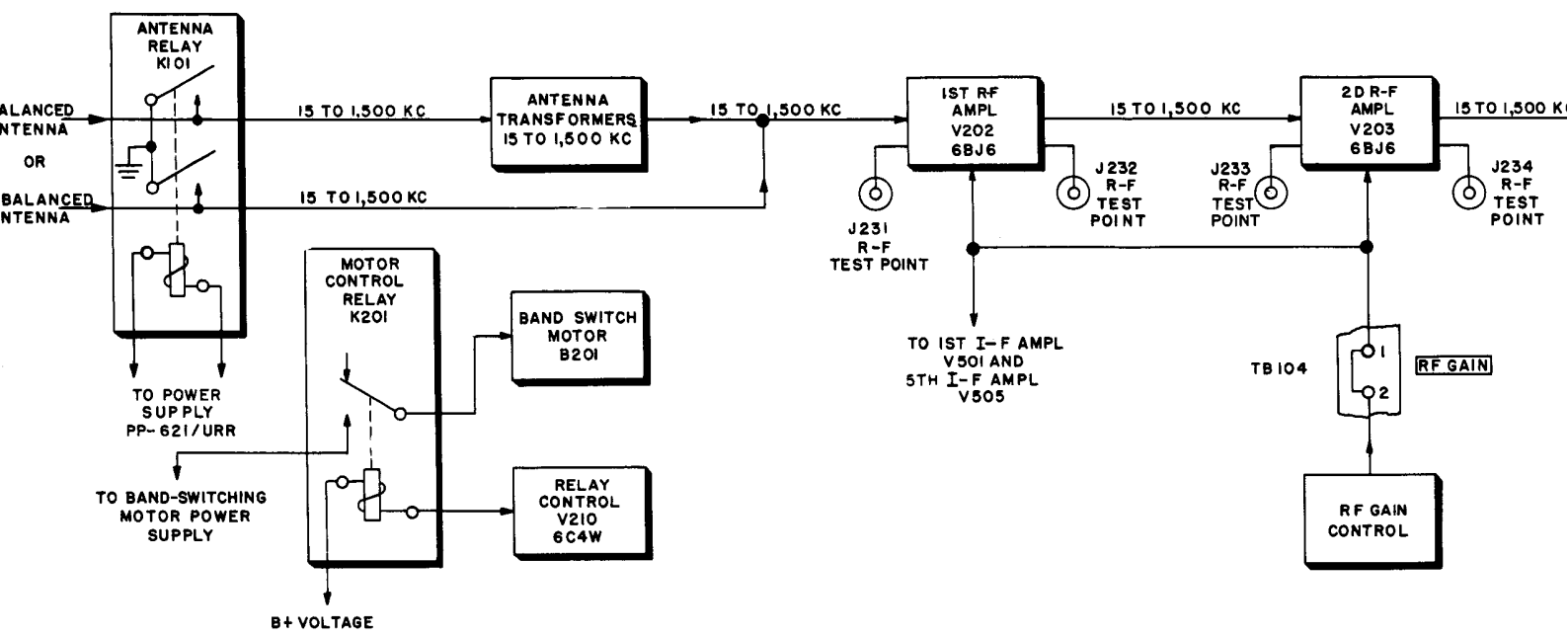
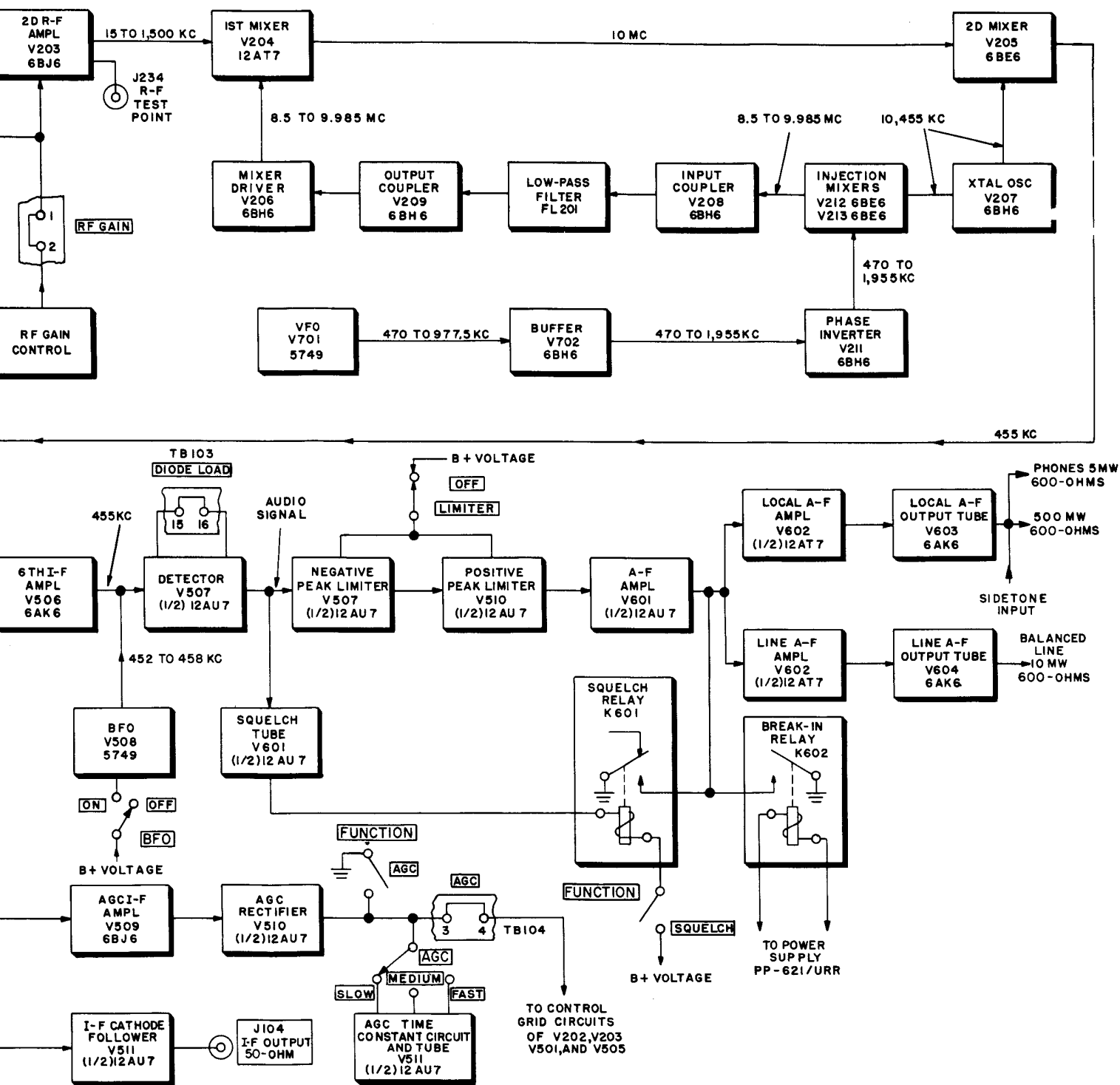

Figure 12. Radio Receiver R-389/URR, block diagram.



Receiver R-389/URR, block diagram.

i. In addition to supplying demodulated signals to the limiter, the detector, one-half of V507, supplies a dc signal to the squelch tube, one-half of V601, which is a voltage amplifier. The average dc output voltage of the squelch tube varies in proportion to the average signal level. When the signal level drops below some predetermined level established by the setting of the RF GAIN control, and when the FUNCTION switch is set to SQUELCH, the dc passing through the squelch tube operates squelch relay K601, which, in turn, short-circuits the output of af amplifier V601 to quiet the receiver output. The output of the af amplifier also can be shorted to ground by break-in relay K602, when the FUNCTION switch is set to STAND BY; or to either MGC, AGC, or SQUELCH, when the BREAK IN switch is set to ON and an external circuit provides a ground. The output from the af amplifier, one-half of V601, is divided and applied through separate gain controls to a local af amplifier, one-half of

V602, and to a line af amplifier, the second half of V602. The output of the local af amplifier supplies signals to local af output tube V603, which has connections for a speaker or a headset and for sidetone signals from an associated transmitter to permit monitoring. The line af amplifier supplies signals to line af output tube V604, which has connections for a balanced line.

j. The band-switching-motor power supply delivers 28.5-volt dc power to band-switching motor B201. Dc voltage is provided by dry-disk rectifier CR801.

k. Selection of tuned circuits for any band throughout the frequency range of the receiver is obtained through automatic operation of band-switching motor B201. The operation and function of this system is discussed in detail in paragraphs 87 through 89. Briefly, a dc current passing through relay control V210 operates motor control relay K201, which, in turn, supplies 28.5 volts dc to operate band-switching motor B201.

Section II. CIRCUIT ANALYSIS

51. General

The construction of Radio Receiver R-389/URR is unitized; five subchassis are mounted on a main frame. Certain component parts are mounted on subchassis that contain no related electrical circuits. Discussions of the circuits in this section are based on the signal paths established in the block diagram (fig. 12) and in the overall schematic diagram (fig. 89).

52. Antenna Circuit

(fig. 13)

The antenna circuit provides for coupling various types of antennas to the input of first rf amplifier V202.

a. Balanced antennas that have a terminal impedance of 70 to 200 ohms are connected to the input circuit of the first rf amplifier through a matching transformer. One of seven matching transformers (T201 through T207) is selected automatically by a band-switching motor as the FREQ RANGE and FREQ CHANGE controls are operated. The matching transformer selected depends on the frequency to which the receiver is tuned. Connection to the proper transformer is made through selections 1 and 2 of band switch S201, which receives the incoming signal from

ANTENNA BALANCED J106 125 OHM jack through coaxial connectors J111 and J110 and their mating connectors P211 and P210 respectively. Although seven transformers are used to cover the frequency range of 15 to 1,500 kc in seven bands, the theory of operation is the same for all bands. Only one band is shown in the schematic diagram (fig. 13). This method of simplification will be used, wherever possible, in the discussion of succeeding stages.

b. Capacitor C106 serves to balance the primary circuit with respect to ground.

c. The powdered-iron core shown between L202 and L203 is moved by the FREQ CHANGE control to tune the transformer within its frequency range. The powdered-iron core shown at L201 is adjusted when the receiver is aligned; it permits accurate tracking with the other tuning circuits. The resonant circuit is formed by capacitors C201 and C202, connected in parallel across the secondary windings of transformer T201. The voltage developed across this resonant circuit is applied through resistor R203 to the resonant circuit formed by Z201, C216, and C217. Seven such resonant circuits (Z201 through Z207 and their associated capacitors) are used throughout the entire frequency range in the same manner as the antenna matching transformers. The voltage de-

veloped across tuned circuit Z201 is applied through switch S201D, jack J222-A, and plug P222-A, and coupling capacitor C224, to the control grid (pin 1) of first rf amplifier V202. Signals from random-length, unbalanced antennas are applied from J105 through C105, J109, P209, S201C, to secondary winding of 8201.

d. Antenna relay K101 is operated through the break-in relay circuit. It grounds both antenna-input circuits when an associated transmitter is in operation and during standby operation. Resistor R126 prevents the gradual accumulation of a static electrical charge on the antenna and, if an unusually strong voltage is induced (such as might be caused by transmission from an adjacent transmitter), glow tube I 101 conducts momentarily and passes the charge to ground. Glow tube I 101 is used to protect the input circuits during the instant when a nearby transmitter is turned on and relay K101 has not had time to close.

e. Wafers S201A through S201D are sections of a seven-position band switch which is operated by band-switching motor B201 to select the appropriate frequency-determining elements for the band in use. The band-switching operation is described in detail in paragraphs 87 through 89. The antenna circuit is designed to cover a range of 15 to 1,500 kc in seven bands, as follows: 15 to 27 kc, 27 to 55 kc, 55 to 117 kc, 117 to 242 kc, 242 to 500 kc, 500 to 865 kc, and 865 to 1,500 kc.

53. First Rf Amplifier V202

(fig. 13)

The first rf amplifier uses a miniature pentode tube, type 6BJ6, to increase the amplitude of the signals from the antenna before they are applied to the second rf stage. The following information pertains only to the 15- to 27-kc band, since operation on the other bands is the same.

a. When the FUNCTION switch is set to AGC, grid bias for the first rf amplifier is supplied from the agc circuit through P128-9 and J228-9, J222-N and P222-N, decoupling resistor R215 (which is bypassed by capacitor C236), and grid resistor R234. When the FUNCTION switch is set to the MGC position, the agc line is grounded, and grid bias is controlled by RF GAIN control R105. Cathode resistor R217 provides minimum bias. To prevent degeneration in the first rf stage, a low-impedance signal circuit from cathode to ground is provided by capacitor C226. Resistor R105 also controls the gain of second rf ampli-

fier V203 (through R236) and of first and fifth if. amplifiers V501 and V505 (through P117-16 and J517-16). Capacitor C102 provides a low-reactance path to ground at rf and if. and acts as a noise filter when the RF GAIN control is operated. An external rf gain control may be connected between terminals 1 and 7 (GND) of TB104, provided that the jumper between terminals 1 and 2 (RF GAIN) is removed. The screen-grid (pin 6) voltage is applied through voltage-dropping resistor R218 from the output of the 180-volt supply through P222D and J222D, decoupling resistor R201, J228-2 and P128-2, and FUNCTION switch S107. Resistor R219 is connected from the screen grid to ground as a bleeder to minimize variations in screen voltage caused by screen-current changes. Rf signal voltages on the screen are bypassed to ground through capacitor C227. Plate voltage is applied to V202 through P221A and J221A, switch section S201E, tuned circuit Z208, decoupling resistor R201, J228-2 and P128-2, and FUNCTION switch S107. Resistor R201 and bypass capacitor C214 function as a decoupling filter to prevent rf signals in the plate circuit and screen circuit from entering the common B circuits. Voltage for the plate and screen circuits is applied through FUNCTION switch S107 in all positions except STAND BY and OFF. For a detailed analysis of the operation of the FUNCTION switch, see paragraph 85.

b. Signals from the antenna circuit are applied, through coupling capacitor C224, to the control grid (pin 1) of the first rf amplifier. The amplified signals which appear at the plate (pin 5) are applied through P221-A and J221-A, and switch S201E, to tuned circuit Z208. The output of the first rf stage is taken from the junction point of R220 and R221, two series resistors which serve as a voltage divider across tuned circuit Z208. Capacitors C228 and C229 form a resonant circuit with Z208. The series resistors (R220 and R221) across tuned circuit Z208 reduce the Q of the tuned circuit, which increases bandwidth. To obtain approximately equal rf gain throughout the range of the receiver, compensation for differences in gain versus frequency is provided by shunt resistors having different ratios and total series resistance values for each tuned circuit, Z208 through Z214 (fig. 89). The output signals of the first rf amplifier, taken from the junction of the resistors, are applied through switch S201F, J222-P and

FROM →
POWER →
SUPPLY →
PP-621/URR



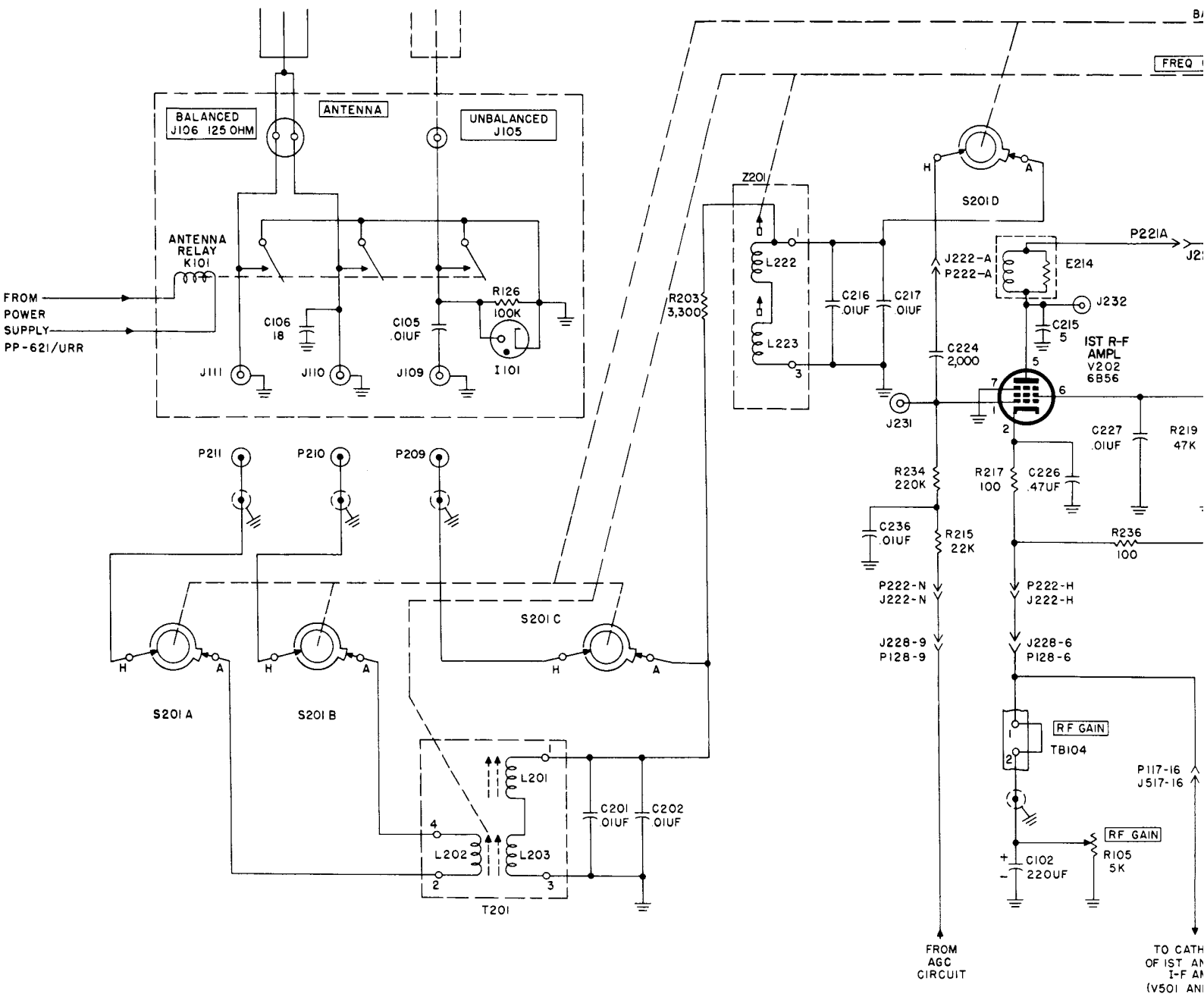
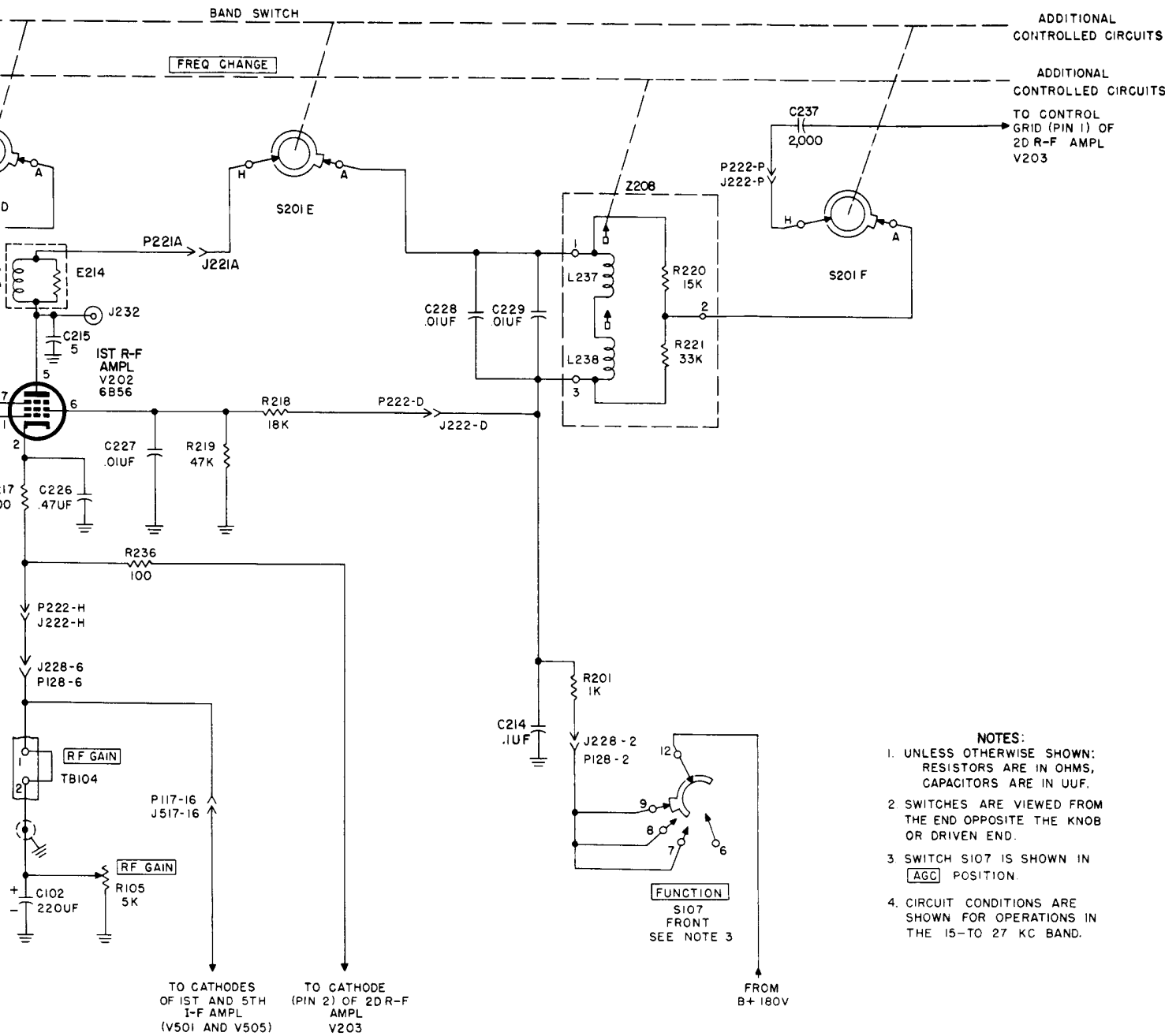

Figure 13. Antenna circuit and first rf amplifier, schematic diagram.



Unit and first rf amplifier, schematic diagram.

P222-P, and coupling capacitor C237 to the control grid of second rf amplifier V203. Tuned circuit Z208 contains two permeability-tuned coils in series, which cover the frequency range of 15 to 27 kc. Coil L237 is for tuning, and L238 is provided for alinement.

c. Jack J231 provides a connection to the grid circuit of V202 for test and alinement purposes, and J232 provides connection to the plate circuit.

d. Wafers S201E and S201F are sections of the seven-position band switch. Selection of one of the seven tuned circuits in the plate circuit of the first rf amplifier is performed by these switch sections. The frequency range of each tuned circuit (Z208 through Z214) is the same as that described in paragraph 52*e*. Each tuned circuit is permeability-tuned for resonance by rotation of the **FREQ CHANGE** control and is provided with series inductance for circuit alinement.

54. Second Rf Amplifier V203

(fig. 14)

The second rf amplifier using a miniature pentode tube, type 6BJ6, amplifies the signal voltages from the first rf amplifier.

a. When the **FUNCTION** switch is set to **AGC**, grid bias for the second rf amplifier is supplied from the agc circuit through P128-9 and J228-9, J222-N and P222-N, decoupling resistor R235 (which is bypassed by capacitor C225), and grid resistor R214. When the **FUNCTION** switch is set to the **MGC** position, the agc line is grounded and the tube bias is controlled completely by **RF GAIN** control R105 and cathode resistor R236 which provides minimum bias. To prevent degeneration, a low-impedance signal circuit from cathode to ground is provided by capacitor C238. The **RF GAIN** control is common to the first and second rf stages and to the first and fifth if. stages. The screen-grid (pin 6) potential is obtained through voltage-dropping resistor R237 from the output of the 180-volt supply through P222-L and J222-L, decoupling resistor R202, J228-2 and P128-2, and **FUNCTION** switch S107. Resistor R238 is connected from the screen grid to ground as a bleeder to minimize variations in screen voltage caused by screen-current changes. Rf signal voltages that appear on the screen are bypassed to ground through capacitor C239. Plate voltage is applied to V203 through P221-R and J221-R, S201G, primary of transformer T208 (L251 and L252), decoupling resistor R202, J228-2 and

P128-2, and **FUNCTION** switch S107. Resistor R202 and bypass capacitor C213 function as a decoupling filter to prevent rf signals in the plate circuit from entering the common B circuits. Voltage for the plate and screen circuits is applied through **FUNCTION** switch S107 in all positions except **STAND BY** and **OFF**.

b. Signals from the first rf stage are applied through S201F, J222-P and P222-P, and coupling capacitor C237 to the control grid (pin 1) of the second rf amplifier. The amplified signals which appear at the plate (pin 5) of the second rf amplifier are applied through P221-R, J221-R, and S201G to the primary winding of T208. Capacitors C240 and C241 form a resonant circuit with the primary of T208. The balanced output of the second rf stage is taken from secondary winding L253. Resistors R239 and R240 are connected across L253. The junction of resistors R239 and R240 is grounded to obtain an electrical center tap for secondary winding L253; this produces signal voltages across the resistors of equal amplitude but of 180° phase difference with respect to ground. These out-of-phase signal voltages are then applied through switch sections S201H and S201J to the grids (pin 7 and pin 2) of first mixer V204. The primary of T208 contains two permeability-tuned coils in series which cover the frequency range of 15 to 27 kc. Inductor L251 is provided for tuning, and L252 for alinement.

c. Jack J234 provides a connection to the plate circuit and J233 to the grid circuit of second rf amplifier V203 for test and alinement purposes.

d. Wafers S201G, S201H, and S201J are sections of the seven-position band switch. These switches select one of seven transformers in the plate circuit of the second rf amplifier. The frequency range of each transformer (T208 through T214) is the same as that of the antenna transformers described in paragraph 52*e*.

55. First Mixer V204

(fig. 15)

The first mixer uses a miniature dual-triode tube, type 12AT7. Signals from the second rf amplifier are applied to the control grids (pins 2 and 7); an injection voltage is applied to the cathodes (pins 3 and 8). The two signals are heterodyned in the first mixer, producing two frequencies which are equal to the sum and difference

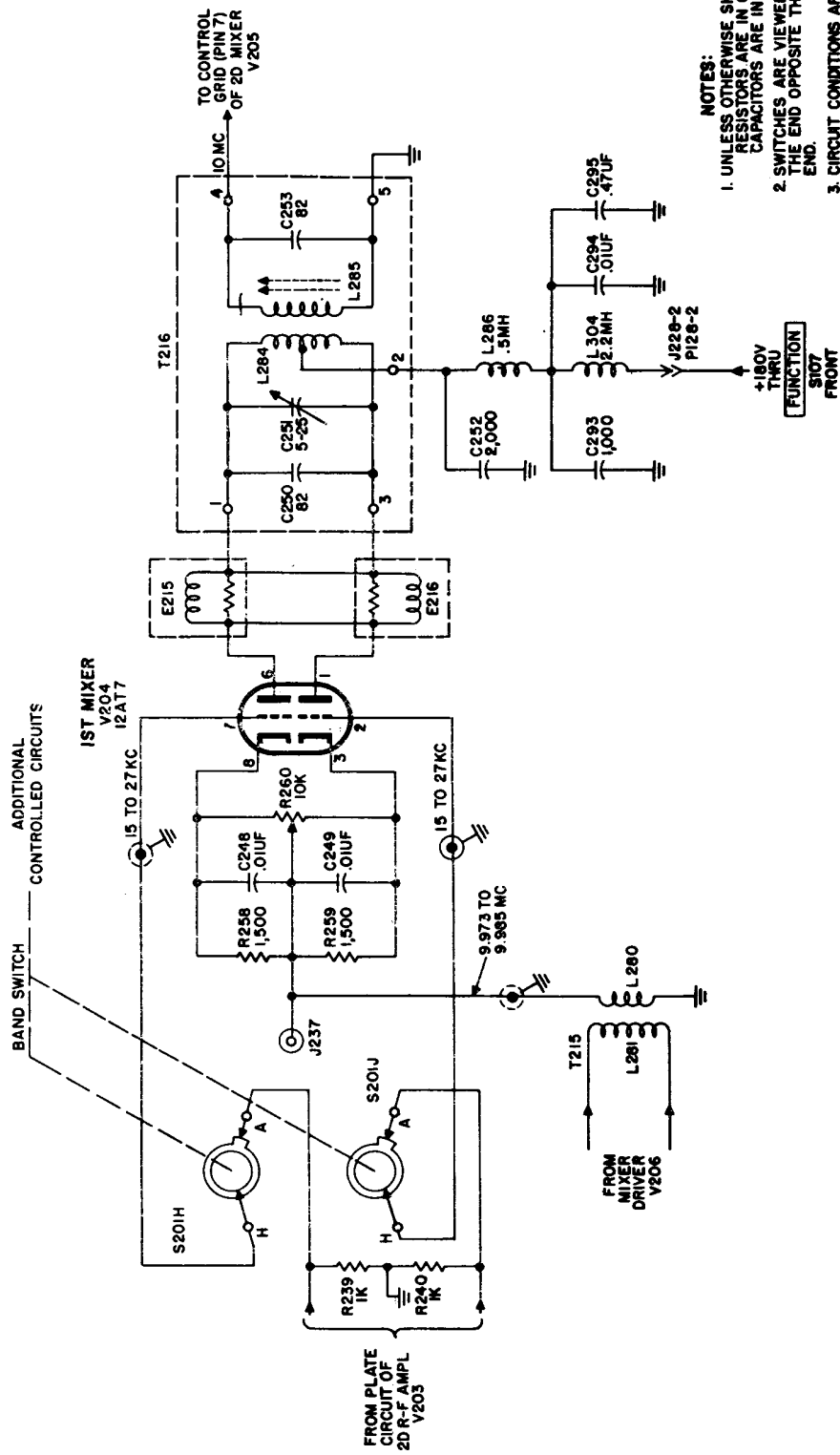

- NOTES:
1. UNLESS OTHERWISE SHOWN: RESISTORS ARE IN OHMS, CAPACITORS ARE IN UUF.
 2. SWITCHES ARE VIEWED FROM THE END OPPOSITE THE DRIVEN END.
 3. CIRCUIT CONDITIONS ARE SHOWN FOR OPERATION IN THE 15- TO 27-KC BAND.

TM 895-28

Figure 15. First mixer, schematic diagram.

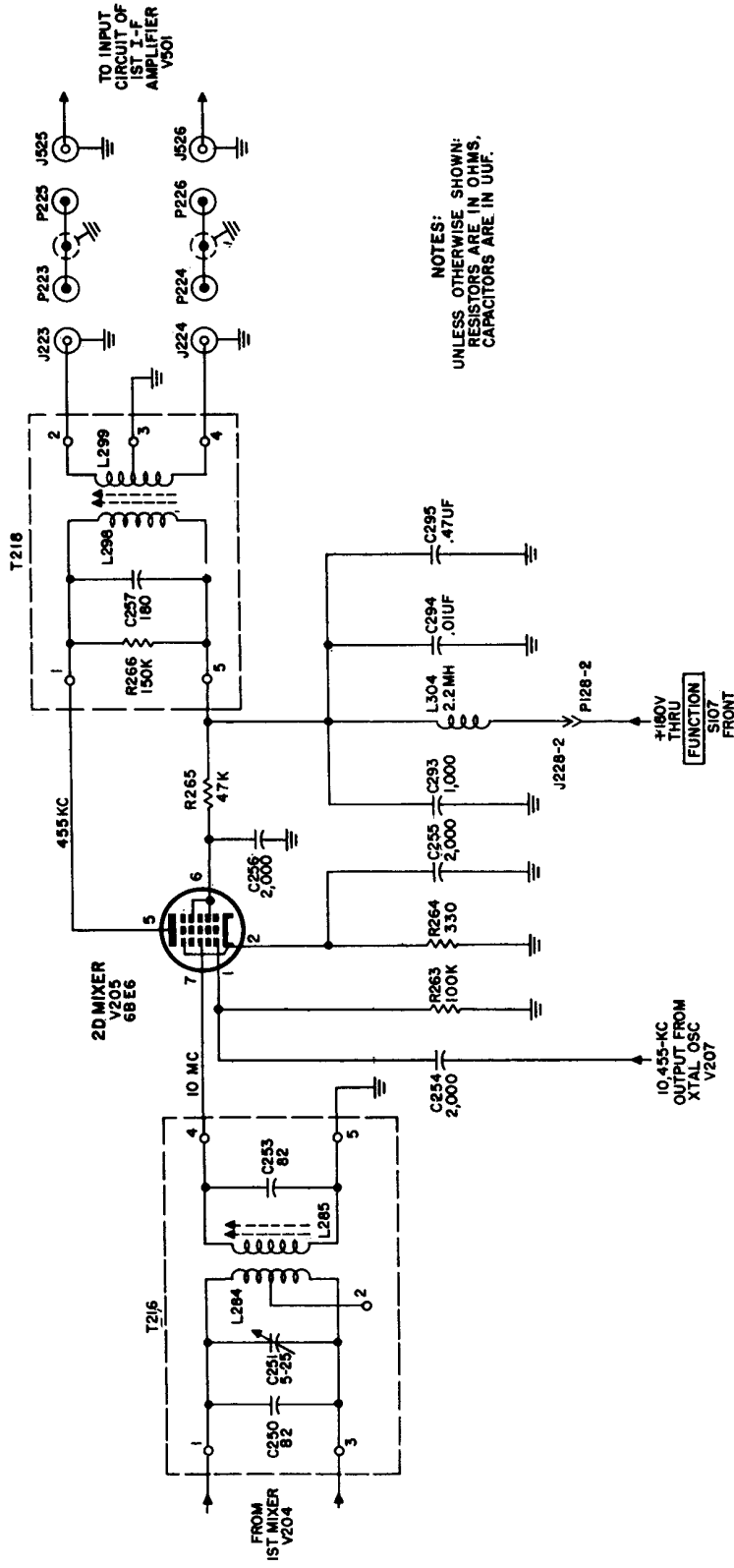

Figure 16. Second mixer, schematic diagram.

of the applied signals. The plate circuit is tuned to 10 mc, which is the sum of the applied frequencies.

a. Bias for one control grid (pin 7) is developed across the parallel combination of cathode resistor R258 and a portion of control R260. Bias for the other control grid (pin 2) is developed across the parallel combination of cathode resistor R259 and a portion of control R260. Bypass capacitors C248 and C249 prevent degeneration and provide low-impedance signal paths across cathode resistors R258 and R259, respectively. Resistors R239 and R240 (located within transformer T208) complete the dc circuits for the control grids through switch sections S201H and S201J. B voltage is applied to the plates of the first mixer through parasitic suppressors E215 and E216; one-half of L284 (primary of T216) for each plate; rf filter comprised of L286 bypassed by C252; a second rf filter comprised of L304 bypassed by capacitors C293, C294, and C295, J228-2 and P128-2; and FUNCTION switch S107. Capacitors C250 and C251, across primary winding L284 and T216, form a resonant circuit; capacitor C251 is variable for alinement purposes. Secondary winding L285 incorporates an adjustable powdered-iron core for alinement purposes; capacitor C253 completes the resonant secondary circuit. The rf filter composed of L304 and capacitors C293, C294, and C295 is common to several circuits within the receiver, and functions to prevent rf signals from entering the common B+ circuits.

b. Two signal voltages from the second rf amplifier, of equal amplitude but 180° out of phase with respect to ground, are applied through S201H and S201J to the control grids (pin 7 and pin 2) of the first mixer. The signals that appear at the plates (pin 6 and pin 1) are also out of phase in the push-pull primary winding of T216. The injection signal from mixer driver V206 (par. 66) is applied through T215 to the junction of capacitors C248 and C249 in the balanced cathode circuit of V204. The application of injection voltage to both cathodes of the first mixer produces in-phase signals at the plates. These signals at the plates oppose each other and cancel in the push-pull primary winding of T216. Because the injection voltage does not appear at the output, any noise voltages produced in the generation of the injection voltages do not appear. Control

R260 is used to provide equal injection voltages at both cathodes. Circuits that develop the injection voltages are described in paragraph 60.

c. Incoming signals, 15 to 1,500 kc, are applied to the control grids of V204. The injection voltages, 9.985 to 8.5 mc, are applied to the cathodes. The two signals are heterodyned in the stage to produce the sum and difference frequencies. The sum of the two frequencies is always 10 mc; the primary and secondary of T216 are tuned to this frequency. The 10-mc output if. is applied directly to the control grid (pin 7) of second mixer V205.

d. Jack J237 provides a connection to the cathode circuit of first mixer V204 for test and alinement purposes. Switch sections S201H and S201J are part of the seven-position band switch.

56. Second Mixer V205

(fig. 16)

The second mixer uses a miniature pentagrid converter tube, type 6BE6. The 10-mc signal from the first mixer (V204) is applied to the pin 7 control grid, while a 10,455 signal is applied to the pin 1 control grid. The plate circuit is tuned to 455 kc, which is one of the frequencies that result from the heterodyning process. It is the difference of the applied frequencies.

a. Bias for both control grids is produced by the parallel combination of R264 and C255. Additional grid leak bias for the pin 1 control grid is produced by the combination of C254 and R263, because the signal at that grid is strong enough to drive it positive during a part of each cycle, causing grid current to flow. Plate and screen grid voltages are taken from the same point that supplies V204. Resistor R265 is the screen-dropping resistor; it is bypassed by C256. Plate voltage is applied through the primary of T218 (L298) and its parallel resistor, R266. Capacitor C257 forms a resonant circuit, tuned to 455 kc, with L298. Resistor R266 increases the bandwidth of the tuned circuit.

b. Secondary winding L299 of T218 is center-tapped to provide a balanced output with respect to ground. One end of the secondary is connected by coaxial cable through J223 and P223, and P225 and J525; the other end is connected through J224 and P224, and P226 and J526. The 455-kc output signal is applied to the input circuit of first, if. amplifier V501.

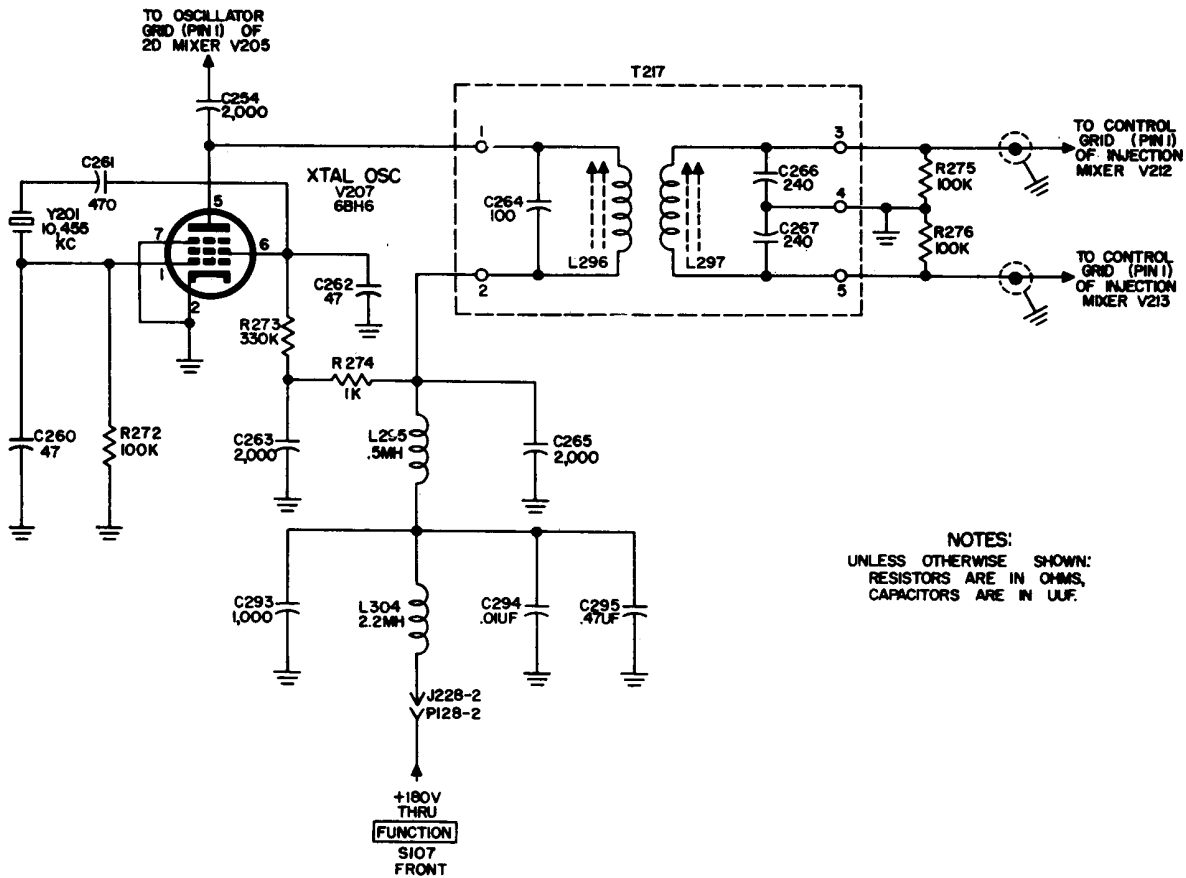

Figure 17. Crystal oscillator, schematic diagram.

TM 855-27

57. Crystal Oscillator V207

(fig. 17)

The crystal oscillator stage uses a miniature pentode tube, type 6BH6, that supplies injection voltage to second mixer V205 and to injection mixers V212 and V213.

a. Fundamentally, the circuit is an electron-coupled oscillator, with the cathode, control grid, and screen grid operating as a triode Pierce oscillator. The 10,455-kc crystal, Y201, is connected from the control grid to the screen grid through blocking capacitor C261. Resistor R272 and capacitor C260 develop grid leak bias. Resistor R273 is used as a load resistor for the oscillator circuit. Capacitor C262 completes the feedback path to the control grid through C260. Resistor R274 and capacitor C263 form a screen decoupling network. Rf choke L295 and capacitor C265 decouple the crystal oscillator stage from the other stages connected to L304, the B+ connecting point.

b. Because the plate current will vary with changes in screen current, the frequency of the plate current is the same as that of the oscillator circuit. The primary of T217, L296, and C264 form a resonant circuit in the plate circuit of V207. This resonant circuit is tuned to the same frequency as that of the crystal, 10,455 kc. An output for the second mixer is taken directly from the plate of the tube. Another output for the injection mixers is taken from the secondary of T127 (L297) which, with C266 and C267, forms a resonant circuit. The latter two capacitors are grounded at their junction to provide an output of two voltages 180° apart. These voltages are connected to the control grids of injection mixers V212 and V213 respectively. Resistors R275 and R276 are the grid resistors of the two injection mixer stages.

c. Coils L296 and L297 are provided with powdered-iron cores for alinement purposes.

58. Variable-Frequency Oscillator V701

(fig. 18)

The vfo subchassis contains vfo V701 and buffer V702. The output of the vfo is applied to the first mixer injection circuits through buffer V702 (par. 59) and phase inverter V211 and is heterodyned with the 10,455-kc signal from the crystal oscillator to produce an injection signal voltage for first mixer V204 (fig. 15). The vfo uses a miniature pentode tube, type 5749, connected in a Hartley oscillator circuit to produce a signal voltage which is applied to buffer V702.

a. Basically, the vfo is a triode, consisting of the cathode (pin 7), the control grid (pin 1), and the screen grid (pin 6). The screen grid acts as the oscillator anode. The tapped coil, L701, and the parallel capacitors C701, C702, C703, and C704, form the tuned circuit for the oscillator. Grid leak bias is produced by the combination of R701 and C706. Resistor R702 is the load resistor for the oscillator circuit. Capacitor C705 completes the rf circuit between the screen grid and ground.

b. Because plate current will vary at the same frequency as the screen current, the plate circuit is coupled to the oscillator circuit through the electron stream of the tube. Resistor R703 is the plate load resistor; the signal in the plate circuit is coupled to the buffer (V702) through C711.

c. Plate and screen voltages are taken from the decoupling filter composed of rf choke L702 and capacitor C710. These voltages are always applied to the vfo; they are independent of the position of the FUNCTION switch.

d. Tuned circuit Z701 is inclosed within a hermetically sealed can. The temperature of the tuned circuit is maintained within close tolerances by a heating element which is a coil of resistance wire wound around the shield can. The can, together with a layer of insulation, is placed inside a second can to form the oven. When the temperature at the receiver location varies over a wide range, the frequency stability of the receiver may be increased by turning OVEN switch S109 on the back panel to ON. The current through the heating element of HR701 is controlled by thermostat switch S701 to maintain a constant oven temperature of 75° C. (167° F.). Capacitor C705, connected across the contacts of S701, acts as a spark suppressor.

e. As the receiver is tuned throughout the low range of 15 to 500 kc, a powdered-iron core is moved within L701 to change the fundamental frequency of the oscillator over a range of 470 to 955 kc. Throughout the high range of 500 to 1,500 kc, the fundamental frequency of the oscillator covers the range of 477.5 to 977.5 kc. The core within L701 is moved throughout the limits of mechanical travel by a 52-turn precision screw which is coupled through a gear train to the FREQ CHANGE control (fig. 45). This oscillator is hermetically sealed and should not be opened or tampered with unless complete facilities are available for resealing.

59. Buffer V702

(fig. 18).

The buffer uses a miniature pentode tube, type 6BH6. When the FREQ RANGE switch is set to the low range position (15 to 500 kc), the buffer stage operates as a straight-through amplifier. When the FREQ RANGE switch is set to the high range position (500 to 1,500 kc), the stage operates as a frequency doubler.

a. Cathode bias is developed by the parallel combination of R705 and C712. Resistor R704 provides a direct-current path to ground for the control grid. Screen grid voltage is obtained from the same B+ point that supplies the vfo. Resistor R702 is the screen-dropping resistor; it is bypassed by capacitor C709. The plate circuit is completed through coaxial connectors P730 and J230, section B of FREQ RANGE switch S203, and either Z217 or Z218. The choice of Z217 or Z218 depends on the setting of the FREQ RANGE switch.

b. Two coils containing powdered-iron cores (L274 and L275) make up Z218. In combination with capacitors C282 and C283, Z218 forms a resonant circuit that tunes within the frequency range of 470 to 955 kc. This resonant circuit forms the plate load of the stage for the low-frequency range. Coils L272 and L273 make up Z217. For the high-frequency range, Z217, with its capacitors C282 and C283, forms the plate load. The frequency range of this combination is 955 to 1,955 kc, which is twice the range of the vfo output when the FREQ RANGE switch is set for the high range. When switch section S203B selects one tuned circuit, resistor R290 is connected in parallel with the unused circuit to

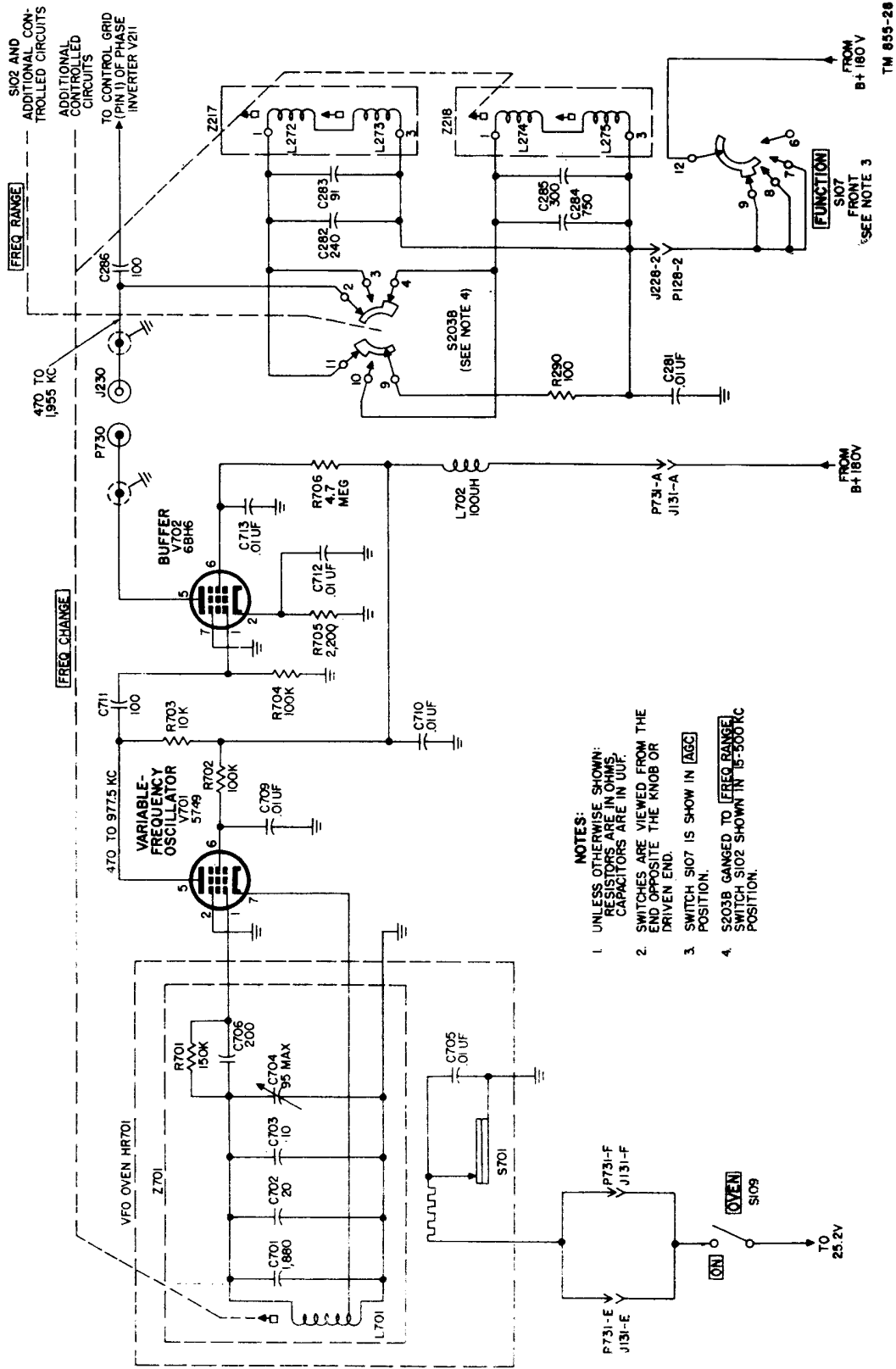

Figure 18. Vfo and buffer, schematic diagram.

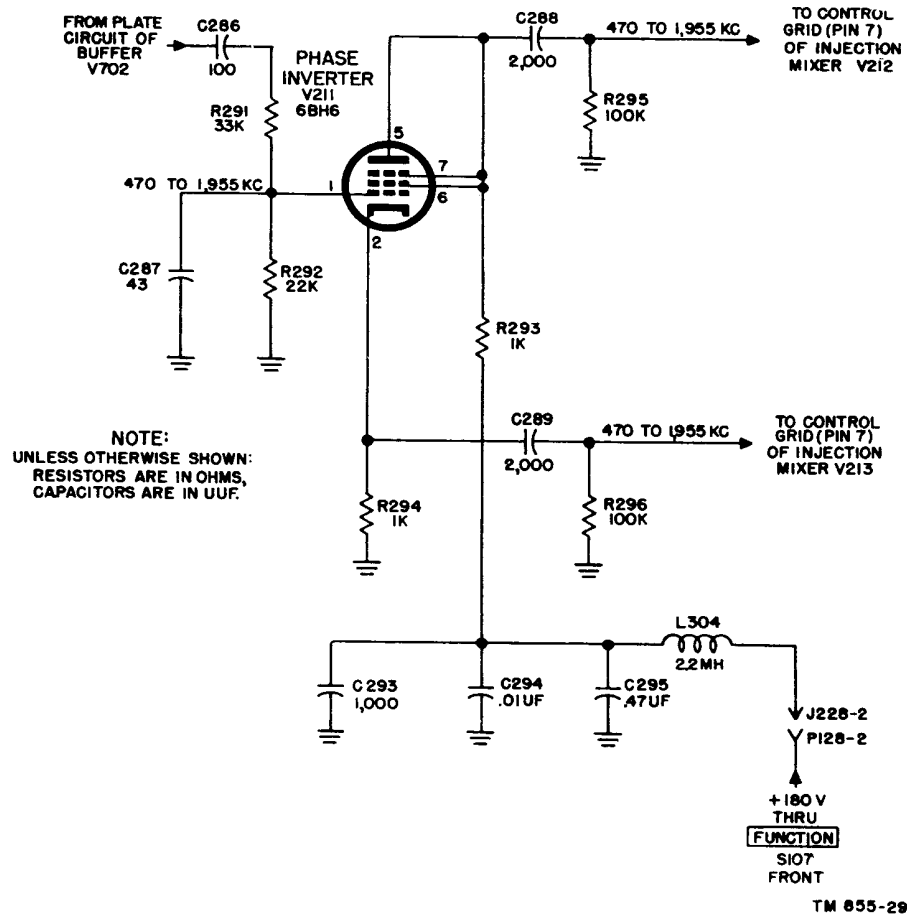

Figure 19. Phase inverter, schematic diagram.

prevent possible interaction between the two circuits.

c. The powdered-iron cores of coils L272 and L274 are tuned by the FREQ CHANGE switch; coils L273 and L275 are provided with powdered-iron cores for alignment purposes. Capacitor C281 decouples the plate circuit from the common 180-volt supply. Plate voltage is applied through J228-2, P128-2, and the FUNCTION switch.

d. Output signals of the buffer are coupled from the plate circuit through C286 to the control grid of phase inverter V211.

60. First-mixer Injection Circuits

The first-mixer injection system consists of the following stages: phase inverter V211, injection mixers V212 and V213, input coupler V208, output coupler V209, and mixer driver V206. The system functions to heterodyne the variable output of the buffer with that of the 10,455-kc crystal os-

cillator to produce an injection signal for use in the first-mixer stage. The system used in the first-mixer injection circuits allows for a small deviation in crystal-oscillator frequency. Low-pass filter FL201 attenuates all frequencies above 10 mc and allows signal voltages generated by the injection mixers (V212 and V213) below 10 mc to be amplified for use as first-mixer injection voltage.

61. Phase Inverter V211

(fig. 19)

The phase inverter uses a miniature pentode tube, type 6BH6, connected as a triode. Signal voltages taken from buffer V702 are applied to the phase inverter and divided into output voltages with a 180° phase difference for application to injection mixers V212 and V213.

a. Signals from buffer V702 are applied through coupling capacitor C286 and resistor R291 to the

control grid (pin 1) of the phase inverter. Resistors R291 and R292 act as a voltage-divider network for the signal voltage, with the junction of the resistors connected to the control grid. Grid leak bias is developed by C287 and R292. The load circuit for the tube consists of two resistors: R294 in the cathode circuit and R293 in the plate circuit. Signal voltages at the control grid (pin 1) are reproduced in the same phase in the cathode circuit across cathode-load resistor R294, while signal voltages 180° out of phase are developed across plate-load resistor R293. Signal voltage from the plate (pin 5) is applied through coupling capacitor C288 to the control grid (pin 7) of injection mixer V212; signal voltage from the cathode (pin 2) is applied through coupling capacitor C289 to the control grid (pin 7) of injection mixer V213. Thus, signal voltages from the phase inverter appearing at the control grids of injection mixers V212 and V213 are of equal amplitude but differ in phase by 180° and assume a push-pull relationship.

b. The screen grid (pin 6), suppressor grid (pin 7), and plate (pin 5) are connected together so that the tube functions as a triode. Plate potential is obtained from the FUNCTION switch through plate-load resistor R293 and, rf filter L304 (bypassed by C293, C294, and C295).

62. Injection Mixers V212 and V213

(fig. 20)

The injection mixer circuit uses two miniature pentagrid converter tubes, type 6BE6, in a balanced mixer circuit. A signal in the frequency range of 470 to 1,955 kc from phase inverter V211 is applied to the push-pull control grids (pins 7), while an injection voltage of 10,455 kc is applied to the push-pull grids (pin 1). The two signals are heterodyned in the injection mixers to produce a difference frequency in the range of 8.5 to 9.985 mc, supplied through the remaining first-mixer injection circuits as injection voltage for first mixer V204.

a. Bias for the control grid (pin 7) and the oscillator grid of V213 is developed across R298. Bypass capacitors C290 and C291, connected across cathode resistors R297 and R298, respectively, prevent degeneration and provide low-impedance signal paths for the input- and output-signal frequencies. Resistor R295, connected from the control grid (pin 7) of V212 to ground, completes the dc grid return circuit, and R296 completes the dc

grid return circuit for V213. Resistor R275, connected from the oscillator grid (pin 1) of V212 to ground, completes the dc grid return circuit, and R276 completes the dc grid return circuit for V213. The screen-grid (pin 6) potential for both V212 and V213 is obtained from the 180-volt supply through voltage-dropping resistor R299, rf filter L304 (bypassed by C293, C294, and C295), J228-2 and P128-2, and FUNCTION switch S107. Rf signal voltages that appear on the screens of both injection mixers are bypassed to ground through capacitor C292. B voltage is applied to the parallel plates (pins 5) of the injection mixers through the contacts of S203A, L300 and L301 of Z219, J228-2 and P128-2, and FUNCTION switch S107. Rf filter L304 prevents signals which are induced in the wiring from entering the common B+ circuits.

b. Signal voltages in the range of 470 to 1,955 kc, of equal amplitude but 180° out of phase with respect to ground, are taken from the plate and cathode of phase inverter V211 and are applied to the control grids (pins 7) of injection mixers V212 and V213. Signal voltage from the plate (pin 5) of the phase inverter is applied through coupling capacitor C288 to the control grid (pin 7) of injection mixer V212; signal voltage from the cathode (pin 2) is applied through coupling capacitor C289 to the control grid (pin 7) of injection mixer V213. The application of out-of-phase signal voltages at the control grids (pin 7) of the injection mixers produces opposing out-of-phase voltages at the plates (pins 5) and, because the plates are connected in parallel, these signals cancel each other. A 10,455-kc injection voltage from the push-pull output circuit of crystal oscillator V207 is applied to the oscillator grids (pins 1) of injection mixers V212 and V213. This injection voltage is 180° out of phase at each oscillator grid with respect to ground, and the two grid voltages are therefore canceled in the plate circuit. Signals in the range of 470 to 1,955 kc applied to the control grids are heterodyned with the 10,455-kc injection voltage at the oscillator grids to produce a 9.985- to 8.5-megacycles (mc) difference frequency in the plate circuit for use as first-mixer injection voltage. These signals are applied through the contacts of S203A to either tuned circuit, Z219 or Z220, depending on the switch position. Tuned circuit Z219 contains two permeability-tuned coils in series which cover the frequency range of 9.5 to 9.985 mc. Inductor

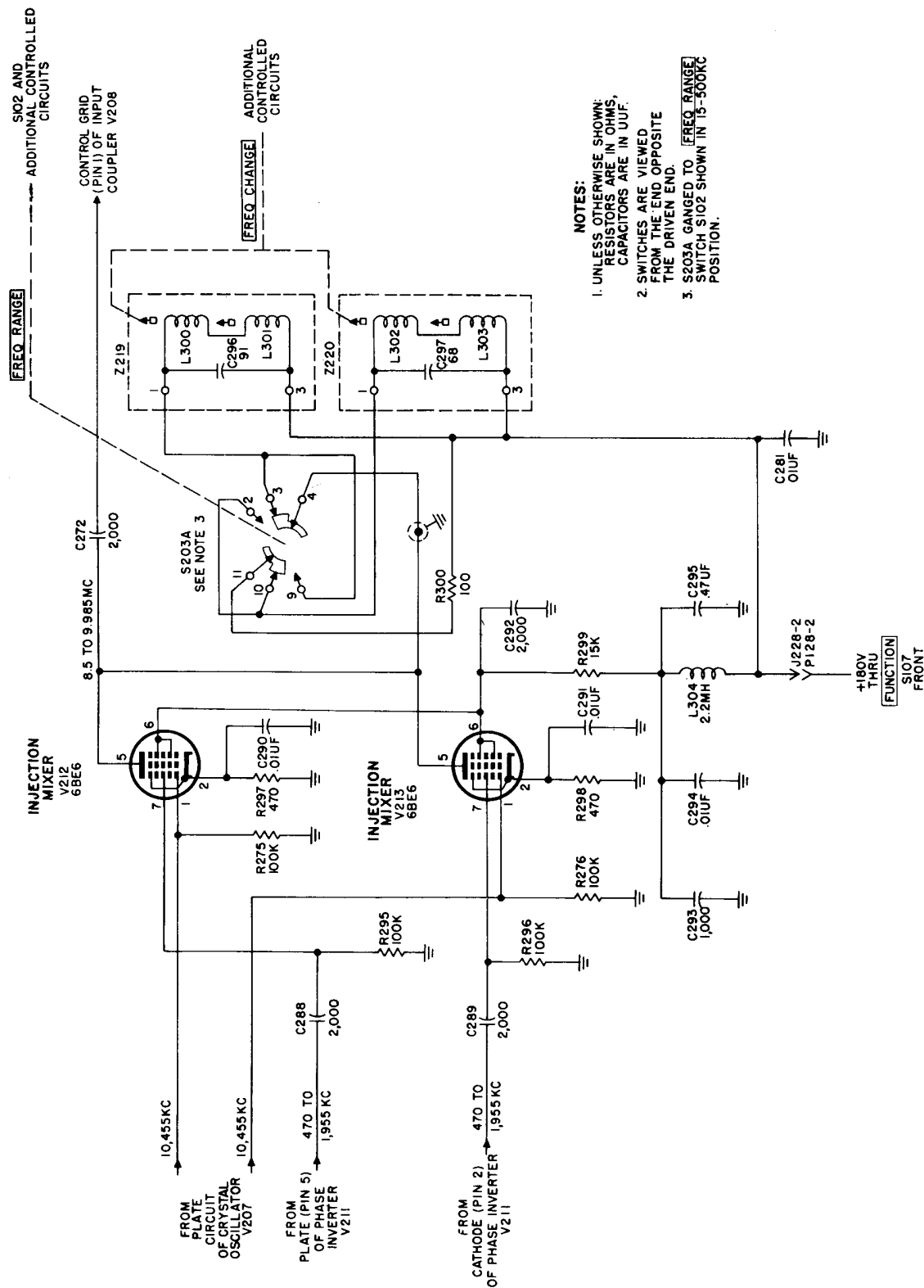

Figure 20. Injection mixers, schematic diagram.

L300 is provided for tuning, and L301 for alignment. Capacitor C296 completes the resonant circuit of Z219. Tuned circuit Z220 contains two permeability-tuned coils in series which cover the frequency range of 8.5 to 9.5 mc. Inductor L302 is for tuning, and L303 is for alignment. Capacitor C297 completes the resonant circuit of Z220. Bypass capacitor C281 provides a low-impedance rf path for signals in the injection-mixer plate circuit and decouples the plate circuit from the common B+ circuits. As the receiver is tuned throughout the low range of 15 to 500 kc, tuned circuit Z219 is selected by S203A, and the injection-mixer output frequency is 9.985 to 9.5 mc. As the receiver is tuned throughout the high range of 500 to 1,500 kc, tuned circuit Z220 is selected by S203A, and the injection-mixer output frequency is 9.5 to 8.5 mc. When S203A selects one tuned circuit (Z219 or Z220), resistor R300 is shunted across the unused tuned circuit to prevent spurious responses and possible interaction between the two tuned circuits. Injection-mixer output signals in the range of 8.5 to 9.985 mc are taken from the parallel plates through coupling capacitor C272 for application to the control grid (pin 1) of input coupler V208.

63. Input Coupler V208

(fig. 21)

The input coupler uses a miniature pentode tube, type 6BH6, connected as a triode. It operates as a cathode follower to match the input impedance of low-pass filter FL201.

a. Signals from the plate circuit of injection mixers V212 and V213 are applied through coupling capacitor C272 to the control grid of the input coupler. Signal voltage is developed between the cathode (pin 2) and ground across cathode-load resistors R280 and R281 in series. The output signal voltage from the cathode is applied through coupling capacitor C274 to the 200-ohm input of low-pass filter FL201.

b. Bias for the control grid (pin 1) is developed across cathode-load resistor R280. Output signal voltage is developed across cathode-load resistors R280 and R281 in series. Resistors R278 and R279, in series, complete the dc grid return circuit to the junction of cathode-load resistors R280 and R281. Resistor R279 and capacitor C273 form a decoupling filter to remove signal voltages in the cathode circuit from the control grid. The screen grid (pin 6), suppressor grid (pin 7), and

plate (pin 5) are connected together so that the tube functions as a triode. Plate potential is obtained from the output of the 180-volt supply through parasitic suppressor R282, rf filter L304 (bypassed by C293, C294, and C295), J228-2 and P128-2, and FUNCTION switch S107.

64. Low-Pass Filter FL201

(fig. 21)

The low-pass filter attenuates all frequencies above the cutoff frequency of 10 mc and prevents them from reaching the first mixer as injection voltage. Frequencies below 10 mc are passed by the filter with very little attenuation. The filter provides maximum attenuation at a frequency of 10,455 kc and eliminates any possible interference from the crystal-oscillator stage that may not have been canceled in the injection mixers. Low-pass filter FL201 is composed of coils L288, L290, and L292, together with series-connected branches of L287 and C275, L289 and C276, L291 and C277, and L293 and C278. Frequencies in the range of 8.5 to 9.985 mc are taken from the cathode circuit of input coupler V208 and are applied through the low-pass filter to the cathode circuit of output coupler V209. Input coupler V208 is operated as a cathode follower, and output coupler V209 is operated as a grounded-grid amplifier; thus, the filter is matched at the input and output terminations.

65. Output Coupler V209

(fig. 21)

The output coupler uses a miniature pentode tube, type 6BH6, connected as a grounded-grid amplifier. The output of low-pass filter FL201 is connected to the cathode circuit which provides the necessary low-impedance termination for the filter. The output coupler amplifies signals in the range of 8.5 to 9.985 mc for application to the control grid (pin 1) of mixer driver V206.

a. Signals from the cathode circuit of input coupler V208 are applied through low-pass filter FL201 to the cathode (pin 2) of the output coupler. Signal voltage is developed between the cathode and ground across R284 and R285. Because the control grid is at rf ground potential through C279, the signal voltage across R284 and R285 is between the cathode and the control grid (ground). The amplified signals appearing at the plate are applied through the contacts of S203C to either tuned circuit, Z215 or Z216, de-

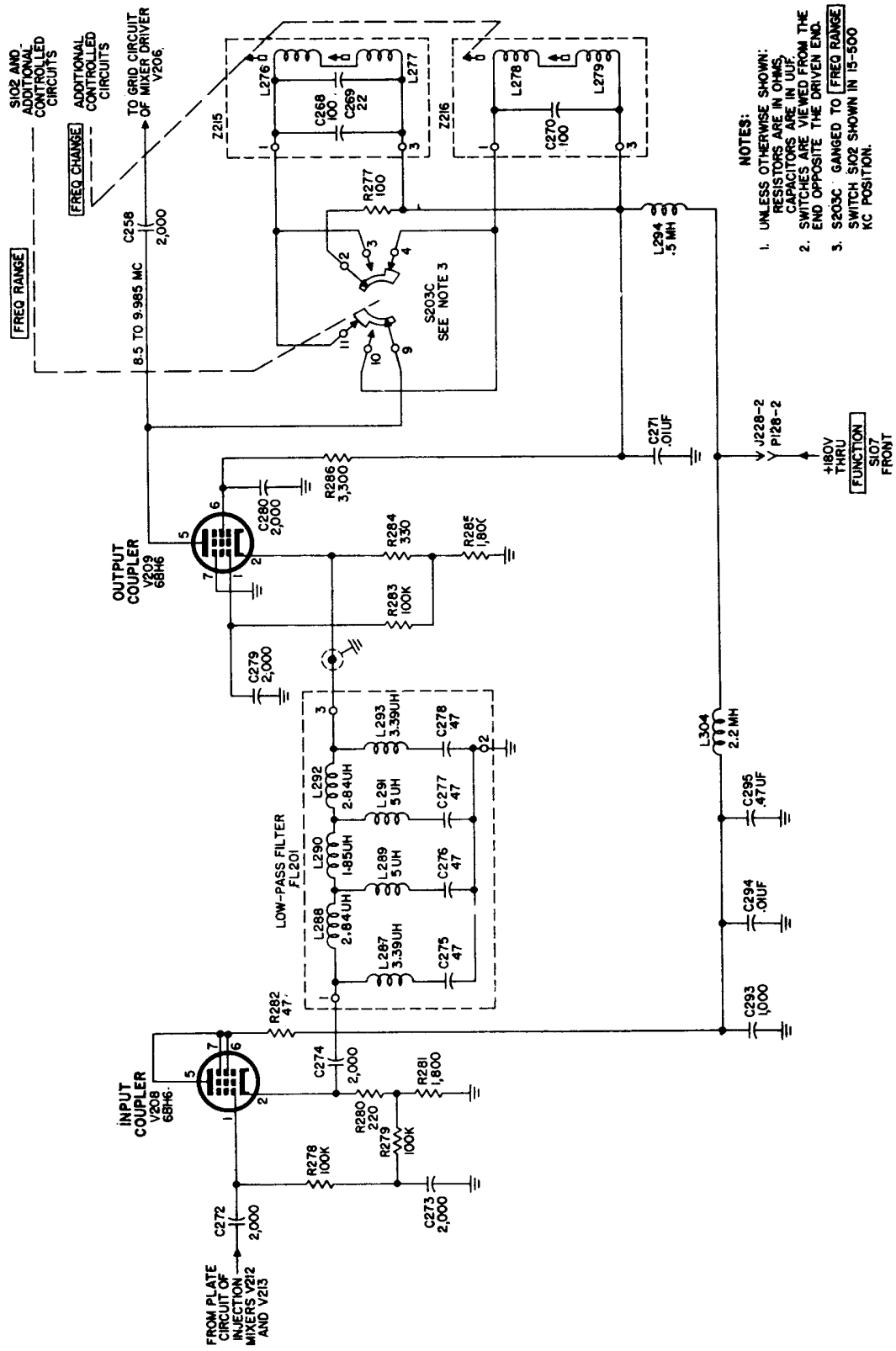

TM 885-31

Figure 21. Input coupler, low-pass filter, and output coupler, schematic diagram.

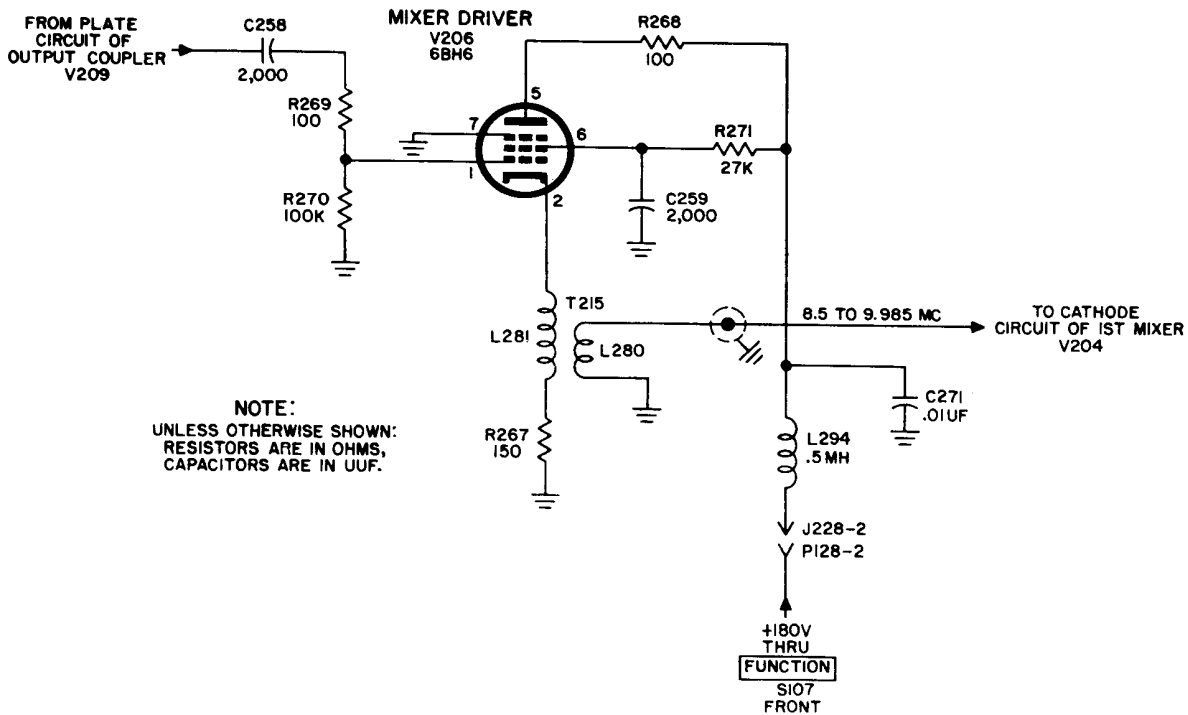

TM 855-32

Figure 22. Mixer driver, schematic diagram.

pending on the switch position. Tuned circuit Z215 contains two permeability-tuned coils in series which cover the frequency range of 9.5 to 9.985 mc. Inductor L276 is for tuning, and L277 is for alinement. Capacitors C268 and C269 complete the resonant circuit of Z215. Tuned circuit Z216 contains two permeability-tuned coils in series which cover the frequency range of 8.5 to 9.5 mc. Coil L278 is for tuning, and L279 is for alinement. Capacitor C270 completes the resonant circuit of Z216. Bypass capacitor C271, together with rf filter L294, decouples the plate circuit from the common B+ circuits. When S203C selects one tuned circuit (Z215 or Z216), resistor R277 is shunted across the unused tuned circuit to prevent possible interaction between the two tuned circuits. Signals in the range of 8.5 to 9.985 mc are taken from the plate of the output coupler through coupling capacitor C258 for application to the control grid (pin 1) of mixer driver V206.

b. Bias for the control grid (pin 1) is developed across cathode resistor R284. Resistor R283 completes the dc grid return circuit to the junction of resistors R284 and R285. Bypass capacitor C279,

connected from the control grid to ground, places the control grid at rf ground potential. Screen-grid (pin 6) potential is obtained from the same point that supplies the plate. Resistor R286 is a screen-dropping resistor; it is bypassed by C280.

66. Mixer Driver V206

(fig. 22)

The mixer driver uses a miniature pentode tube, type 6BH6, connected as a cathode follower. Signal voltage in the frequency range of 8.5 to 9.985 mc, taken from the plate circuit of output coupler V209, is applied to the control grid (pin 1) of the mixer driver that supplies injection voltage to the low-impedance-cathode input circuit of first mixer V204.

a. Signals from the plate circuit of output coupler V209 are applied through coupling capacitor C258 and parasitic suppressor resistor R269 to the control grid of the mixer driver. Signal voltage is developed between the cathode (pin 2) and ground across primary winding L281 of transformer T215 and cathode resistor R267 in series. Signals in the range of 8.5 to 9.985 mc are taken from secondary winding L280 of trans-

former T215 for application as injection voltage to the balanced, low-impedance cathode circuit of first mixer V204.

b. Bias for the control grid is developed across cathode resistor R267. Resistor R270, connected from the control grid to ground, completes the dc grid return circuit. Screen-grid and plate voltages are taken from the decoupling filter L294 and C271. Resistor R271 is a screen-dropping resistor; it is bypassed by C259.

67. Crystal Filter

(fig. 23)

To distinguish between adjacent signals and to prevent interference from signals of a frequency close to that of the desired carrier, a pass band as narrow as 100 cps in the 455-kc if. amplifier may be required. Crystal filter Z501 provides the filtering action necessary to establish the two narrow pass bands of .1 and 1 kc. It is a part of the bandwidth control system that provides the required degree of selectivity for the receiver.

a. The output of the second-mixer stage is coupled by transformer T218, through J223 and P223, P225 and J525, J224 and P224, and P226 and J526, to crystal filter Z501. When IF. BANDWIDTH switch S501 is set to the .1 KC or 1 KC position, the 455-kc signal is applied to Z501; on the remaining positions of the control, marked 2 KC, 4 KC, and 8 KC, the signal is applied to the control grid (pin 1) of V501 through coupling capacitor C503. Note that with the switch in any of the last four positions, C503 short circuits crystal Y501, but, in the first position, C503 serves as a low-impedance connection at the if. to resistor R561.

b. The crystal is cut for a frequency of 455 kc. The circuit consists basically of one-half of secondary L299 (between terminals 2 and 3), crystal Y501, resistors R502 and R561, and capacitor C502.

c. The inductance and capacitance are used primarily to tune out, or cancel, the effects of capacitance found in the grid circuit of first if. tube V501, the wiring, and the adjacent component parts. This is done to reduce the crystal load circuit to one that is essentially resistive and thus prevent the crystal from tending to resonate. A variable neutralizing capacitor is connected between one end of the crystal holder for Y501 and the other half of secondary L299 (terminals 3

and 4). This capacitor feeds a voltage whose amplitude is equal, and whose phase is opposite, to that of the voltage applied from receptacle J525 across the crystal-holder capacitance to the control grid of V501, from receptacle J526. This out-of-phase voltage effectively neutralizes the capacitance of the crystal holder.

d. With the IF. BANDWIDTH switch set to the .1 KC position, the crystal is loaded principally by R502 and C502, but R561 is shunted across R502 through C503. This reduces the total resistance in the circuit; the resistance-capacitance (rc) combination, which represents the crystal series load, becomes essentially capacitive, and the crystal tunes more sharply to resonance. With the IF. BANDWIDTH switch set to the 1 KC position, the crystal is loaded principally by R502 and C502, and R561 is removed from the circuit. Since this rc combination becomes more resistive, the circuit Q is lowered, and the width of the pass band is increased. The ratio between the crystal impedance and the resistive load (1 KC position), and between the crystal impedance and the capacitive load (.1 KC position) is to maintain the same gain in the circuit in each case.

68. If. Amplifier, 455-kc

The if. amplifier system consists of six voltage-amplifier stages. The gain of the if. amplifier is controlled manually by the RF GAIN control when the FUNCTION switch is set to MGC. The gain is controlled automatically by the agc circuits when the FUNCTION switch is set to the AGC or SQUELCH position. When six amplifier stages using the same power supply are tuned to approximately the same frequency (as is the case in this amplifier), oscillations may occur as a result of coupling between the stages through the common impedance of the power supply. To prevent this, decoupling networks are used in the grid and plate circuits of all if. amplifier stages. Additional filtering is provided in the 180-volt power-supply circuit. In addition to the selectivity obtained by the use of crystal filter Z501, three of four available degrees of selectivity are obtainable by varying the coupling between the primary and secondary windings of each of the if. transformers by means of the IF. BANDWIDTH switch. The fourth degree of selectivity (16 kc) obtained in this manner is not used in the operation of Radio Receiver R-389/URR.

69. First If. Amplifier V501

(fig. 23)

The first if. amplifier stage uses a miniature pentode tube, type 6BJ6, as a voltage amplifier of 455-kc signals.

a. The control-grid circuit of V501 consists of the winding (L) in crystal filter Z501 and decoupling resistor R501 which is bypassed by C501. Resistor R501 is connected to the agc circuit through terminals 4 and 3 of TB104 and the rear section of FUNCTION switch S107. Voltage from the agc circuit is applied to terminal 3 of TB104 which, for normal operation, is connected to terminal 4 by a jumper. In the MGC position of the FUNCTION switch, the agc voltage is grounded. Under this condition, the gain of the stage is controlled by the value of the cathode bias which is established by the setting of RF GAIN control R105. Minimum bias is furnished by R503. Capacitor C505 bypasses the cathode to ground. Capacitor C504 and inductor L501 form a low-pass filter that is used to prevent interference of signals between this and other stages which use the common RF GAIN control. Capacitor C102 provides a low-impedance path to ground at rf and if., resulting in a steady dc voltage. External control of rf gain can be obtained by removal of the jumper between terminals 1 and 2 of TB104 and connecting a 5,000-ohm potentiometer between terminal 1 and ground. In the AGC position of the FUNCTION switch, the voltage from the agc circuit is applied to the control grid and the gain of the stage is controlled automatically by the average signal level. The RF GAIN control is still effective under these conditions. Screen-grid voltage is taken from the junction of R504 and R505 which, with GAIN ADJ control R562, form a voltage divider across the 180-volt supply. The screen is bypassed by C506. The plate circuit is completed to B+ through the primary of T501 and decoupling resistor R506 which is bypassed by C507. Additional filtering of the supply voltage is supplied by L503 and capacitors C530 and C531, a pi-type filter that prevents rf signals from entering the power-supply circuits. The resistor connected across the primary of T501 is used to produce the required band-pass characteristics for this stage.

b. The 455-kc if. signal from second mixer V205 is fed to the control grid of V501 either through crystal filter Z501 or directly through the contacts of IF. BANDWIDTH switch S501 and

coupling capacitor C503. The amplified signal at the plate is coupled by T501 to the control grid of second if. amplifier V502.

c. Three degrees of selectivity are obtainable by connecting one of three windings in transformer T501, through the contacts of IF. BANDWIDTH switch S502. Two of these windings have a series resistor (R507 and R508). These windings and resistors contribute to the final selectivity of the if. amplifier system. They are discussed in more detail in paragraph 74.

70. Second If. Amplifier V502

(fig. 23)

The second if. amplifier stage uses a miniature pentode tube, type 6BJ6, as a voltage amplifier.

a. The control grid (pin 1) returns to ground through a portion of the secondary winding of T501. Bias is obtained in the cathode (pin 2) circuit by plate current flowing through resistors R510 and R562. Current through GAIN ADJ control R562 is made up of the plate current through V502 and the bleeder current through R504 and R505 (par. 69*a*). Capacitor C509 is the cathode bypass capacitor which is used to prevent degeneration in the cathode circuit. The gain of the stage is preset by a screwdriver adjustment of R562 during alinement procedure. The screen grid is bypassed to ground by C510 and is connected to B+ through dropping resistor R512 to the pi-type filter described in the discussion of V501 (par. 69). The plate circuit is completed to B+ through the primary of T502, decoupling resistor R513 (which is bypassed by C511), and the filter.

b. The output of the first if. amplifier is applied through T501 to the grid of the second if. amplifier. The signal is amplified and applied to the third if. amplifier stage through T502.

c. Four degrees of selectivity can be chosen by connecting one of four windings in transformer T502, through the contacts of IF. BANDWIDTH switch S503. Two of these windings have a series resistor (R514 and R515). These windings and resistors contribute to the final selectivity of the if. amplifier system.

71. Third and Fourth If. Amplifiers V503 and V504

(fig. 24)

The third and fourth if. amplifier stages use miniature pentode tubes type 6BJ6. Their opera-

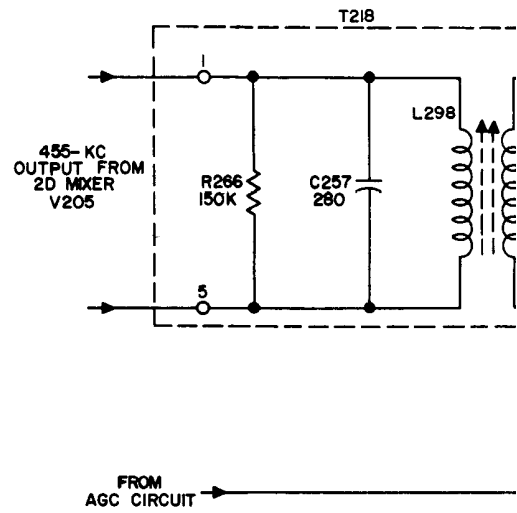

FUNCTION
S107
REAR
SEE NOTI

1. UNLESS ()
RESISTOR
CAPACITOR
2. SWITCHES
THE END
3. R561 SE
OF VALUE
4. SWITCH
POSITION.

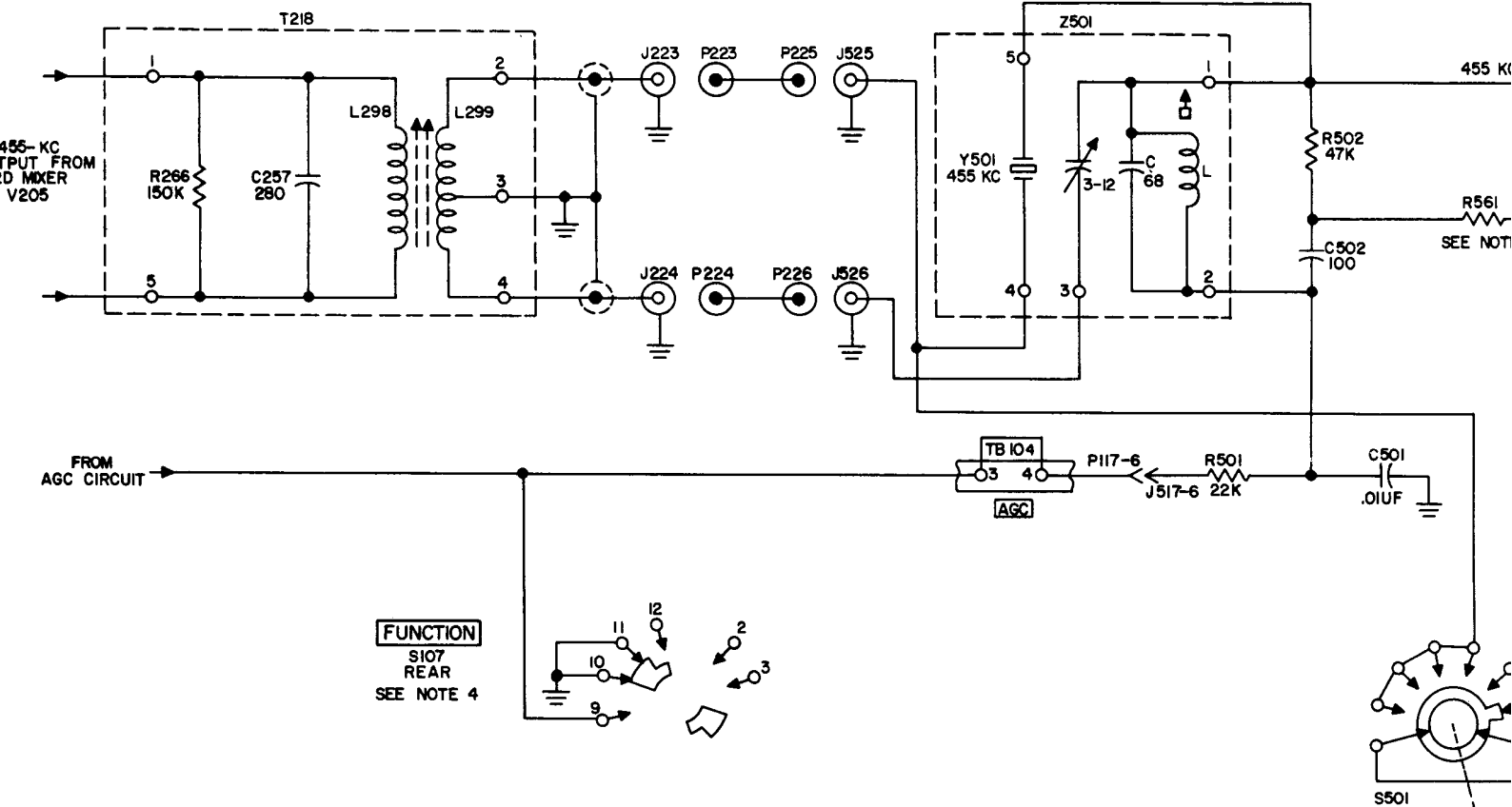

- NOTES:**
1. UNLESS OTHERWISE SHOWN:
RESISTORS ARE IN OHMS,
CAPACITORS ARE IN UUF.
 2. SWITCHES ARE VIEWED FROM
THE END OPPOSITE THE KNOB.
 3. R561 SELECTED AT TEST-RANGE
OF VALUES 560 TO 5,600 OHMS.
 4. SWITCH S107 SHOWN IN **AGC**
POSITION.

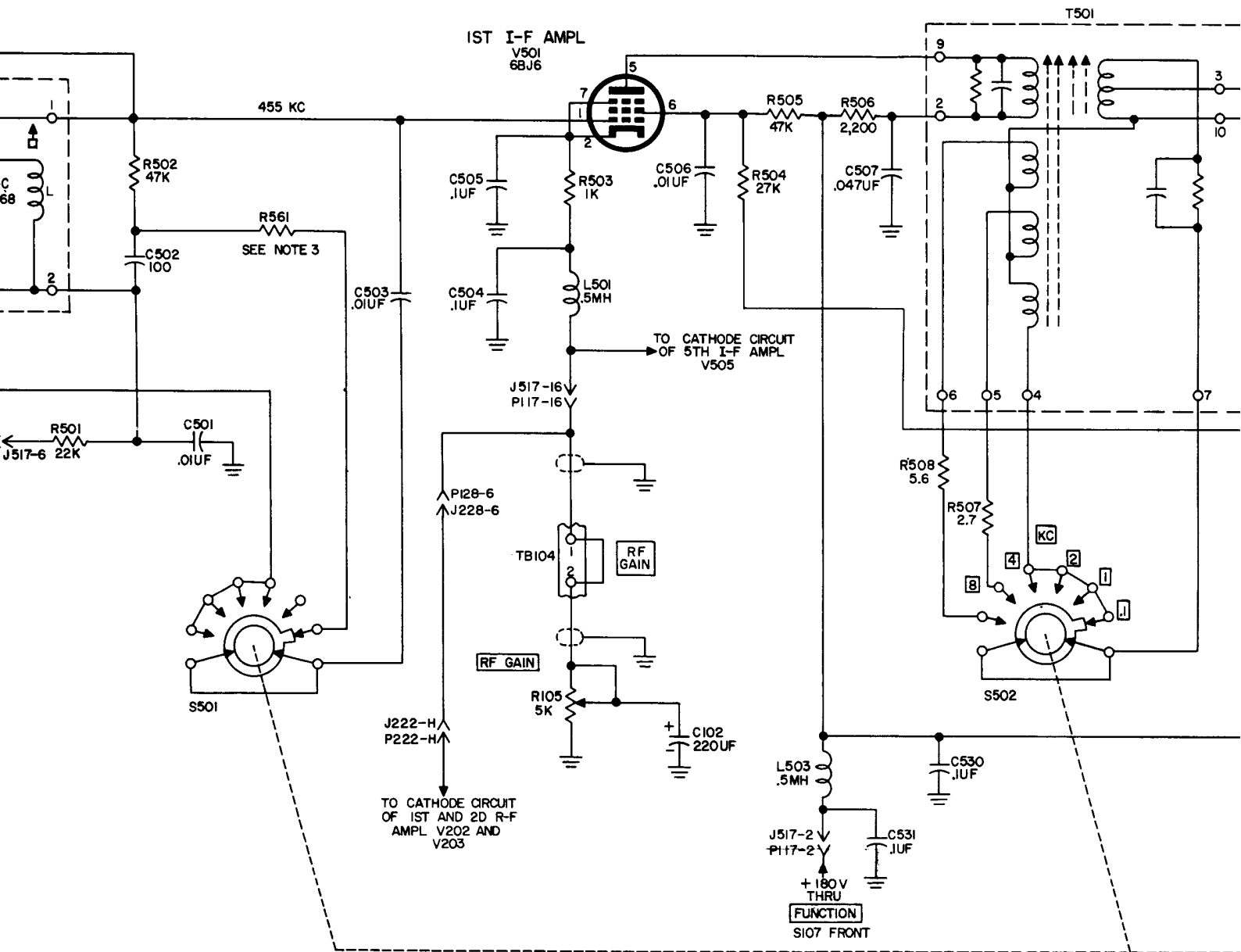
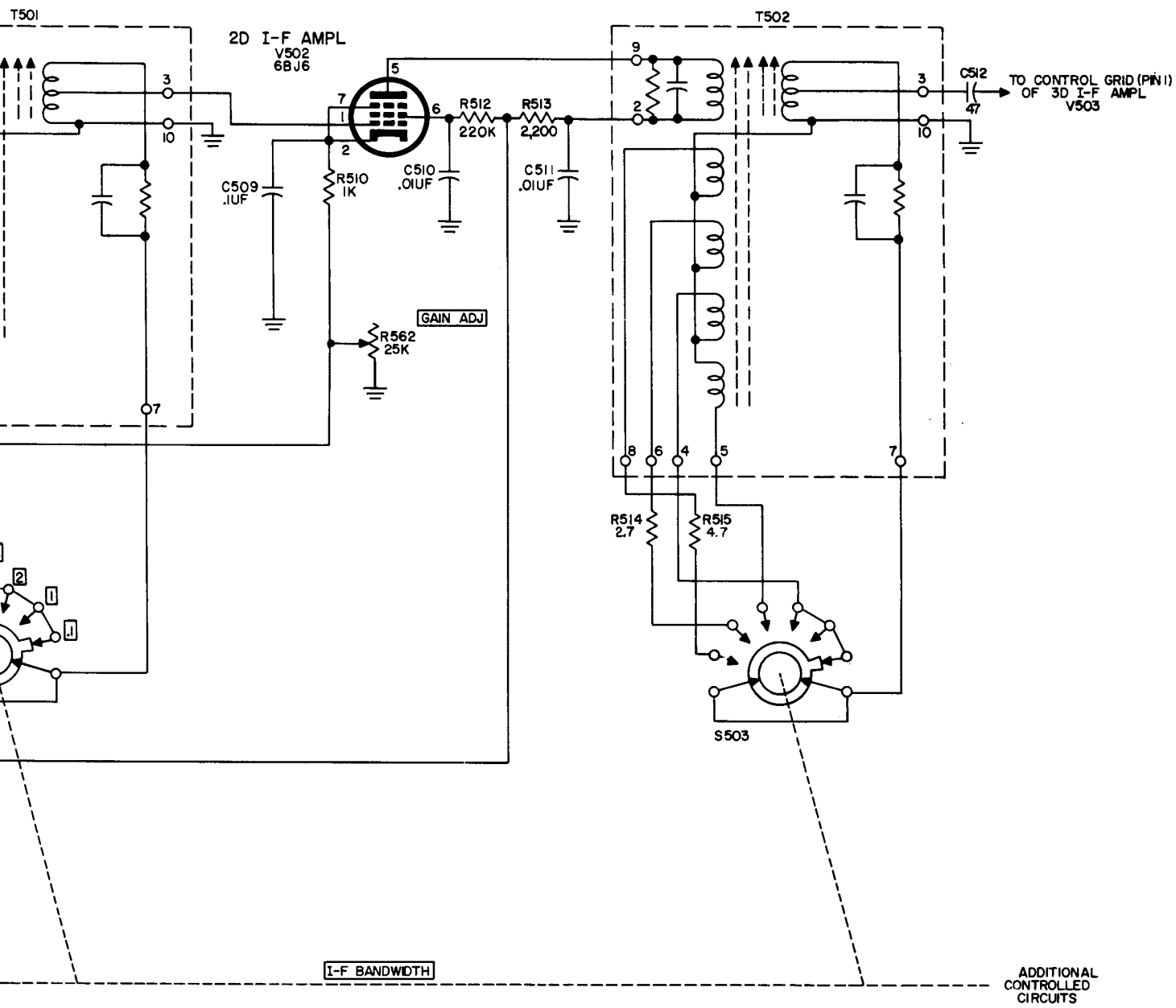

Figure 23. Crystal filter and first and second i-f. amplifiers, schematic diagram.



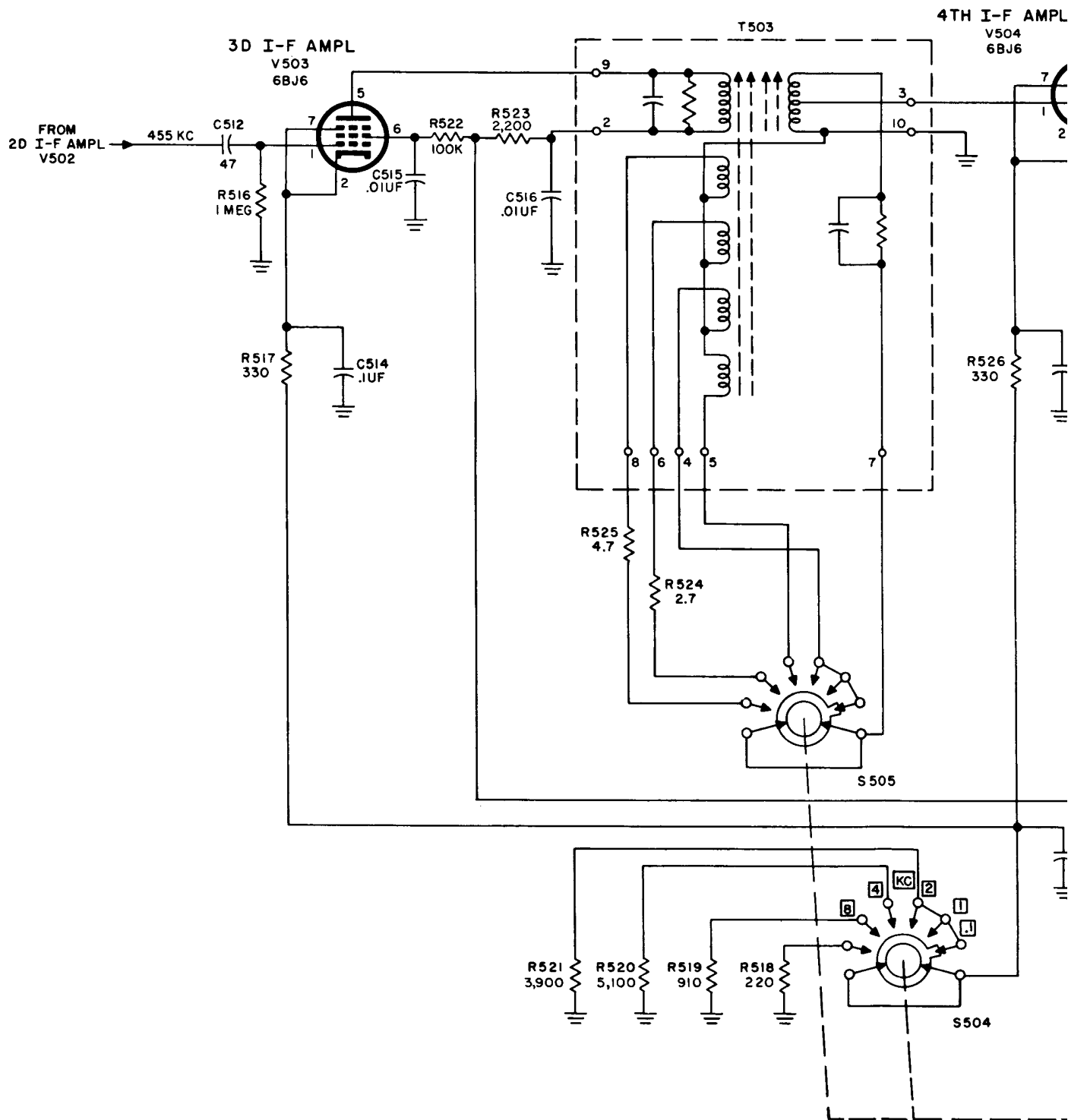
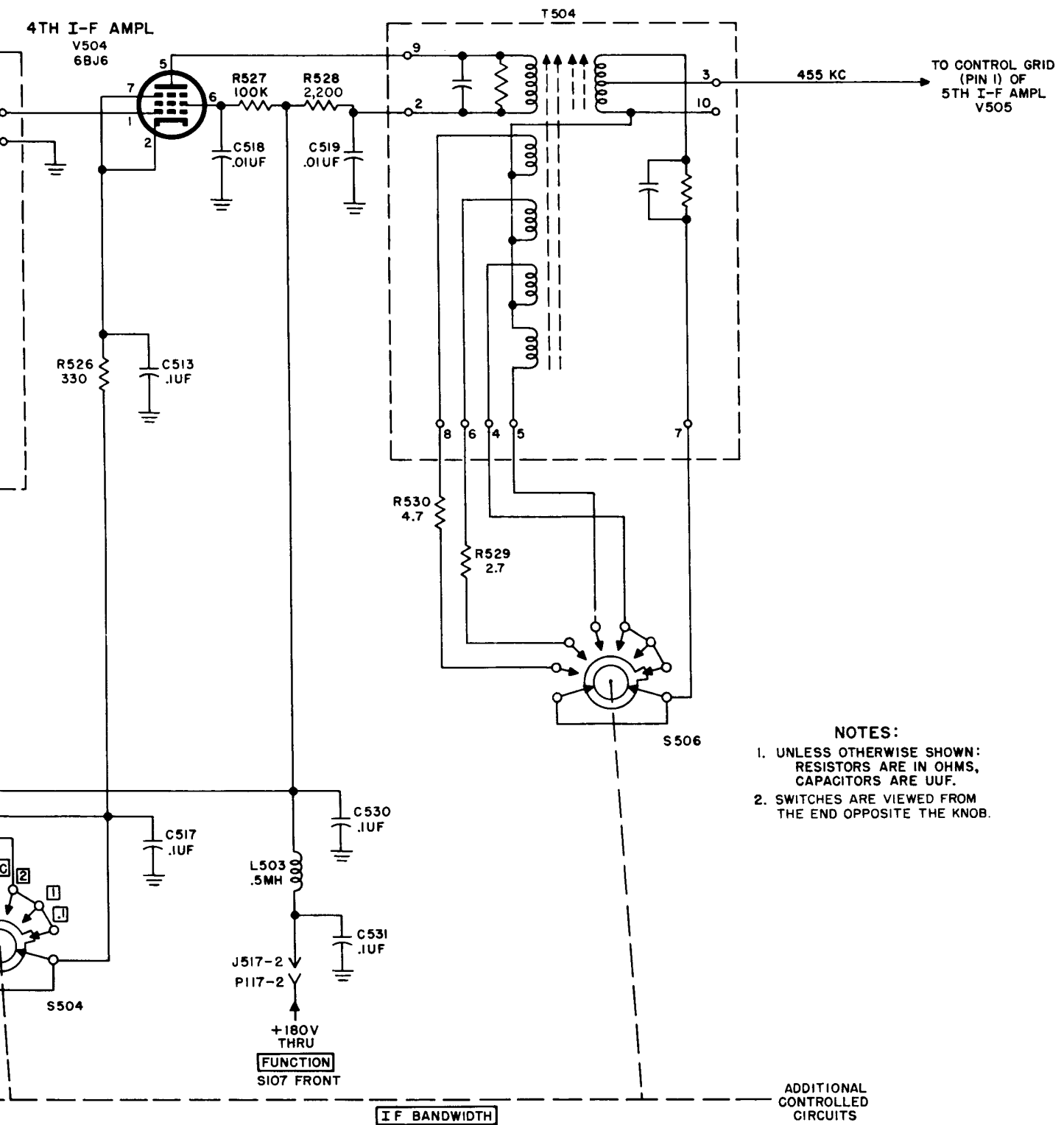

Figure 24. Third and fourth if. ampl



- NOTES:**
1. UNLESS OTHERWISE SHOWN: RESISTORS ARE IN OHMS, CAPACITORS ARE UUF.
 2. SWITCHES ARE VIEWED FROM THE END OPPOSITE THE KNOB.

Third and fourth if. amplifiers, schematic diagram.

tion is the same as that of the second if. amplifier stage, except for certain differences that are described below.

a. Cathode bias for V503 and V504 is decreased as the IF. BANDWIDTH switch is turned from the .1 KC position to the 8 KC position, to prevent the gain of the if. amplifier stages from decreasing. (In the ordinary if. amplifier stage, as bandwidth is increased, the overall stage gain is decreased.) Resistors R518 through R521 are connected, by means of IF. BANDWIDTH switch S504, to bias resistors R517 and R526 of the cathodes (pins 2) of V503 and V504, respectively. The resistors are placed in series with the fixed bias resistors to decrease the control-grid bias and thereby increase the gain proportionately as the band pass is increased. The cathodes are bypassed to ground by capacitors C514 and C513.

b. The signal from the second if. amplifier is fed through coupling capacitor C512 to the control grid (pin 1) of V503 which is returned to ground by R516. A sudden strong signal or a noise impulse at the control grid of V503 causes it to draw grid current momentarily, before the agc circuit can take control and reduce the signal strength. This grid current, flowing through the common cathode circuit of V503 and V504, produces an additional bias voltage which would block V504. Thus, no signal would reach the agc circuit, and the receiver would remain blocked until the input signal to V503 was reduced. Resistor R516 limits the flow of grid current to a very small amount that has negligible effect on the cathode bias and prevents blocking. R522 and R527 are voltage-dropping resistors for the screen grids of V503 and V504, respectively. The screen grids are bypassed to ground by capacitors C515 and C518. The plates are connected to B+ through the primary windings of T503 and T504. Resistor R523 with capacitor C516, and R528 with C519, decouple the plate circuits from the common B+ circuits.

c. The amplified signal at the plate is coupled by T503 to the control grid (pin 1) of V504. The amplified signal at the plate of V504 is fed in a similar manner through T504 to the control grid of V505.

d. Four degrees of selectivity can be chosen by connecting one of four windings in transformers T503 and T504, through IF. BANDWIDTH switches S505 and S506. A small capacitor across each primary and an rc network in series with each secondary provide the required pass band.

Two of the windings in each transformer have a series resistor. Resistors R534 and R525 are used to T503, and resistors R529 and R530 are used to T504. These windings and resistors contribute to the final selectivity of the if. amplifier system.

72. Fifth If. Amplifier V505

(fig. 25)

The fifth if. amplifier stage uses a miniature pentode tube, type 6BJ6. This stage is similar in operation to the previous if. amplifier stages, except for certain differences that are described below.

a. The control grid (pin 1) of V505 is connected to the agc circuit through part of the secondary winding of T504, resistor R509, J517-6 and P117-6, terminals 4 and 3 of TB104, and FUNCTION switch S107. If. signals are isolated from the agc circuits by decoupling resistor R509 which is bypassed by C508. The operation of the FUNCTION switch and agc circuit is the same for this stage as is described for the first if. amplifier stage (par. 69). The cathode is connected to ground through minimum-bias resistor R531, J517-16 and P117-16, RF GAIN control terminals 1 and 2 of TB104, and RF GAIN control R105. Capacitor C520 is the cathode bypass capacitor. The operation of the RF GAIN control is the same as that described for the first if. amplifier stage except that the level of the signals at this stage is much higher; therefore, additional isolation of the cathode circuit from the other controlled stages is provided by L501. The screen grid is bypassed to ground by C521 and is connected to the junction of R511 and R532, which form a voltage divider across the 180-volt supply. The plate circuit is completed to B+ through the primary of T505 and decoupling resistor R533 which is bypassed by C522. Additional filtering of the supply voltage is supplied by L503 and capacitors C530 and C531, a pi-type filter which prevents rf signals from entering the power-supply circuits.

b. The 455-kc signal from the preceding amplifier, V504, is coupled, through T404, to the control grid of V505. The output at the plate circuit of V505 is coupled by T505 to the control grid of V506. The output signal is also coupled to the control grid of agc amplifier V509 through C539, and is coupled directly to the control grid of if. cathode follower V511B.

73. Sixth If. Amplifier V506

(fig. 25)

The sixth if. amplifier uses a miniature pentode tube, type 6AK6. This stage is similar in operation to the previous if. amplifier stages, except for certain differences that are described below.

a. The 455-kc signal from fifth if. amplifier V505 is applied through T505 to the control grid of V506.

b. Cathode bias is provided by resistor R536 and potentiometer R537 in series. In addition to providing a portion of the cathode bias, variable resistor R537, designated CARR-METER ADJ, is used in the CARRIER LEVEL meter (M102) circuit. The cathode is bypassed to ground by capacitor C523. The control grid of this stage is returned to ground through part of the secondary of T505. Voltage to the screen grid and the plate is supplied from the dc source through decoupling resistor R538. The screen and plate return circuits are bypassed to ground by C524.

c. Because the output signal from the bfo, V508, appears in the secondary circuit of T506, it is coupled into the primary winding. To prevent the beat frequency signal from appearing in the grid circuit of V506, neutralizing capacitor C525 is used to overcome the effect of interelectrode capacitance in V506. Together with the lower half of the primary of T506, C525 provides a feed-back voltage of equal amplitude but opposite phase to any signal fed from the plate circuit to the grid circuit through the capacitance between control grid and plate.

74. Control of If. Bandwidth

The pass band of the if. amplifier system can be varied in six steps by the IF. BANDWIDTH switch over a range extending from .1 kc to 16 kc. The 16-kc position is not used in this equipment. This range is obtained by the effects of the crystal filter (Z501) and by controlling the mutual coupling between the windings of the interstage transformers (T501 through T505).

a. Mutual coupling in the transformers is controlled by the use of coils wound on the same form as the primary or secondary winding. Three of these coils are used in T501 (fig. 23), and four are used in the remaining if. transformers. The effect of these coils is to aid or oppose (depending on how they are connected) the mutual coupling that exists between the primary and secondary of the transformer. When the mutual inductance is

increased, the bandwidth is broadened; when the mutual inductance is decreased, the bandwidth is narrowed. The coils shown schematically nearest to the secondary windings provide the widest bandwidth. One coupling coil at a time is connected in each transformer to produce a given degree of inductive coupling.

b. A series coupling circuit that includes contacts of the IF. BANDWIDTH switch, a selected coupling coil, and a capacitor connected in parallel with a resistor, is connected across each secondary winding to obtain a given bandwidth. Resistors of different values in series with the coupling coils also may be included, when needed, to increase the bandwidth. Each of the primary and secondary windings is covered by a magnetic cup, and is alined by a powdered-iron slug.

- (1) When the IF. BANDWIDTH switch is in the position marked .1 KC, 1 KC, or 2 KC, transformer coupling circuits remain unchanged; narrow bandwidths for the .1 KC and 1 KC positions depend on circuit changes in crystal filter Z501. In these three positions of the IF. BANDWIDTH switch, the coupling coil (phase aiding) mounted at the greatest distance from the primary winding of transformer T501 is in the circuit. Transformers T502, T503, T504, and T505 in these positions use coupling coils that are phase-opposing. These provide the sharpest selectivity, because the smallest degree of coupling exists between the primary and secondary windings.
- (2) When the IF. BANDWIDTH switch is the 4 KC position, the coupling circuit of transformer T501 remains the same as for the first three positions. Coupling coils that are at the greatest distance from the primary windings of T502, T503, T504, and T505 are connected phase-aiding to increase the inductive coupling between the respective primary and secondary windings.
- (3) When the IF. BANDWIDTH switch is in the 8 KC position, the middle coupling coil of transformer T501 and series resistor R507 are connected into the coupling circuit. The coupling coils in the second positions from the primary windings of transformers T502 through T505, and series resistors R514, R524, R529, and

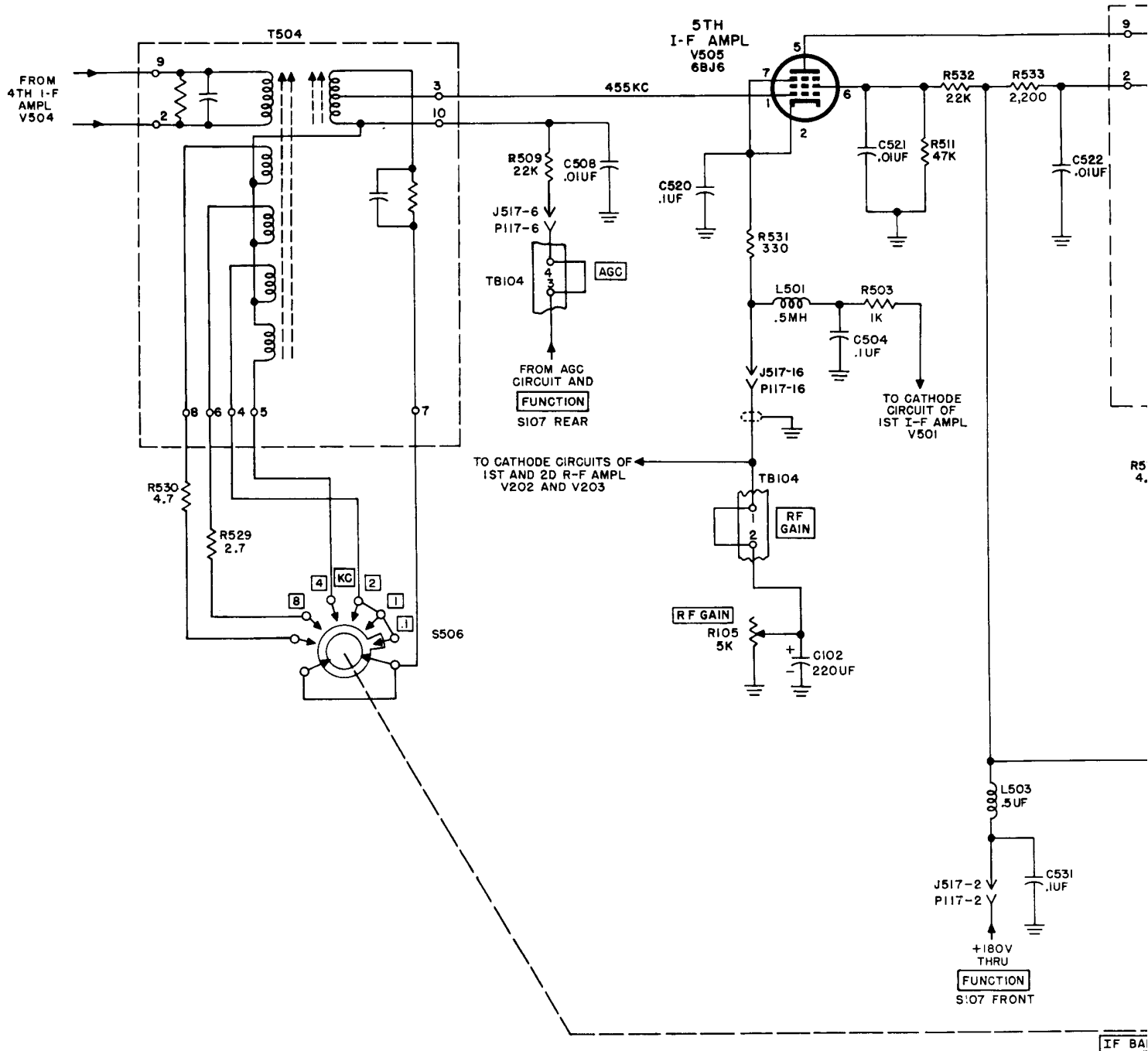
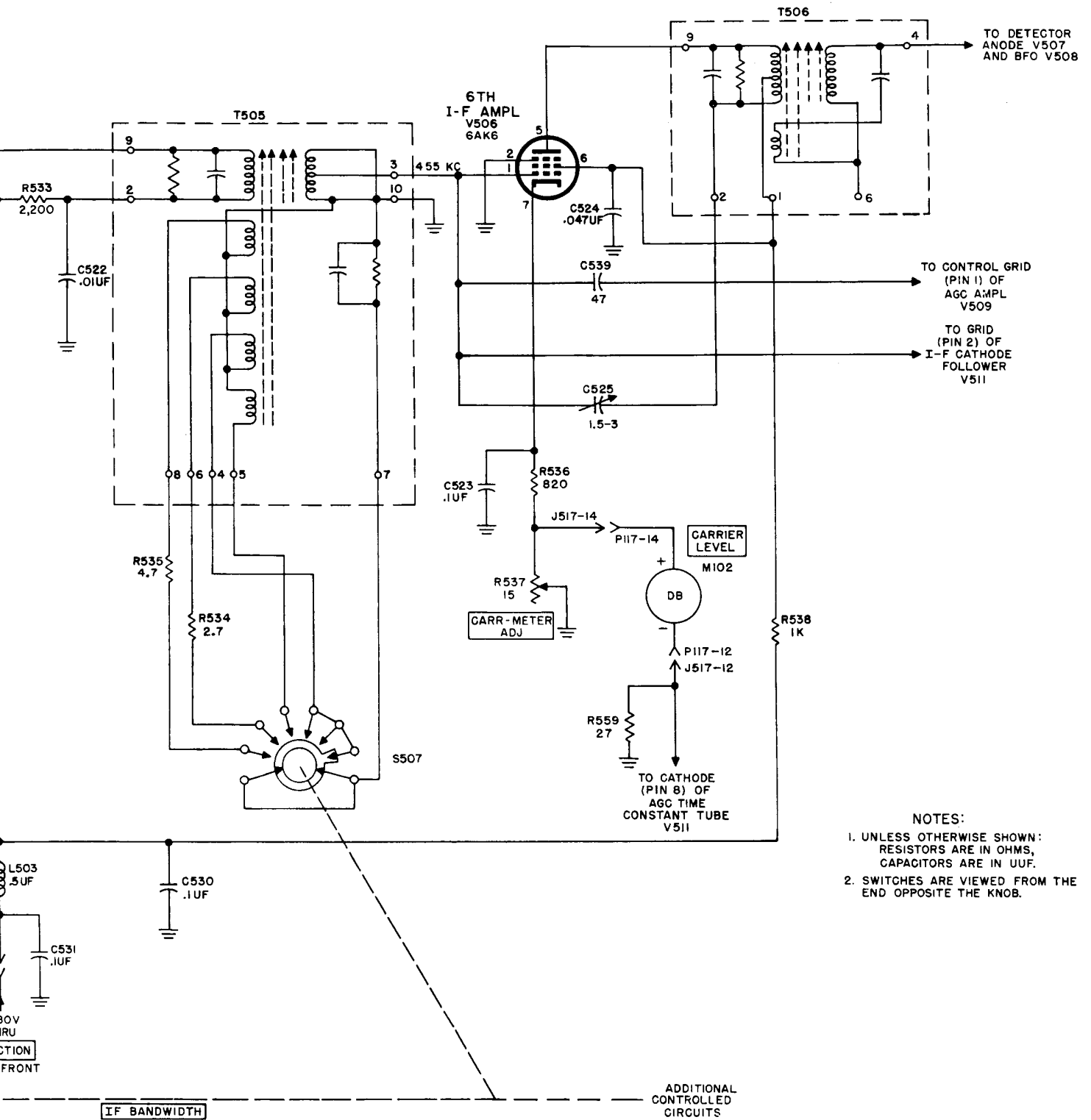

Figure 25. Fifth and sixth if. amplifiers,



NOTES:

1. UNLESS OTHERWISE SHOWN: RESISTORS ARE IN OHMS, CAPACITORS ARE IN UUF.
2. SWITCHES ARE VIEWED FROM THE END OPPOSITE THE KNOB.

and sixth if. amplifiers, schematic diagram.

R534, are included in the remaining coupling circuits. In this switch position, the windings of transformer T501 are not coupled as closely as are the windings of T502, T503, T504, and T505, so that the single-peak frequency response of T501 fills in between the double-peak frequency response of the succeeding circuits, which are overcoupled.

c. Transformer T506 does not have provision for varying selectivity. The 22,000-ohm resistor across the primary winding (terminals 2 and 9), and the capacitor across the secondary winding, permit any bandwidth selected in the previous stages to pass through the transformer to the detector without attenuation.

75. Detector and Limiter Circuits

(fig. 26)

The function of the detector is to demodulate the 455-kc if. signal in order to recover the intelligence from the received signal. The function of the limiter is to minimize interference by removing noise peaks that exceed the amplitude of modulation. The detector and limiter circuits are discussed together because the output of the detector is always applied through the limiter circuit to the af amplifier, section A of V601.

a. *Detector.* The detector supplies an audio signal for application to the limiter and af stages.

- (1) The detector uses one-half of V507, a type 12AU7 miniature dual-triode tube, connected as a half-wave diode rectifier. The plate and control grid (pins 1 and 2) act as an anode, which is connected to the secondary of T506. The ground-return circuit from the secondary includes choke L502 and the diode load, which consists of resistors R539 and R540. The cathode (pin 3) is grounded.
- (2) The if. signal from the sixth if. amplifier is applied through T506 to the detector plate. During each positive half-cycle of the if. signal, the plate is positive and the tube conducts. Choke L502 and capacitor C526 bypass if. signals, but permit the audio variations to pass through the diode load, so that an af voltage appears across the load. The af voltage developed between R540 and ground is applied, through coupling capacitor C527, to the negative-peak

limiter, one-half of V507. The negative side of the dc voltage developed across both R540 and R539 is applied, through a jumper connection on TB103, P119-6 and J619-6, and R610, to the control grid (pin 2) of the squelch tube, one-half of V601. LIMITER control R102, shunted across the load, provides an adjustable voltage for use in setting the operating level (threshold) of the limiters.

- (3) The output of bfo V508 is coupled to the detector plate through capacitor C536. The bfo signal is heterodyned with the if. input signal to produce a beat note.

b. *Limiter.* The limiter couples the audio signals from the detector to the audio stages. When LIMITER switch S103 is set to the *on* position, the peak amplitude of the detector output is limited to eliminate noise peaks above a certain threshold (limit).

- (1) The limiter circuit uses two triode tube sections, connected as diode series limiters, to provide limiting of both positive and negative noise peaks. The negative-peak limiter uses one-half of V507, a type 12AU7 miniature dual-triode tube, and the positive-peak limiter uses one-half of V510, another 12AU7 tube. When LIMITER control R102 is turned counterclockwise to the zero position, switch S103, which is ganged to the limiter control, grounds the parallel-connected cathodes through R544, and removes the ground connection at the junction of resistors R541 and R542; this permits the plates to become positive since +180 volts is now applied through L503 and R543. With the plates of both diodes at a positive potential and both cathodes grounded, a direct current flows through both diodes. The af signal voltage that is applied to the plate of section B of V507 modulates the dc flowing through this diode and, as a result, the af signal appears across cathode resistor R544. Because resistor R544 is common to both diode circuits, the af signal voltage also modulates the dc flowing through section B of V510 and appears across R542 at the plate. From this point, the signal is coupled through C529, and is applied through J517-7 and

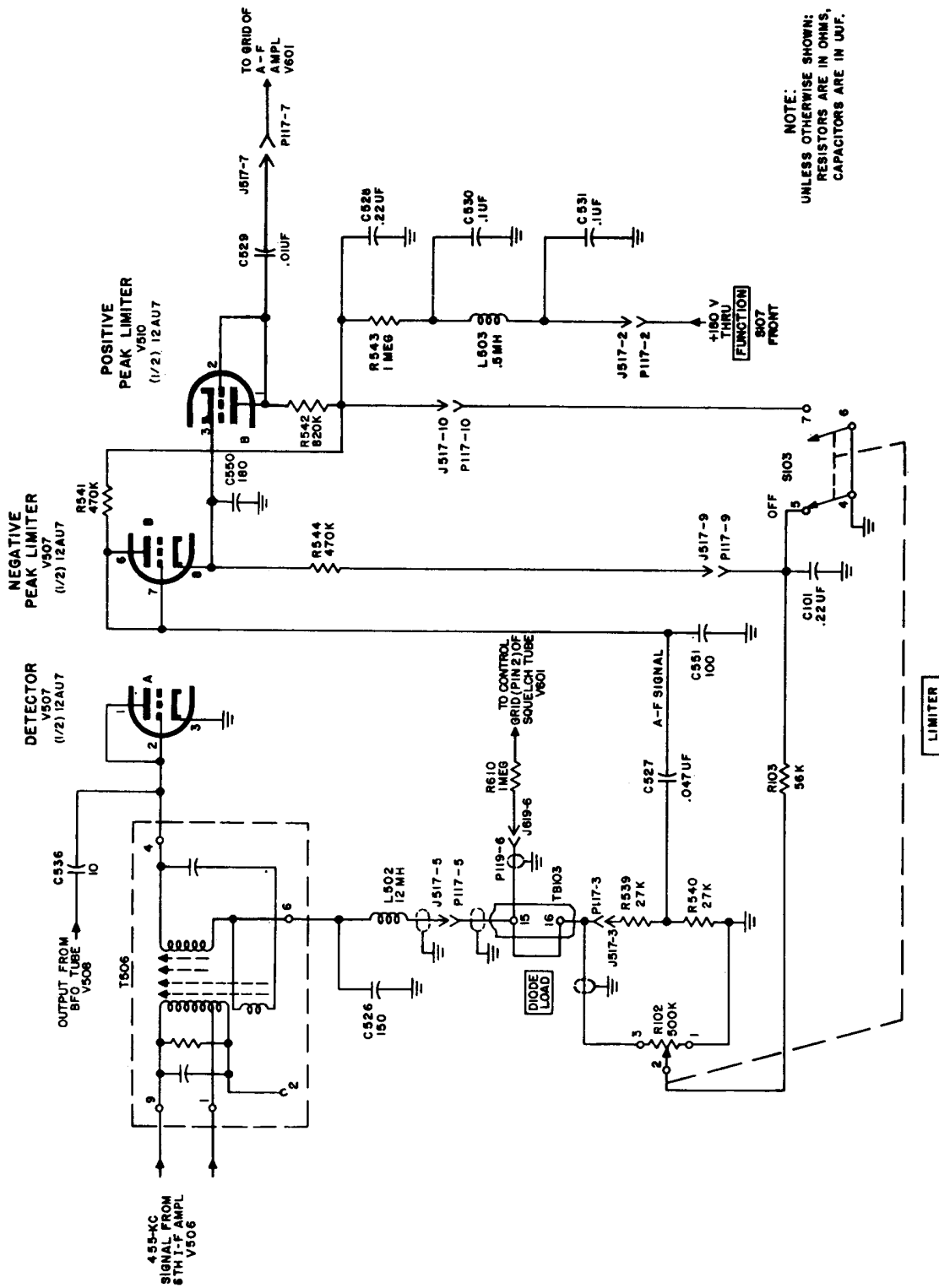

Figure 26. Detector and limiter circuits, schematic diagram.

P117-7 to the control grid (pin 7) of the first af amplifier, section A of V601. The decoupling network consists of L503, C530, and C531. In the off position of S103, R543 and C528 perform the same function. The purpose of C551 is to bypass any if. components that might be present in the output of the detector stage. Resistor R103 prevents excessive loading of the detector output as a result of the grounding of cathode resistor R544.

- (2) When the **LIMITER** control is turned in a clockwise direction, switch S103 grounds the junction of plate-load resistors R541 and R542 and removes the ground on the cathodes of the diodes. As a result, the cathodes assume a negative threshold potential which is adjustable by means of **LIMITER** control R102. The diodes are thus converted into negative (one-half of V507) and positive (one-half of V510) peak limiters. Again, direct current flows through the diodes and as long as it flows, the af signal is transferred through the diodes as before. However, any negative-going impulse that drives the plate of V507 more negative than the cathode will cut off the diode, and that impulse will be limited to an amplitude equal to the threshold voltage. Similarly, any positive impulse that overcomes the threshold potential on the cathode of V510 will cut off that diode, and the positive impulse will be limited. As the **LIMITER** control is turned toward position 10, a less negative threshold voltage is applied to the diodes, and more severe limiting results. Since the threshold voltage at any given setting of the **LIMITER** control varies with the average amplitude of the diode load signal, the limiting action automatically adjusts itself—at low modulation levels greater limiting takes place, and at high modulation levels less limiting takes place. Capacitor C101 and resistor R103 decouple the limiter circuit from the detector circuit, while C550 stabilizes the threshold voltage at the cathodes.

76. Bfo V508

(fig. 27)

The bfo employs a miniature pentode tube, type 5749, connected as a Hartley oscillator, and its operation is similar to that of the vfo. The bfo is used to aid in accurate tuning of signals and to permit the reception of radiotelegraph signals. When BFO switch S104 is set to ON, the bfo generates a signal which is mixed with the 455-kc if. signal at the input to the detector. The signals heterodyne to produce an audible beat note in the output of the receiver.

a. Bias for the control grid (pin 1) is developed by R545 and C532. A positive potential is applied to the screen grid (pin 6) through voltage-dropping resistor R546 and decoupling resistor R548, and contacts 1 and 3 of BFO switch S104. Capacitor C534 provides a low-impedance signal path from the screen grid to the ground side of Z502. The bfo output signal is developed (by electron coupling to the plate) across resistor R547. The decoupling network formed by R548 and C535 isolates the oscillator from the power supply. When the BFO switch is turned to OFF, B+ is removed from the plate and screen circuits of the oscillator.

b. The oscillator section is a triode in which the screen grid (pin 6) acts as the anode. The control grid is connected, by capacitor C532, to tuned circuit Z502, which consists of a tank coil (two inductors connected in series) and a tank capacitor (three capacitors connected in parallel). The cathode (pin 7) of V508 is connected to a tap near the ground end of the tank coil. The feed-back voltage required to produce and sustain oscillations is induced in the coil by the flow of cathode current through the portion of the coil that is connected between the tap and ground. Because the oscillator output is coupled into the plate circuit by the electron flow within the tube, variations in plate load have little effect on oscillator stability. The amplified signal from the plate is coupled through capacitor C536 to the plate of the detector.

c. Capacitors C532 and C533 form a network which improves frequency stability by placing the grid-input capacitance of V508 across only part of the tank coil. Tube interelectrode capacitance is effectively in parallel with C533; therefore, replacing the tube will not seriously affect the operating frequency. The tuning unit, Z502, is in-

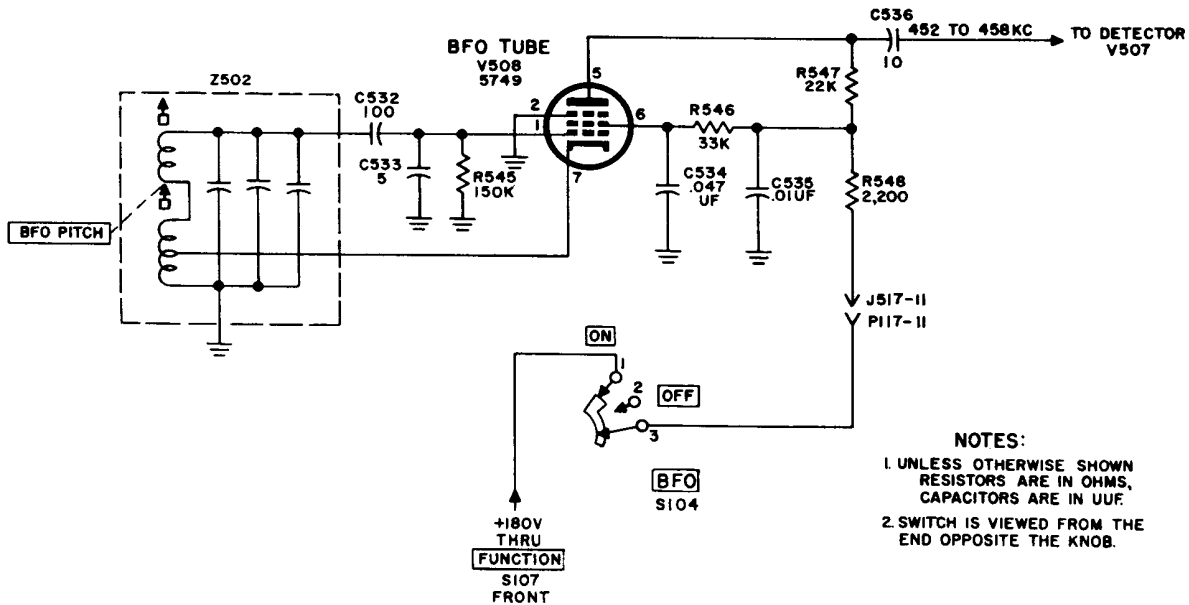

TM 855-39

Figure 27. Bfo, schematic diagram.

closed within a hermetically sealed can. The can should not be opened under any circumstances. Any attempt to perform adjustments will seriously affect the accuracy of the unit.

d. The af produced by the mixing action in the second detector may be varied over an audible range by varying the bfo frequency over a range of 452 to 458 kc. This is done by varying the position of the powdered-iron core within the coil of Z502 (BFO PITCH control). The frequency of the oscillator is caused to vary linearly over its entire range through the action of a special factory-adjusted mechanism. When the control knob on the front panel is set to 0, the output of the bfo is exactly 455 kc; therefore, no audible heterodyne frequency is produced. The zero position of the control knob represents a bfo frequency of 455 kc, and the calibration indicates the number of kc separation (± 3) from the 455-kc if. A screwdriver adjustable slug in the trimmer coil is used to obtain the proper frequency range during alinement and adjustment.

77. Agc Circuit

(figs. 28 and 86)

When FUNCTION switch S107 is turned to AGC or SQUELCH, the agc circuit operates. In the MGC (manual gain control) position, the agc

control line is disabled (grounded). The agc circuit develops a dc potential which is related in amplitude to the strength of the incoming signal. To maintain the receiver output at a constant level, regardless of signal-strength variations, this dc potential is used to bias the grid of the first and second rf amplifiers, V202 and V203, and the first and fifth if. amplifiers, V501 and V505. (In this discussion, these tubes will be designated as the *controlled* tubes.) The delayed-action system prevents the application of agc bias to the controlled tubes during the reception of weak signals, so that maximum receiver gain may be used. The time-constant system permits three degrees of response to be selected by AGC switch S108. Depending on the type of fading experienced and the type of signals being received, the switch is set to FAST, MEDIUM, or SLOW, and thus insures maximum effectiveness of the agc circuit. (A fading signal is an incoming signal that is alternately strong and weak over a given period of time. The circuit uses a miniature pentode tube, type 6BJ6 (V509), and one-half each of two miniature dual-triode tubes (type 12AU7), V510 and V511. Agc if. amplifier V509 is a voltage amplifier operating at 455 kc; one-half of V510, connected as a diode, is used as a rectifier; one-half of V511 is part of the time-constant circuit.

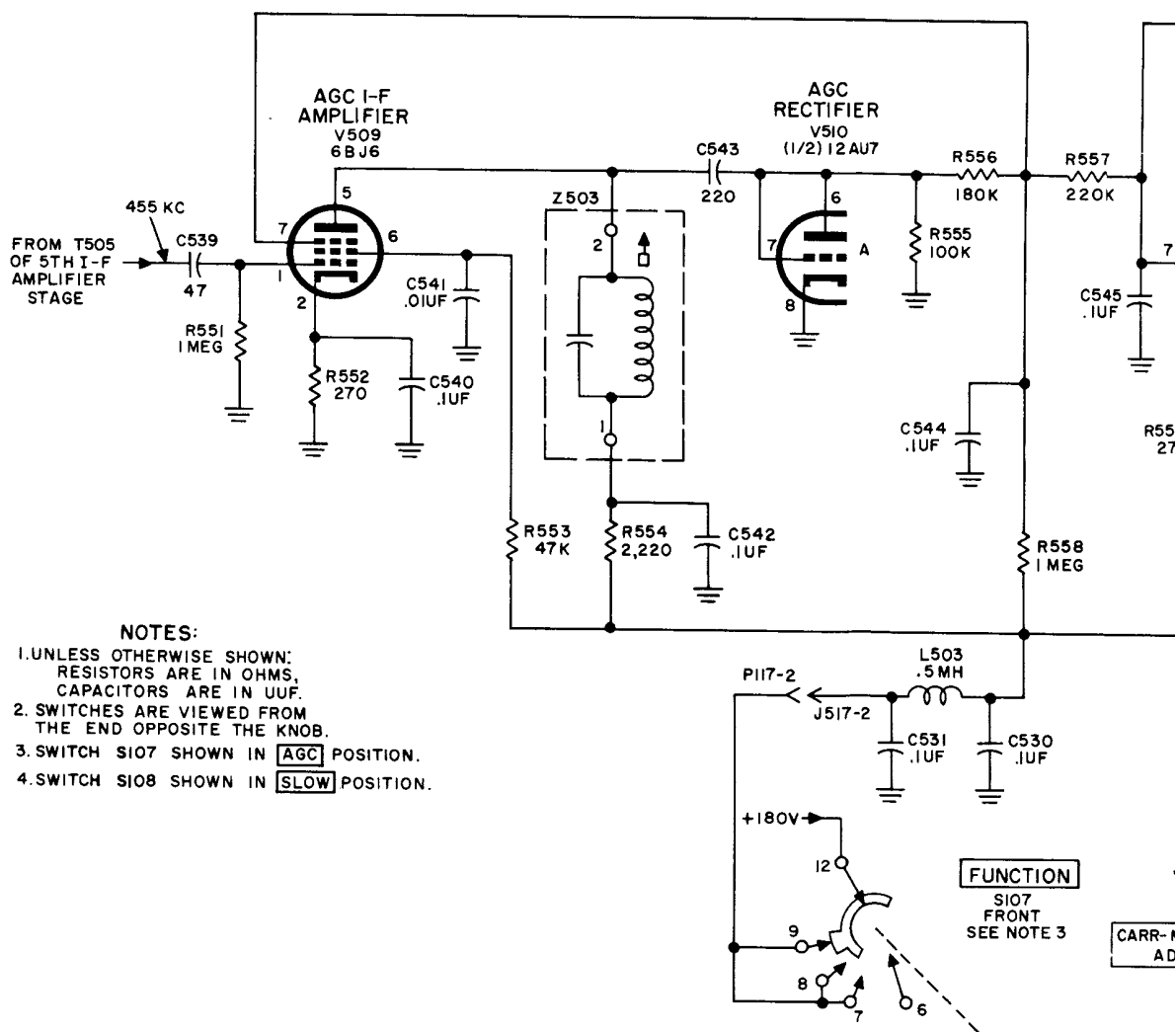

- NOTES:
1. UNLESS OTHERWISE SHOWN: RESISTORS ARE IN OHMS, CAPACITORS ARE IN UUF.
 2. SWITCHES ARE VIEWED FROM THE END OPPOSITE THE KNOB.
 3. SWITCH S107 SHOWN IN **AGC** POSITION.
 4. SWITCH S108 SHOWN IN **SLOW** POSITION.

Figure 28. Agc circuit

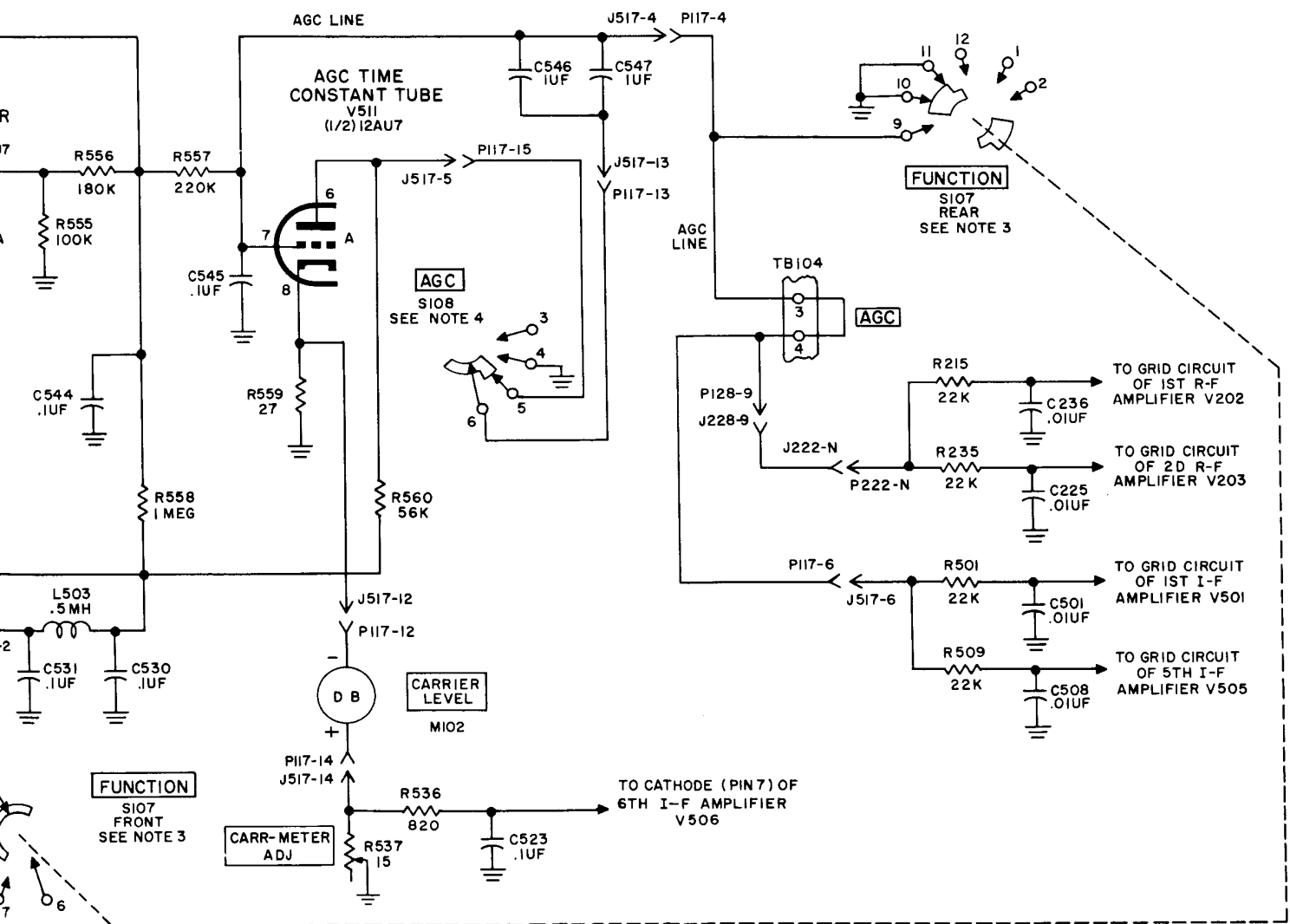

TM 855-40

Figure 28. Agc circuit, schematic diagram.

a. Agc If. Amplifier. This stage (V509) is similar in operation to if. amplifiers V501 through V506.

- (1) The 455-kc signal from the secondary of T505 in the fifth if. amplifier stage is coupled to the control grid (pin 1) of V509; grid leak bias is produced by C539 and R551 at high signal inputs. Cathode bias is developed across R552, which is bypassed by C540. The screen grid is supplied with dc potential through voltage-dropping resistor R553; C541 is the screen-grid bypass capacitor. The suppressor grid (pin 7) is connected as a part of the delayed agc circuit. The plate (pin 5) receives dc potential through the coil of Z503 and decoupling resistor R554. Capacitor C542 and resistor R554 make up the plate decoupling circuit.
- (2) The high impedance of tuned circuit Z503 forms the plate load for the stage. The coil of Z503 has a powdered-iron core that is adjustable for alinement purposes. The amplified signal is coupled through C543 to the plate of the agc rectifier, one-half of V510.

b. Delayed Agc System. The purpose of delaying the agc action is to prevent the application of negative bias to the controlled tubes unless the if. signal has sufficient strength to produce adequate input to detector V507. Maximum gain is therefore provided by the controlled tubes for the reception of weak signals.

- (1) The agc function is made dependent on the strength of the received signal by the action of the circuit consisting of voltage dividers R558, R556, and R555, the suppressor grid of V509, and the agc rectifier. This circuit produces a positive potential on the agc bus which is too small to overcome the negative grid bias produced by the cathode resistors of the controlled tubes.
- (2) During the positive peaks of the if. signal, agc rectifier V510 offers low impedance to ground; therefore, positive peaks do not generate voltage in the diode circuit. During intervals when the applied voltage is negative, the diode is not conducting, and a pulsating negative voltage is developed in the plate circuit across resistor R555. This pulsating

voltage is filtered by resistor R556 and capacitor C544. Capacitor C544 also presents a low-impedance path to ground for the if. signal at the suppressor grid of V509. Under this condition, the voltage at the junction of R556, and R558 is nearly at ground potential because of the high voltage drop across R558 produced by the negative voltage from the agc rectifier and the flow of current into the suppressor grid of V509.

- (3) If a strong signal, however, is applied through C543 to the agc rectifier, a greater negative dc voltage will be developed across R555, in opposition to the positive voltage appearing at the junction of R556 and R557. For input voltages greater than the threshold value, the negative voltage will exceed the positive voltage, and the flow of suppressor-grid current will cease. When this occurs, the negative voltage that is in excess of the positive voltage is applied through R557 and the time-constant circuit to the agc line, and thus the gain of the controlled tubes is decreased.
- (4) The agc voltage is fed, through AGC terminals 3 and 4 of TB104, to the control-grid circuits of the four controlled tubes (fig. 84). Resistors R215, R235, R501, and R509 and capacitors C236, C225, C501, and C508 form decoupling circuits which isolate if. and rf circuits from each other and the agc line. The agc line is grounded when FUNCTION switch S107 is turned to the MGC position. In the MGC position of S107, the gain of the receiver is controlled by RF GAIN control R105. Terminals 3 and 4 on TB104 normally are connected together by a jumper.

c. Time-Constant System. The time constant of the agc line (the time required for the agc voltage to drop to 37 percent of its initial value when the signal is removed) is adjustable in three steps by AGC switch S108. In the FAST position, the time constant is .01 second; in the MEDIUM position, .49 second; and in the SLOW position, 4 seconds.

- (1) *FAST.* In the FAST position, the ability of the agc control voltage to follow fading is maximum; therefore, this

position is excellent for communication work where rapid nonselective fading prevails. The negative agc voltage from the if. signal filter (resistor R556 and capacitor C544) is applied to the second filter (R557 and C545) for af filtering. The time constant is determined solely by the capacitance and resistance connected to the agc line.

- (2) *MEDIUM*. In the *MEDIUM* position, parallel capacitors C546 and C547 are connected across C545 by switch S108, so that the time constant of the agc line is increased.
- (3) *SLOW*. In the *SLOW* position, the ability of the receiver to follow fading is minimum, but this position is very useful for radiotelegraph work because the agc holds receiver gain constant between code groups. When AGC switch S108 is in this position, capacitors C546 and C547 are still used to determine the time constant, but their capacitance appears to be about 10 times as large as in the *MEDIUM* position. This apparent increase in value is achieved by Miller effect in the triode section, one-half of V511. One-half of V511 is a dc amplifier, with the control grid (pin 7) connected to the agc line; the plate (pin 6) is connected through load resistor R560 to B+. The amplified agc voltage across R560 is applied to capacitor C546. The capacitance between the control grid and the plate (in this case, 2 μf) is multiplied by the gain of the tube to give a total apparent input capacitance between the control grid and cathode (pin 8) of 26 μf . This capacitance, together with the remaining capacitance and the resistance of the agc line, further increases the time constant. Cathode resistor R559 serves as part of the bridge circuit for *CARRIER LEVEL* meter M102.

d. CARRIER LEVEL Meter Circuit (fig. 29).

The *CARRIER LEVEL* meter, M102, indicates the relative strength of an incoming carrier signal to assist in tuning, calibration, and alinement. B+ voltage is applied to the plate (pin 5) of V506 and the plate (pin 6) of section A of V511 through L503, which is part of a decoupling and filtering

network consisting of C530, L503, and C531. Resistor R538 provides additional decoupling for sixth if. amplifier V506, and R560 is the plate-load resistor for agc time constant tube V511. The cathode (pin 7) of V506 returns to ground through minimum-bias resistor R536 and *CARR-METER ADJ* resistor R537. The cathode resistor for V511 is R559. The *CARRIER LEVEL* meter, M102, is connected between the cathode (pin 8) of V511 and the junction of R536 and R537. For simplification, the remaining circuit elements of the sixth if. amplifier and those of the time-constant tube are not shown on the simplified schematic diagram (fig. 29). The equivalent tube resistances of V506 and V511 are shown as resistors connected by dashed lines to the cathodes and plates of the tubes. The input to the circuit is the agc voltage from the agc rectifier, one-half of V510, applied to the control grid (pin 7) of agc time-constant tube V511. The circuit arrangement is a bridge with the plate circuits of V506 and V511 as the upper arms and the cathode circuits as the lower arms. Tube V506 is a pentode and has a relatively high value of internal resistance which is constant. The voltage drop across this resistance is constant and, with R536 and R537, provides a steady reference voltage to *CARRIER LEVEL* meter M102. The equivalent resistance of the agc time-constant tube, which is in series with R559, is changed readily. In the absence of agc voltage, as a result of no carrier being received or the carrier level being below the threshold of the agc circuit, no bias is applied to the control grid (pin 7) of V511. Under these conditions, the voltage drops across the triode and the pentode are the same, because they are effectively in parallel across the same power supply. No difference of potential exists across meter M102. When a signal is received, agc voltage is developed. The amplitude of the agc voltage is dependent on the signal level. The higher the level of the signal, the larger the agc voltage developed and applied to the control grid of V511. Under these conditions, the cathode-to-plate current is decreased and the voltage drop across the tube is increased. This results in a change of potential at the cathode (pin 8). No change occurs in the pentode and therefore, a voltage difference is produced across the meter terminals which represents the relative level of the signal being received.

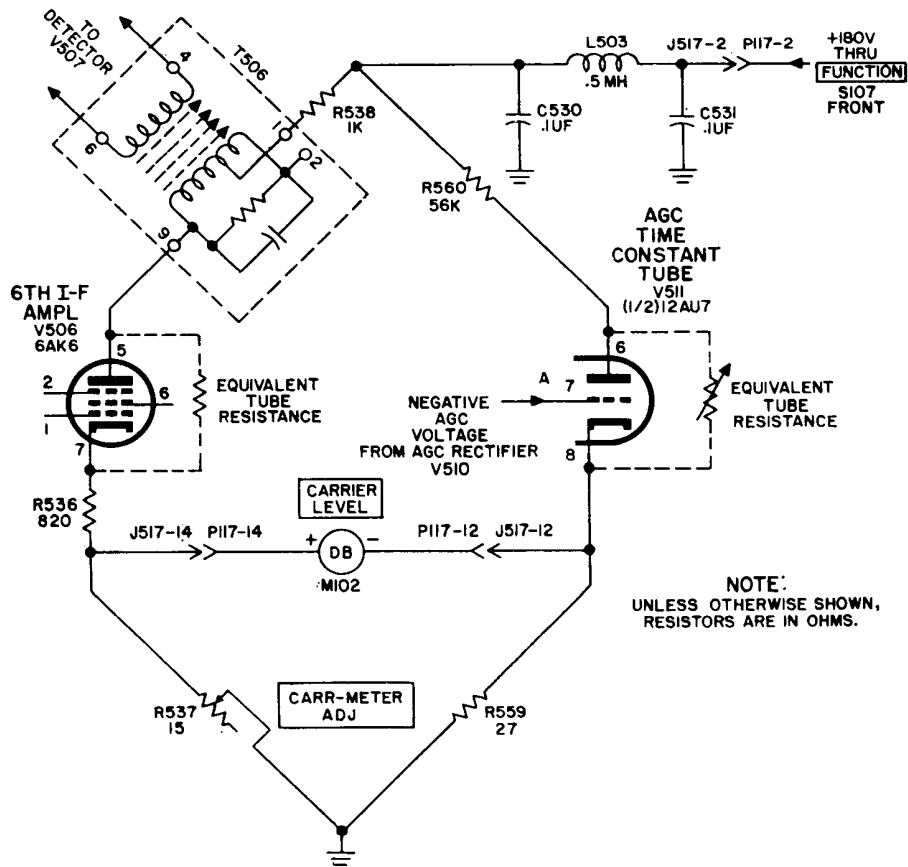

TM 855-41

Figure 29. CARRIER LEVEL meter circuit, simplified schematic diagram.

78. If. Cathode Follower (fig. 30)

The if. cathode follower uses one-half of V511, a miniature dual-triode tube, type 12AU7, to couple the 455-kc signal from the high-impedance secondary winding of T505 to a low-impedance output cable. This matching is necessary when operating Radio Receiver R-389/URR with external equipment such as a frequency-shift teletypewriter.

a. The cathode (pin 3) is connected, through bias resistor R549 and load resistor R550, to ground. Capacitor C537 offers a low-impedance path to the if. signal, and the signal is developed only across R550. The plate (pin 1) is connected directly to +180 volts through L503 which is part of a pi-type filter consisting of C530, L503, and C531.

b. The control grid (pin 2) receives the 455-kc signal from T505 in the output circuit of fifth if. amplifier V505. The plate (pin 1) serves as the ground return for signal current, because all signals at the plate are returned to the cathode by filter L503, C530, and C531. The if. output signal is developed across cathode load resistor R550, and is applied through C538, J512, P112, and the coaxial cable, to IF. OUTPUT 50 OHM J104 receptacle.

c. The cathode follower is well-suited to this application, because external load variations have no effect on the input circuit.

79. Af Amplifier and Filter Circuit (fig. 31)

The af amplifier uses one-half of V601, a miniature dual-triode tube (type 12AU7) to amplify

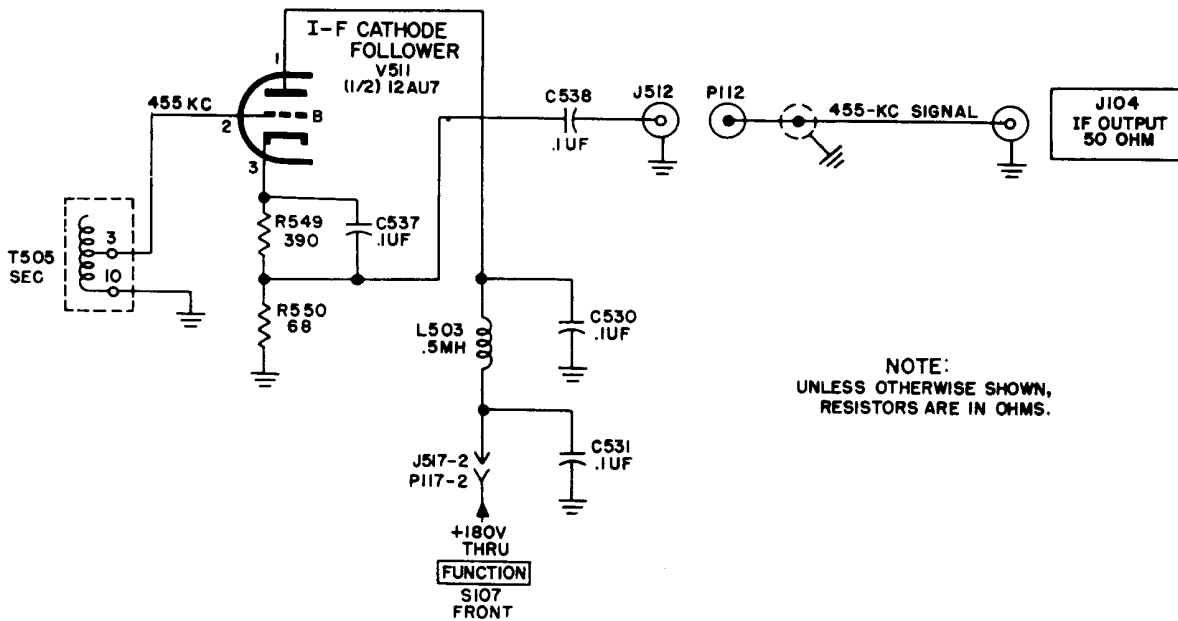

TM 855-42

Figure 30. I-f. cathode follower, schematic diagram.

the audio signal from the positive-peak limiter; the signal is then applied through the filter circuit to the local audio and the line audio channels. The filter circuit selects the range of audio frequencies that are applied to the local and line audio channels. The filter circuits eliminate certain af from the local and line audio channels; thus, noise and interfering signals are reduced appreciably in the output circuits and greater intelligibility of received signals results.

a. Bias voltage for the af amplifier is developed across cathode resistor R602, which is connected between the cathode (pin 8) and ground. The control grid (pin 7) returns to ground through resistor R601. Plate (pin 6) potential is obtained from the 180-volt supply through the primary of T601, decoupling resistor R603 (bypassed by C601), choke L601, J620-6, and P120-6, and FUNCTION switch S107. Additional decoupling and filtering for all the af stages is provided in the B+ line by choke L601 and capacitor C104. By presenting a low-impedance path to ground for the af signal, the decoupling circuits prevent audio modulation of the B+ supply voltage which would cause interference in other circuits.

b. The audio signal output from the limiters is developed across grid resistor R601 and applied to the control grid (pin 7) of section A of V601.

After amplification, the signal appears across the primary of transformer T601. Capacitor C602, which is in parallel with the primary of transformer T601, improves the frequency characteristics of the stage by correcting the transformer impedance in the middle and upper af ranges. From the secondary of transformer T601 (which has an impedance of 600 ohms to match the input of the filter circuits), the signal is applied through the filter to LINE GAIN control R101, LOCAL GAIN control R104, and resistor R119. These components are connected in parallel and have an impedance of 600 ohms to match the output of the filter circuit. The portion of the signal voltage that is applied to the line audio channel depends on the position of the arm of LINE GAIN control R101, and the portion of the signal voltage that is applied to the local audio channel depends on the position of the arm of LOCAL GAIN control R104.

c. Before the signal arrives at the LINE GAIN and LOCAL GAIN controls, it passes through AUDIO RESPONSE switch S106. In the WIDE position of this switch, no frequency-selective circuits are inserted into the signal path; in the MEDIUM position, the low-pass filter is inserted; and in the SHARP position, the band-pass filter is inserted. These filters determine the range of

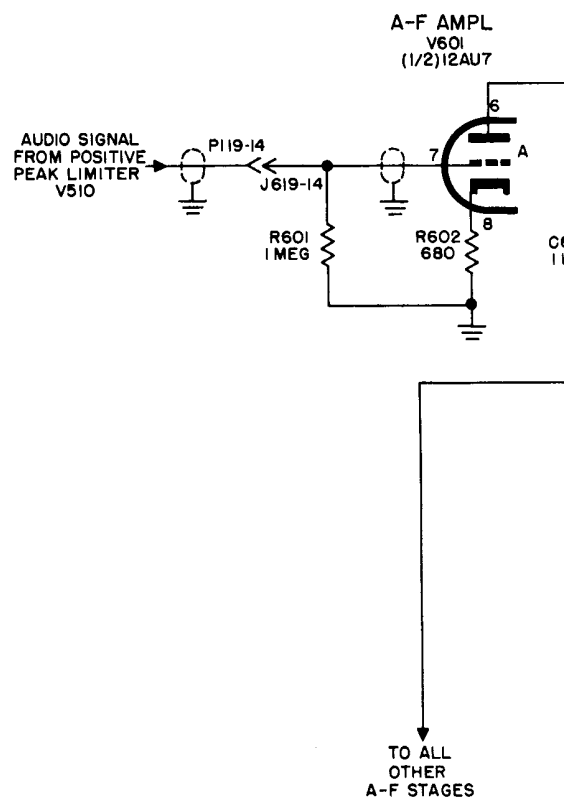

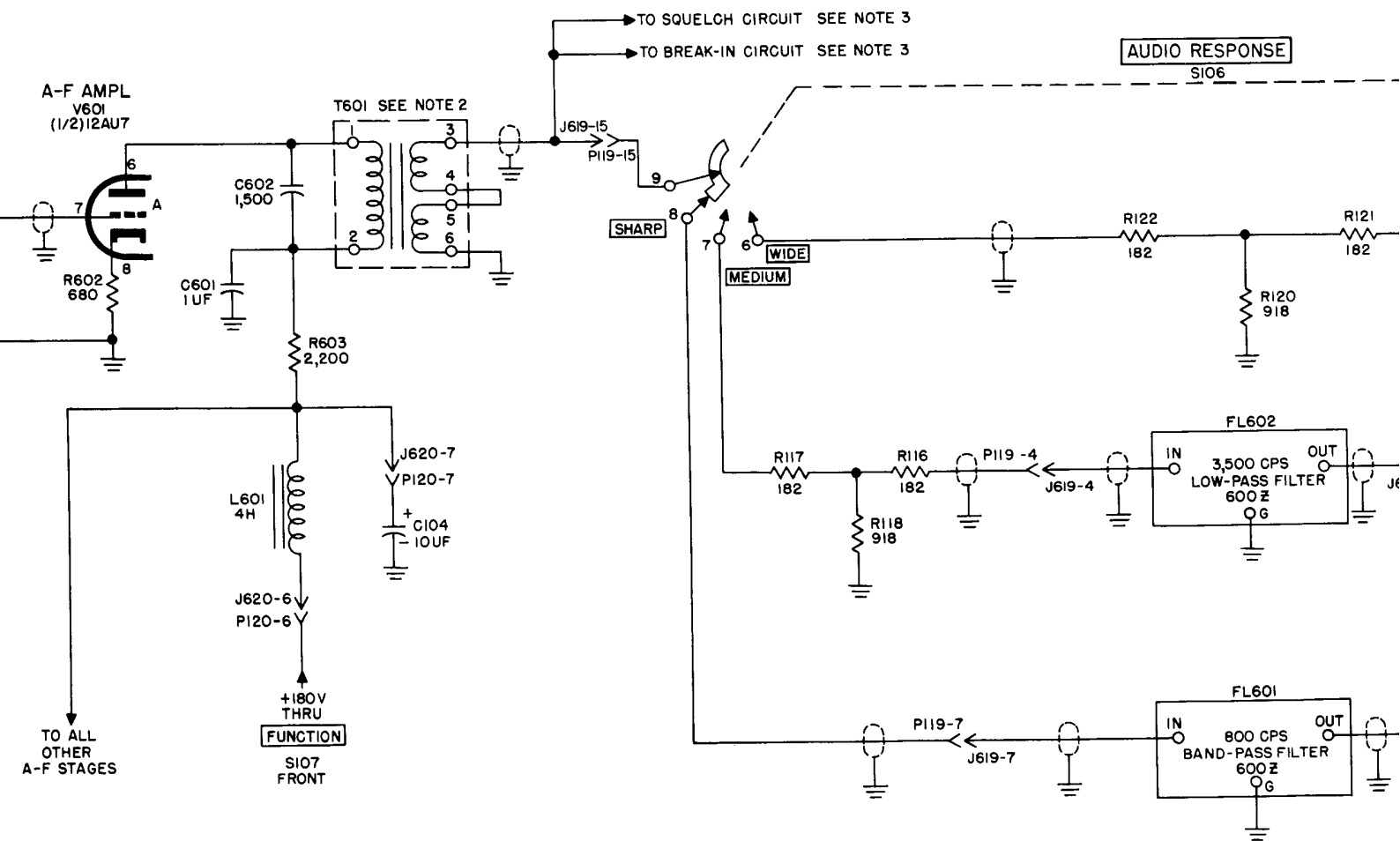
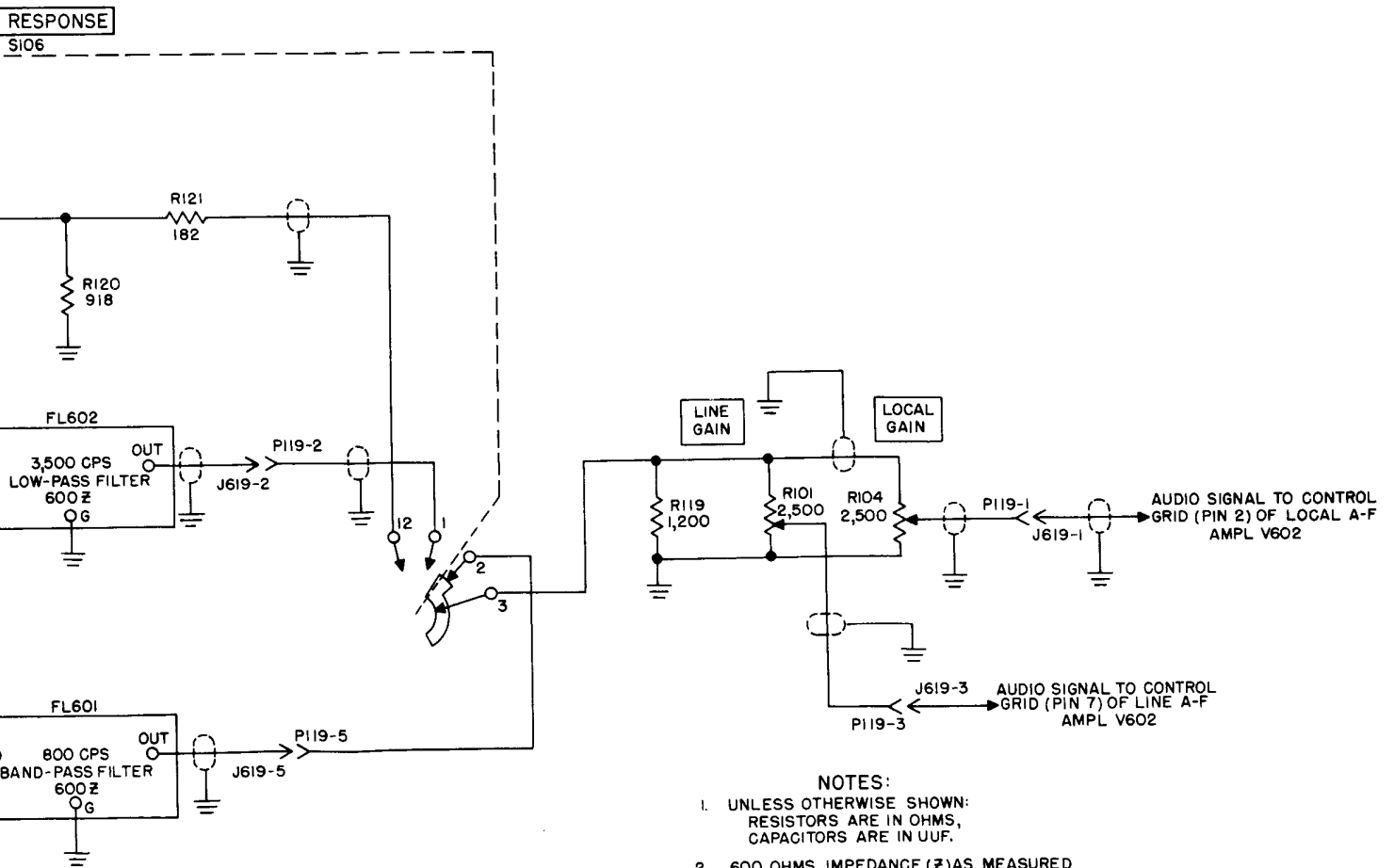

Figure 31. Af amplifier and filter circuit, schematic diagram.



NOTES:

1. UNLESS OTHERWISE SHOWN:
RESISTORS ARE IN OHMS,
CAPACITORS ARE IN UUF.
2. 600 OHMS IMPEDANCE (Z) AS MEASURED
BETWEEN TERMINALS 3 AND 6. 10,000
OHMS IMPEDANCE (Z) AS MEASURED
BETWEEN TERMINALS 1 AND 2.
3. SQUELCH OR BREAK-IN CIRCUIT WHEN
ENERGIZED GROUNDS OUTPUT TERMINAL
3 OF T601.
4. SWITCH IS VIEWED FROM THE END
OPPOSITE THE KNOB.
5. SWITCH S106 SHOWN IN **SHARP**
POSITION.

TM 855-43

schematic diagram.

frequencies that will be applied to the input of the succeeding stages. To maintain the same signal level, regardless of the setting of switch S106, attenuator *T* pads are connected into the circuit in the WIDE and MEDIUM positions of the switch. These pads, consisting of R116, R117, and R118 in the MEDIUM position, and R120, R121, and R122 in the WIDE position, bring the total insertion loss in these positions up to that in the SHARP position. The MEDIUM position of the switch is for use when the greatest intelligibility of voice reception is desired. Filter FL602 attenuates af above 3,500 cps as well as noise or adjacent-channel interference that might appear when the WIDE position is used. In addition, filter FL602 is used with the line audio channel to prevent cross talk (or splattering) in telephone lines as a result of the presence of high-frequency audio components which tend to couple into adjacent lines, through the capacitance between the lines. In the SHARP position, the input to the local and the line audio channels is fed through an 800-cps band-pass filter (FL601). This filter is designed to attenuate by at least 6 decibels (db) all signals below 600 cps and above 1,000 cps, and by at least 30 db all signals below 400 cps and above 1,200 cps. When used by the operator, this circuit aids in the reception of radiotelegraph signals by excluding noise and adjacent-channel interference.

80. Local Audio Channel

(fig. 32)

The local audio channel consists of two stages of Class A amplification. The local af amplifier, one-half of V602, amplifies the audio signal from af amplifier V601 and applies this signal to local af output tube V603, which amplifies the power of the audio signal to a suitable level for operating a loudspeaker or headset. Three different types of feedback are incorporated in this channel to obtain the required output impedance and frequency response.

a. Bias voltage for local af amplifier V602 is developed across resistors R604 and R609, which are connected in series between the cathode (pin 3) and ground. The control grid (pin 2) returns to ground through LOCAL GAIN control R104. Plate (pin 1) potential is obtained from the 180-volt supply through load resistor R605, choke L601, J620-6, P120-6, and FUNCTION switch S107. Choke L601 and capacitor C104 form a

low-pass filter to prevent audio signals from entering the common power-supply circuits. Bias voltage for local af output tube V603 is developed across resistors R608 and R609, which are connected in series between the cathode (pin 7) and ground. The control grid (pin 1) returns to ground through resistor R607. Plate (pin 5) potential for V603 is obtained from the 180-volt supply through the primary of T602, choke L601, J620-6, P120-6, and FUNCTION switch S107. Screen-grid (pin 6) potential is obtained through choke L601, J620-6 and P120-6, and FUNCTION switch S107.

b. The signal voltage from the local af amplifier is developed across the total resistance of LOCAL GAIN control R104. A portion of this signal voltage, depending on the position of the control arm, is applied to the control grid of V602. The signal is amplified in V602 and appears across plate-load resistor R605. The signal is then applied through coupling capacitor C603 to the control grid of V603, where it is amplified. The output from the stage is impedance-matched to 600 ohms by transformer T602. The primary of transformer T602 is shunted by capacitor C604, which improves the frequency characteristics of the stage by correcting the transformer impedance in the middle and upper af ranges. The secondary winding consists of two single windings connected in series by a jumper between secondary terminals 4 and 5. One end (terminal 6) is connected to ground. The signal across the secondary winding is applied across resistors R127 and R128, which are connected in series between terminal 3 of transformer T602 and ground. The signal across resistors R127 and R128 is applied to pin II on REMOTE CONTROL receptacle J103 and terminal 6 of TB104. Pin II of J103 is for side-tone connection from an associated transmitter. The signal from terminal 6 of TB104 is normally applied to a speaker, and the signal from terminal 8, which is at a lower power level because of the voltage-divider action of resistors R127 and R128, is normally applied to a headset. The signal from terminal 8 of TB104 is also available at PHONES jack J101 on the front panel of the radio receiver.

c. Circuits for negative voltage feedback, negative current feedback, and positive voltage feedback are incorporated in the local audio channel to obtain the required output impedance. The circuit for the negative voltage feedback consists of resistors R606, R604, and R609. This circuit

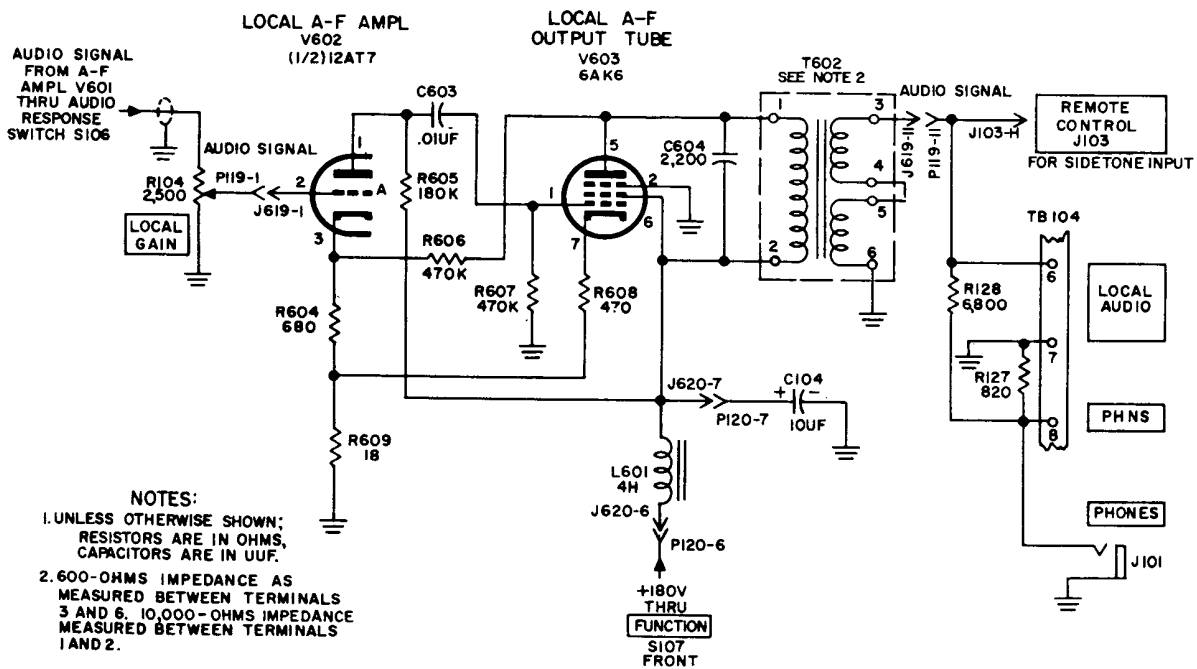

TM 855-44

Figure 32. Local audio channel, schematic diagram.

reduces both the internal impedance of the amplifier and the overall gain, and results in improved stability. Harmonic distortion, noise, and hum are also reduced, because they are fed back with the original signal and reduced in amplitude in proportion to the reduced gain. Negative current feedback is produced by unbypassed resistors R608 and R609 in the cathode circuit of output tube V603, and by R604 in the cathode circuit of local af amplifier V602. This negative current feedback increases the internal impedance of the amplifier. The ratio between the amounts of the two types of feedback is adjusted to set the internal impedance of the amplifier to 600 ohms. A small amount of positive voltage feedback is applied to the cathode of V602 through resistor R606. This eliminates the negative feedback at the cathode that is introduced through resistor R604. The gain of the local af amplifier is therefore equivalent to that produced in a similar amplifier stage employing a cathode bypass capacitor and no negative current feedback.

81. Line Audio Channel (fig. 33)

The line audio channel is similar in operation to the local audio channel (par. 80); however, it

is designed to feed a balanced line that has an impedance of 600 ohms, and it has provision for monitoring the output level of the channel with LINE LEVEL meter M101.

a. Bias voltage for the line af amplifier is developed across resistors R628 and R633, which are connected in series between the cathode (pin 8) and ground. The control grid (pin 7) is connected to ground through LINE GAIN control R101. Plate (pin 6) potential for V602 is obtained from the 180-volt supply through load resistor R629, decoupling resistor R634 (bypassed by C609), choke L601, J620-6 and P120-6, and FUNCTION switch S107. Choke L601 and capacitor C104 form a low-pass filter to prevent audio signals from entering the common power-supply circuits. Bias voltage for V604 is developed across resistors R632 and R633, which are connected in series between the cathode (pin 7) and ground. The control grid (pin 1) is connected to ground through resistor R631. Plate (pin 5) potential for V604 is obtained from the 180-volt supply through the primary of T603, choke L601, J620-6, P120-6, and FUNCTION switch S107.

b. The signal path through the line af amplifier and the line af output tube is identical with the

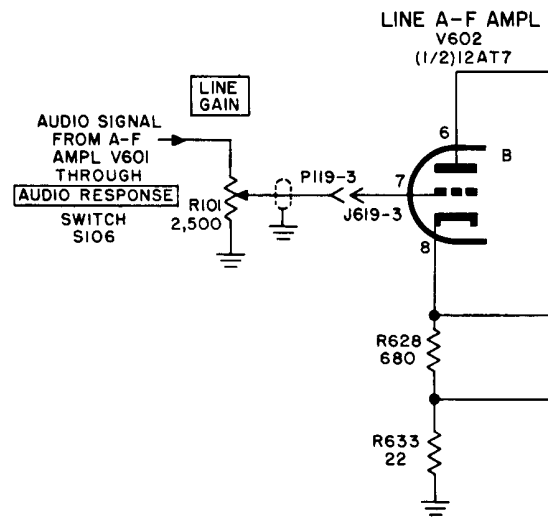

NOTES:

1. UNLESS OTHERWISE SHOWN:
RESISTORS ARE IN OHMS,
CAPACITORS ARE IN UUF.
2. IMPEDANCE (Z) BETWEEN TERMINALS 1 AND 2 IS 600 OHMS. IMPEDANCE (Z) BETWEEN TERMINALS 1 AND 2 IS 10,000 OHMS.
3. S105 SHOWN IN **OFF** POSITION.
4. SWITCHES ARE VIEWED FROM THE OPPOSITE THE KNOB.

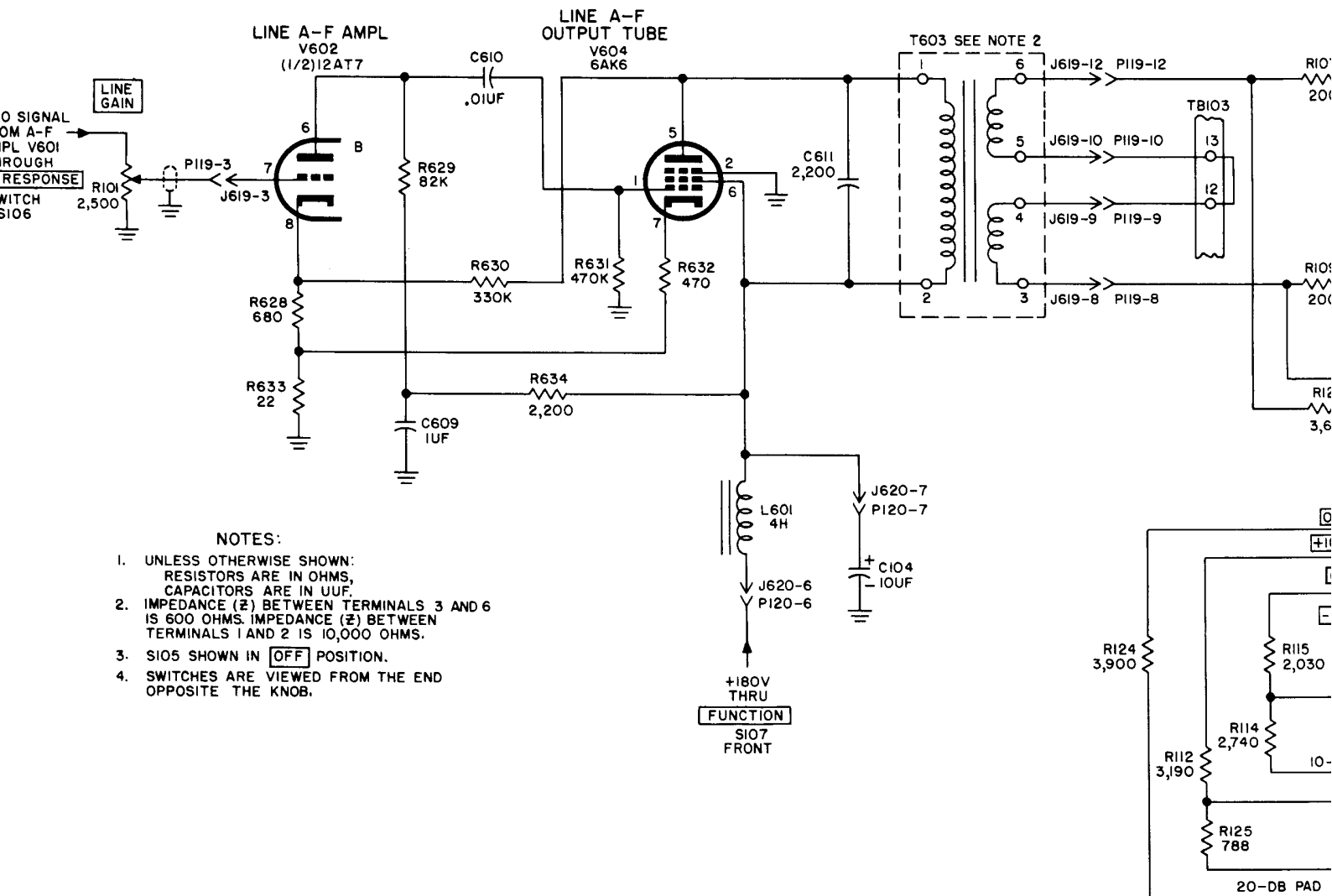
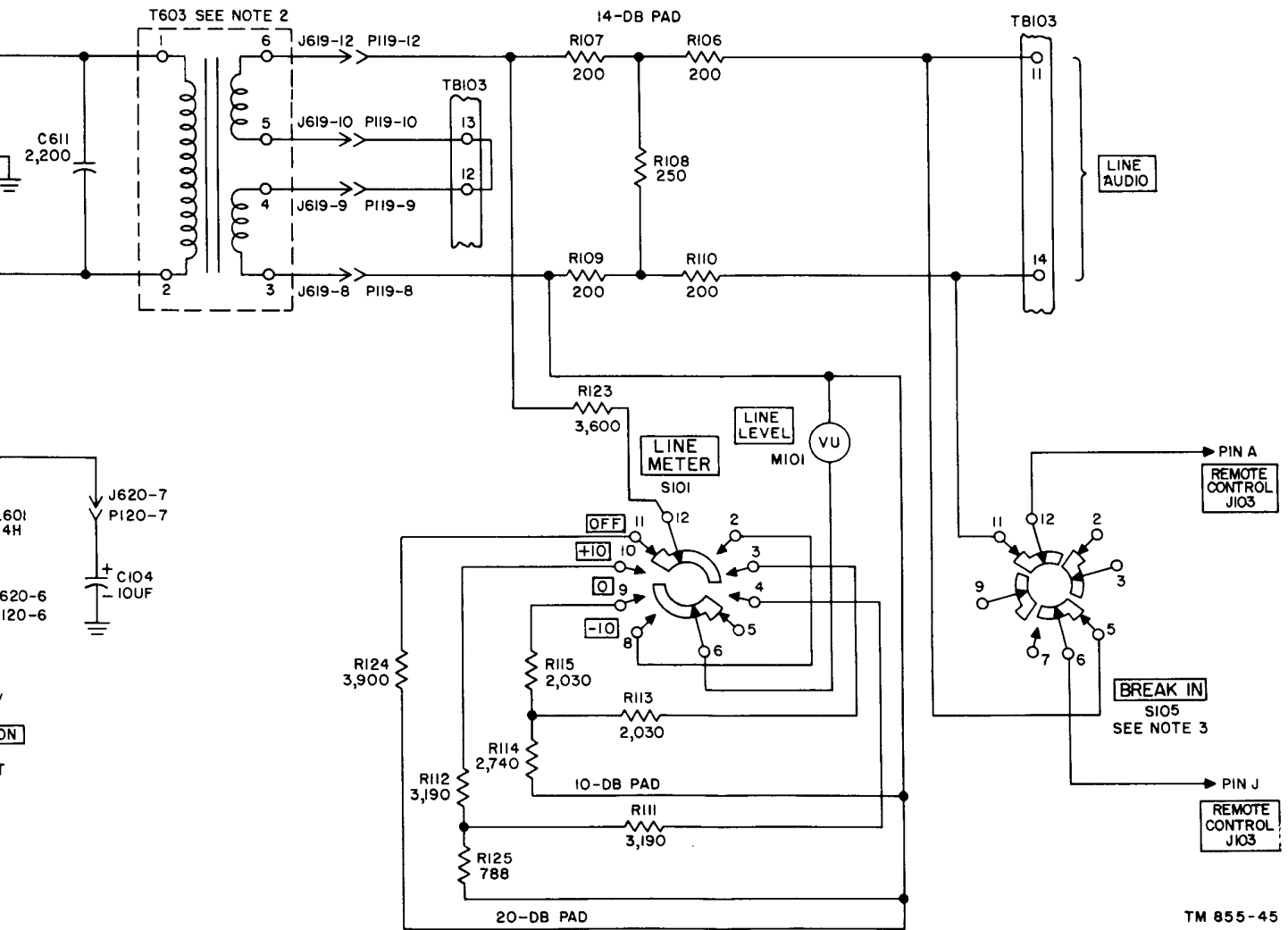

Figure 33. Line audio channel, schematic diagram.



TM 855-45

Figure 33. Line audio channel, schematic diagram.

signal path through the local af amplifiers. The three types of feedback circuits explained in paragraph 80 are also applicable to V602 (section B) and V604. The output circuit of the line audio channel differs from that of the local audio channel in that terminals 4 and 5 of transformer T603 are connected directly to terminals 12 and 13 of TB103. A jumper is normally connected between these terminals of TB103 except under conditions where a balancing network is required to correct the terminal impedance of a line connected to terminals 11 and 14 to 600 ohms. The end terminals (3 and 6) of transformer T603 are connected to an H-type attenuator, consisting of resistors R106 through R110, which reduces the output from approximately 250 milliwatts (mw), so that a maximum of 10 mw of af power is supplied to a 600-ohm balanced line connected to terminals 11 and 14 of TB103, as well as to pins A and J of REMOTE CONTROL receptacle J103. (The H-type attenuator is used to reduce the power level by 14 db to permit the use of a meter having a 4-db sensitivity and still achieve a -10 -dbm output level.) The output is applied to the REMOTE CONTROL receptacle only when BREAK IN relay switch S105 is in the OFF position. LINE LEVEL meter M101 is connected across the output-transformer secondary to indicate the level of the signal being applied to the balanced line. This meter is calibrated in vu, which is based on a zero reference level of 1 mw into 600 ohms, or 0 dbm. For example, an indication of -20 vu or $+3$ vu would be equivalent to -20 dbm or $+3$ dbm. The face of the meter has two scales: the upper scale is calibrated to read directly in vu when LINE METER switch S101 is set to 0 vu; the lower scale is calibrated from 0 to 100, and ends at a point opposite 0 vu on the upper scale. When the output of the receiver is fed into a telephone line, the meter circuit is used to show the line input level. Meter M101 has an impedance of 3,900 ohms. Resistor R123 is connected in series with M101 to match its impedance to the amplifier and to enable the meter to follow closely audio-amplitude changes. To change the range of the meter, switch S101 selects either of two pads or permits direct connection to the meter. For the -10 -vu range, the connection is direct; for the 0-vu range, a pad consisting of R113, R114, and R115 is used; and for the $+10$ -vu range, a pad consisting of R111, R112, and R125 is used. Pads are used as range multipliers to maintain the impedance match. A

fourth position (OFF) of the switch, disconnects the meter from the circuit and substitutes R124 in its place to maintain the impedance match required across the secondary winding of T603.

82. Squelch Circuit

(fig. 34)

The squelch circuit uses one-half of a 12AU7 dual-triode tube V601 which is connected as a dc amplifier. The squelch circuit eliminates noise signals in the output of the audio amplifier when signals are not being received or when the signal level of the desired carrier is too low for useful reception.

a. Cathode bias is developed across resistor R612, which is also part of a voltage-divider circuit that consists of resistors R612 and R613 connected between B+ and ground. B+ is supplied to the stage only when FUNCTION switch S107 is in the SQUELCH position. Resistor R611 and capacitor C605 provide the proper time constant to prevent operation on sharp noise peaks.

b. In the absence of a carrier-frequency signal, no negative bias is applied to the grid (pin 2) of V601 other than that developed across cathode resistor R612. The tube conducts and plate current flows through the coil of relay K601, energizing the relay and closing contacts 1 and 2. Contact 2 is connected to terminal 3 of T601, and contact 1 is connected to ground; therefore, when these contacts close, the secondary winding of transformer T601 is shorted, and the audio amplifiers are disabled. When a carrier-frequency signal of sufficient level is received, the voltage across the diode load (resistors R539 and R540) becomes more negative. This negative voltage, which is applied to the control grid of V601 through resistor R610, causes the plate current to decrease. When the plate current decreases, relay K601 is de-energized and contacts 1 and 2 open; the ground is thereby removed from terminal 3 of transformer T601 and the received signal appears in the output of the audio amplifiers. Resistor R610 and capacitor C605 in the grid circuit of V601 function as an audio decoupling filter to prevent af signals from being applied to the grid, and thus cause chattering of relay K601 in the plate circuit. The setting of RF GAIN control R105 determines the level to which the incoming signal must rise before it can operate the relay circuit.

c. A carrier-control circuit is also incorporated with relay K601. When an adequate signal is

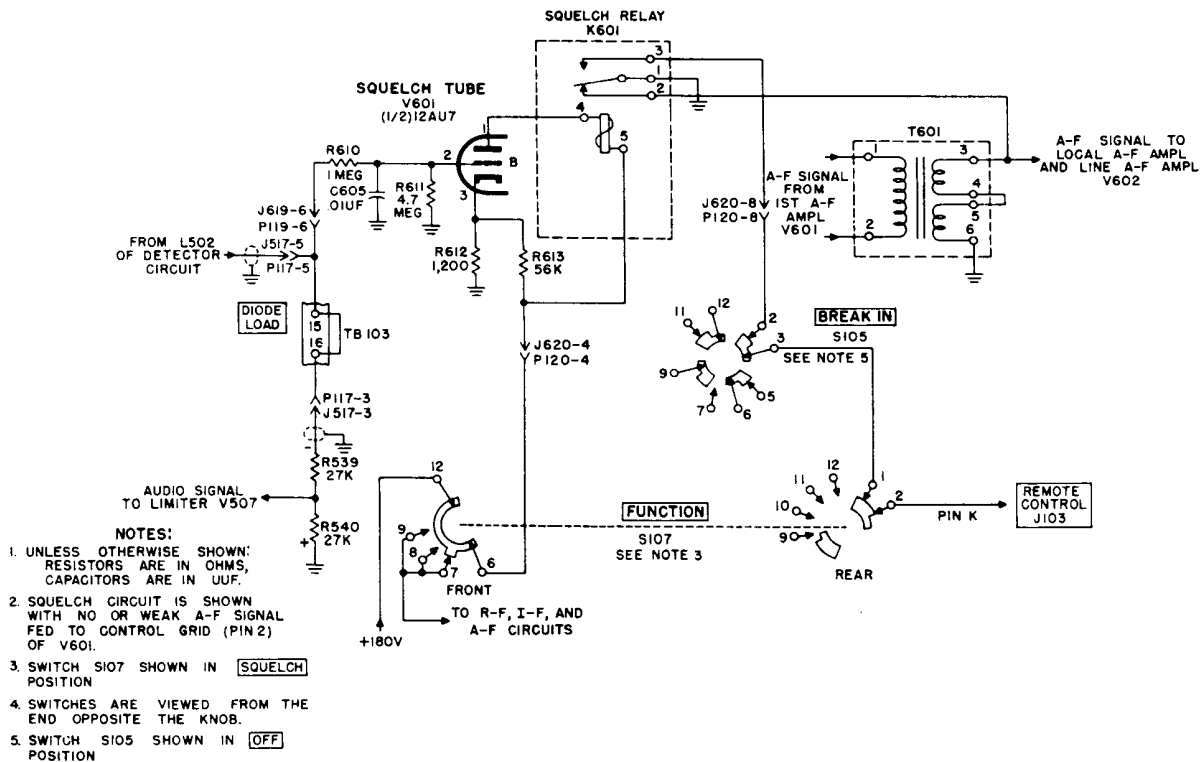

Figure 34. Squelch circuit, schematic diagram.

received, relay K601 is de-energized, and contact 1 makes with contact 3. With **FUNCTION** switch S107 set to **SQUELCH** position and **BREAK IN** switch S105 set to **OFF** position, the closing of these contacts completes the carrier-control circuit of a transmitter through pin K of **REMOTE CONTROL** J103 receptacle.

83. Power Circuits

The power circuits provide regulated B+ voltage to all stages, heater voltage for the filaments of all tubes, ac voltage for the oven heater circuit, ac voltage for tuning motor B202, and dc voltage to operate relay circuits. The power supply consists of two sections or components, Power Supply PP-621/URR and the voltage regulator. A separate dc supply provides voltage for operation of rf band-switching motor B201. Operation of **FUNCTION** switch S107 connects the ac power input to Radio Receiver R-389/URR in all positions except **OFF**.

a. Power Supply PP-621/URR (fig. 35).

- The power supply operates from either 115 or 230 volts, 48 to 62 cycles, and supplies a 300-volt, unregulated, rectified

voltage to the voltage-regulator circuits; 6 volts dc to the relay circuits; and 25.2 volts ac to the filament, oven-heater, and tuning-motor circuits. Primary power is connected to the power supply through **POWER** receptacle J102. The primary of transformer T801 is connected, through switch S801, 3-ampere ac fuse F101, and **FUNCTION** switch S107 to terminals A and D of **POWER** receptacle J102. Transformer T801 contains two separate primary windings to permit selection, by use of switch S801, of either 115-volt or 230-volt operation. For 115-volt operation, S801 connects the two primary windings in parallel and for 230-volt operation, S801 connects the windings in series.

- The ends of the high-voltage secondary (terminals 5 and 7) of transformer T801 are connected to the plates (pins 1 and 6) of rectifiers V801 and V802 (type 26Z5W), respectively. The center tap of the secondary (terminal 6) is grounded. Tubes V801 and V802 are connected as

diodes in a full-wave rectifier circuit. The cathode of each tube (pins 3 and 8) has a protective equalizing resistor between it and the common connection at J818-5. These resistors (R801, R802, R803, and R804) limit the maximum current of each diode section. The low-voltage secondary (terminals 8 and 10) of T401 supplies 25.2 volts ac to the rectifier tube heaters, all remaining heaters, dial lamps, oven heater, and tuning-motor (B202) circuits. A tap (terminal 9) on this secondary winding provides 12 volts ac to terminal 4 of full-wave dry-disk rectifier CR801. The dc output of this rectifier supplies 6 volts for operation of antenna relay K101 and break-in relay K602 through the FUNCTION and BREAK IN switches. The high voltage output from the power supply is fed to the voltage regulator through $\frac{3}{8}$ -ampere fuse F102, and is filtered by input capacitor C103.

- (3) The primary windings of transformer T401 (part of the band-switching motor power supply) are connected in parallel with the primary windings of T801 in such a manner that the operation of switch S801 also connects the primary windings of T401 in parallel for 115-volt operation or in series for 230-volt operation.

b. Voltage Regulator (fig. 36). The function of the voltage regulator is to keep the output voltage of Power Supply PP-621/URR constant, regardless of changes of load current drawn by the receiver or changes in the input supply voltage. The voltage-regulator circuit includes the following: two dual-triode tubes, type 6082 (V605 and V606), which function as a variable series resistance to regulate the dc output voltage; a miniature pentode tube, type 6BH6 (V607), which is a dc amplifier to control the series resistance of V605 and V606 in accordance with voltage variations originating either in the power supply or in the receiver B+ load; and two cold-cathode tubes, type 5651 (V608 and V609), which provide a constant reference voltage for V607. The voltage regulator supplies regulated 180 volts dc to the vfo at all times and, through FUNCTION switch S107 (front), to the if., af, and rf circuits, and to the squeleh circuit. When BFO switch S104

is set to ON, the 180 volts dc is also applied to bfo tube V508. The regulated 180-volt distribution to all circuits in Radio Receiver R-389/URR is shown in figure 87.

- (1) The four plates of V605 and V606 (pins 2 and 5) are connected together in parallel and are supplied unregulated dc voltage from the output of Power Supply PP-621/URR. The four cathodes (pins 3 and 6) are connected in parallel through four resistors (R619, R620, R621, and R622) to a common connection at J601. These resistors equalize the load current of each triode section. The regulated dc output voltage at test point J601 is determined by the voltage drop across the tube resistance, which is controlled by the bias appearing on the four parallel-connected grids (pins 1 and 4). If either the unregulated voltage or the regulated voltage changes, V607 will convert the change into a comparative bias-voltage change at the grids of V605 and V606, and the effective resistance of the series regulators will change in a direction to correct the initial voltage change. A series voltage-divider circuit consisting of voltage-reference tubes V608 and V609, together with resistors R625 and R626, is connected across the voltage-regulated output circuit. Resistor R627 across V608 insures that proper starting voltage will be supplied to V609. A characteristic of these tubes is that the voltage drop across the tube terminals remains nearly constant and independent of current changes. Therefore, any voltage variation that takes place across the series circuit of V608 and V609 also appears across R625 and R626. The voltage changes across R626 are applied, through resistor R624, to the control grid (pin 1) of V607, and similar out-of-phase voltage changes are produced across plate-load resistors R614 (HUM BAL) and R615. Resistors R623 and R618 across the output of the voltage regulator form a voltage divider, the junction of the two resistors being connected to the cathode (pin 2) of V607. Resistor R618, bypassed by C606, provides the cathode bias for V607. The voltage variations which appear at the

NOTES:

1. UNLESS OTHERWISE SHOWN:
RESISTORS ARE IN OHMS,
CAPACITORS ARE IN UUF.
2. SWITCHES ARE VIEWED FROM
THE END OPPOSITE THE KNOB.
3. SWITCH SI07 IS IN AGC POSITION.

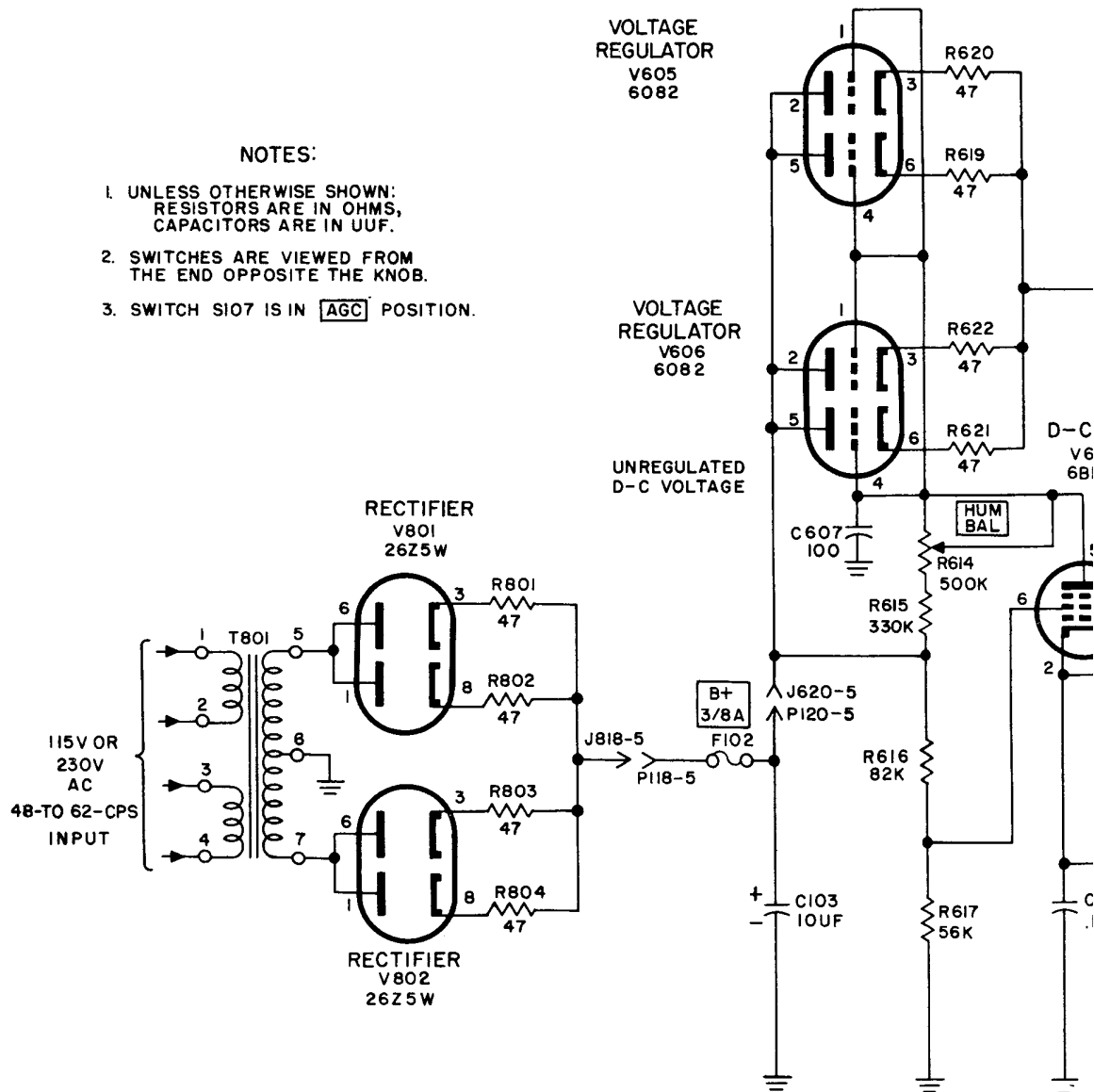

Figure 36. V

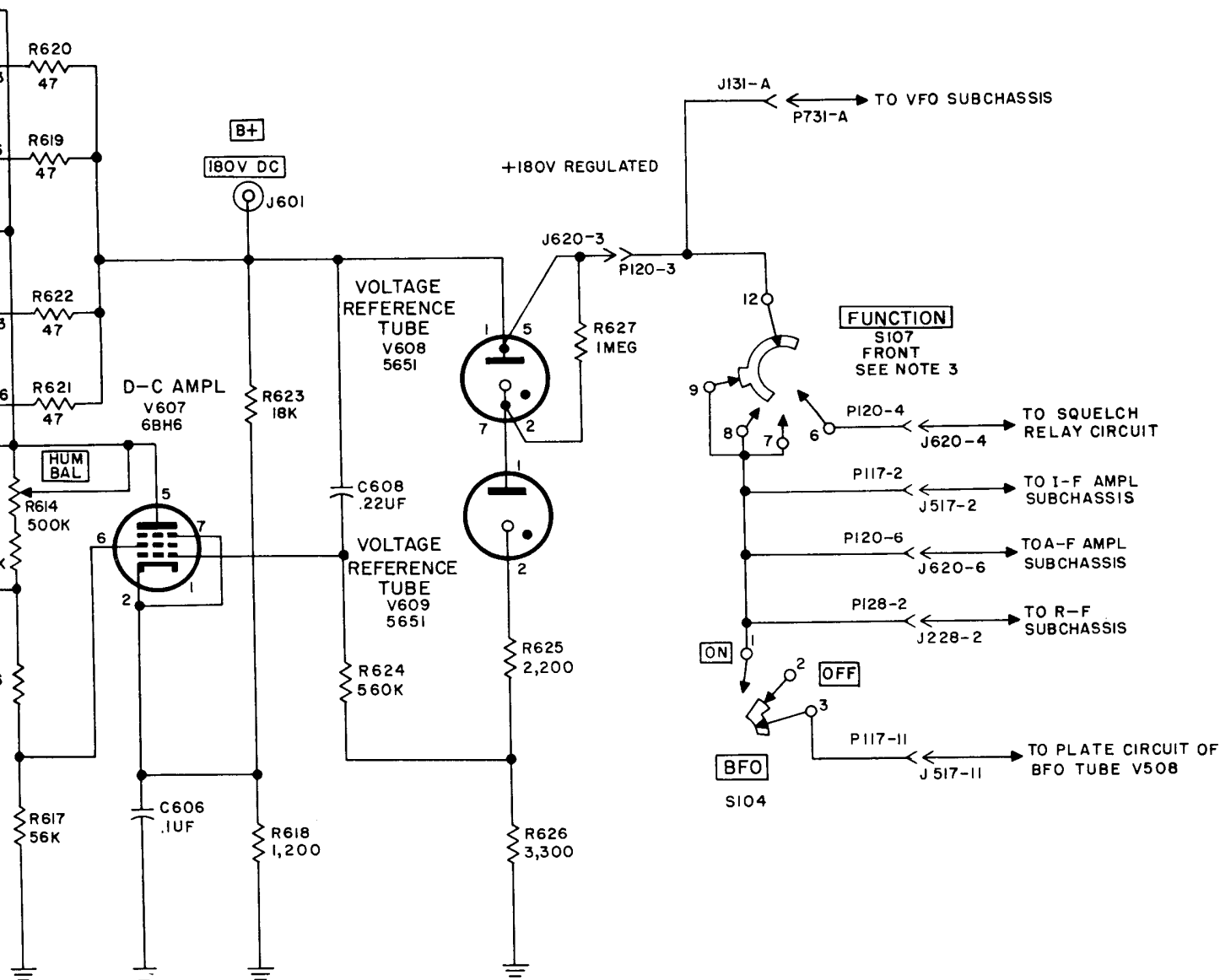

Figure 36. Voltage regulator, schematic diagram.

plate (pin 5) of V607 are applied to the parallel-connected grids of voltage regulators V605 and V606.

- (2) The voltage-regulator circuit operates in the following manner: If the dc voltage at the output of the regulator (J620-3) increases, as a result of a decrease in load current, the increase in voltage will appear across the voltage divider composed of V608, V609, R625, and R626. The increased voltage developed across resistor R626 is applied to the control grid of V607. Although resistors R623 and R618 are also connected across the same output voltage, the change in voltage at the cathode (pin 2) of V607 is relatively small, and is more than offset by the change in voltage produced across R626, which is applied to the control grid through R624. This change in voltage represents a change in bias (less negative) and causes increased current flow through V607 and through plate load resistors R614 and R615. The increased current flow causes an increased voltage drop across the resistors (R614 and R615) and results in a decrease of voltage at the plate of V607. The increased current flow represents a lesser value of positive bias at the grids of V605 and V606. The effective resistance of the regulator tubes is thus increased and causes increased voltage drop across V605 and V606; the voltage at the output of the regulator circuit (J620-3) is decreased to its former value. The action will be reversed when the current in the load increases and, as a result, the output voltage decreases. The action is automatic and produces a nearly constant output voltage. In addition to controlling voltage variations caused by changes in load, the voltage regulator serves to eliminate ripple and hum components that are not removed completely by the rc filter, and variations due to line-voltage changes. Compensation for 120-cps ripple is provided through capacitor C608, which applies the ripple voltage to the control grid of dc amplifier V607. The screen grid (pin 6) is connected, through a voltage divider (R616 and

R617), to the unregulated voltage source at the output of Power Supply PP-621/URR. Therefore, the screen-grid voltage varies in phase with the control-grid voltage of dc amplifier V607. This increases the effectiveness of the amplifier in maintaining constant output voltage. HUM BAL control R614 is adjustable for presetting the amount of the ripple voltage fed back to the control grids of V605 and V606 to minimize the hum in the output, and with R615, represents the plate load for V607. Capacitor C606 assists in correcting the phase of the hum components of the cathode voltage to produce more complete hum cancellation in the output of the voltage regulator.

c. Filament, Oven-heater, and Tuning-Motor Circuits (fig. 37). Filament voltages of 6.3, 12.6, and 25.2 volts are required for the tubes in the receiver. Dial lamps I 201 and I 202 and filaments that require 25.2 volts are connected in parallel with the filament winding of T801. The filaments that require 6.3 or 12.6 volts are connected in series circuits. To prevent coupling of rf and if. signals through the filament circuits, C707 and C708 are used as filament bypass capacitors for V701 and V702 in the vfo subchassis, and C548 and C549 are employed in the if. subchassis. Resistor R301 limits the voltage across V210, V207, and V509 to approximately 18 volts. Resistor R565 limits the voltage across V507 and V510. To maintain constant heater voltage, and thus stabilize the operation of vfo tube V701 and bfo tube V508, ballast tube 3TF7 (RT512) is connected in series with the tube filaments. A potential of 25.2 volts is applied to vfo oven HR701 when OVEN switch S109 is set to ON. The oven is thermostatically controlled by switch S701 and serves to improve the stability of the vfo. Capacitor C705, connected across the contacts of switch S701, prevents radiation of noise impulses as a result of arcing at the contacts of the switch. As an aid to tuning the receiver throughout large frequency ranges, 25.2 volts for the operation of tuning motor B202 is applied when MOTOR TUNE switch S204 is operated. The field winding of the motor is in series with the armature during operation. A double-pole double-throw rotary switch is used as a reversing switch and, in its neutral (off) position, removes the motor from the circuit. When

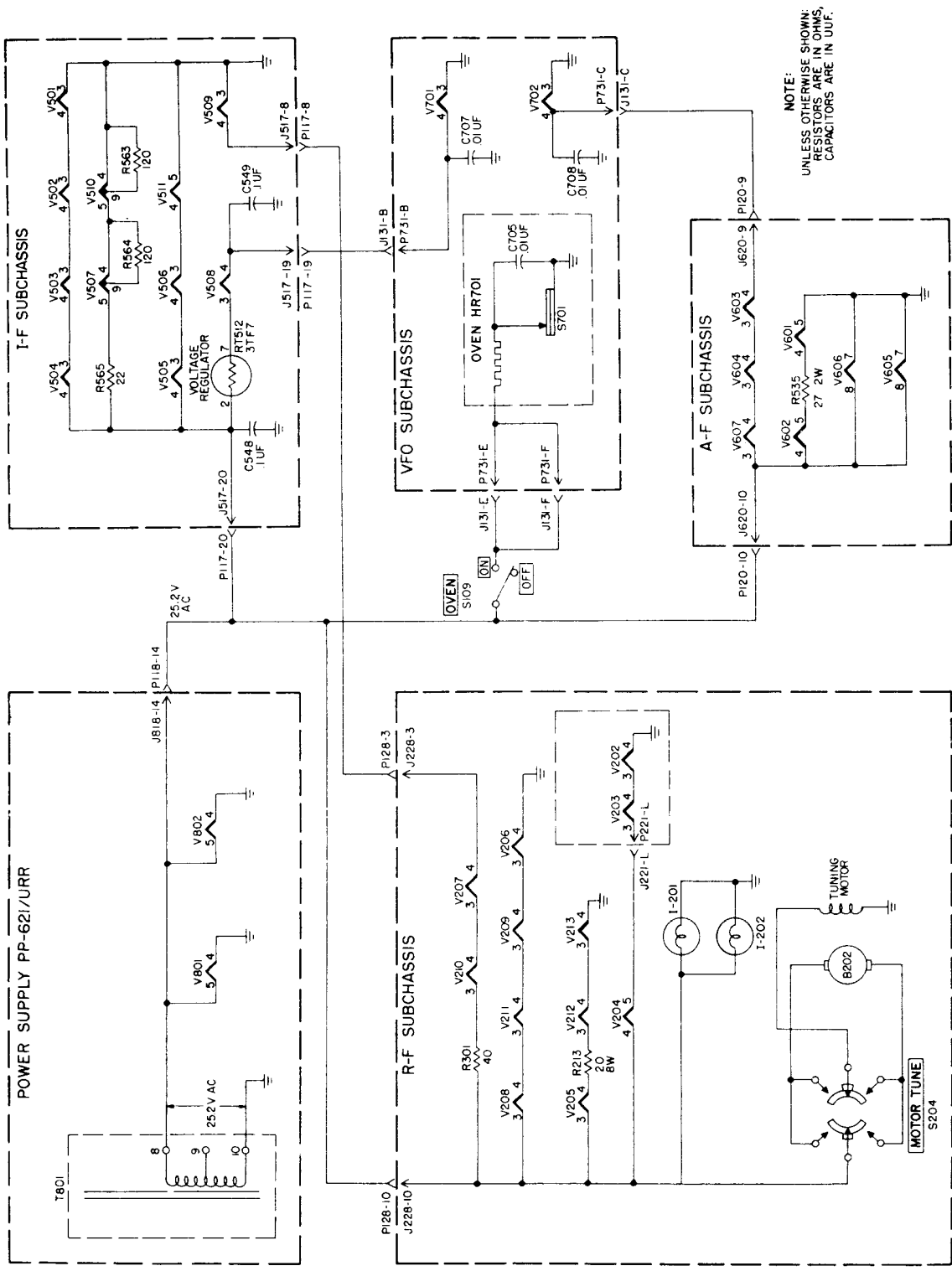

Figure 37. Filament, oven heater, and tuning motor circuits, schematic diagram.

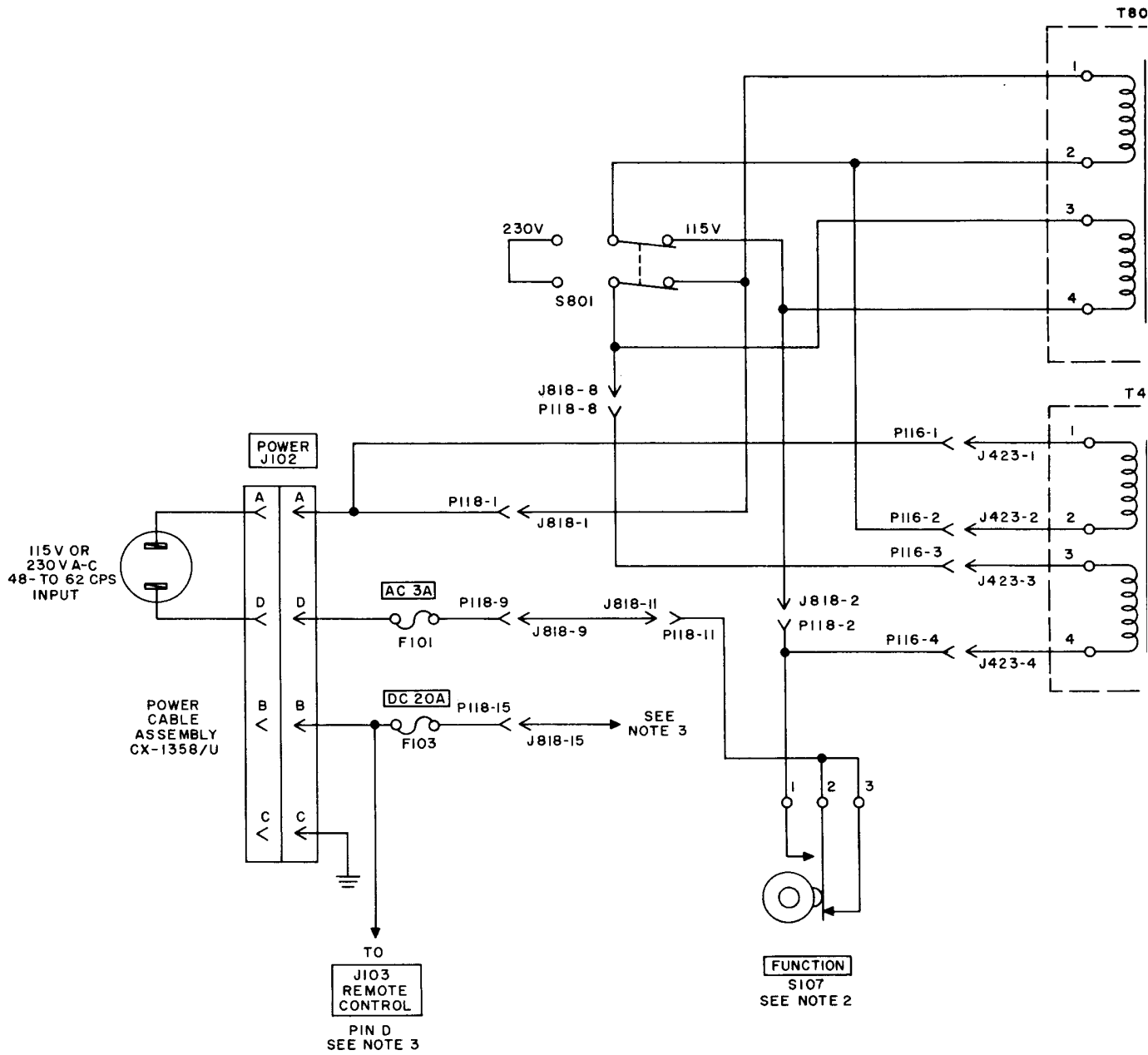
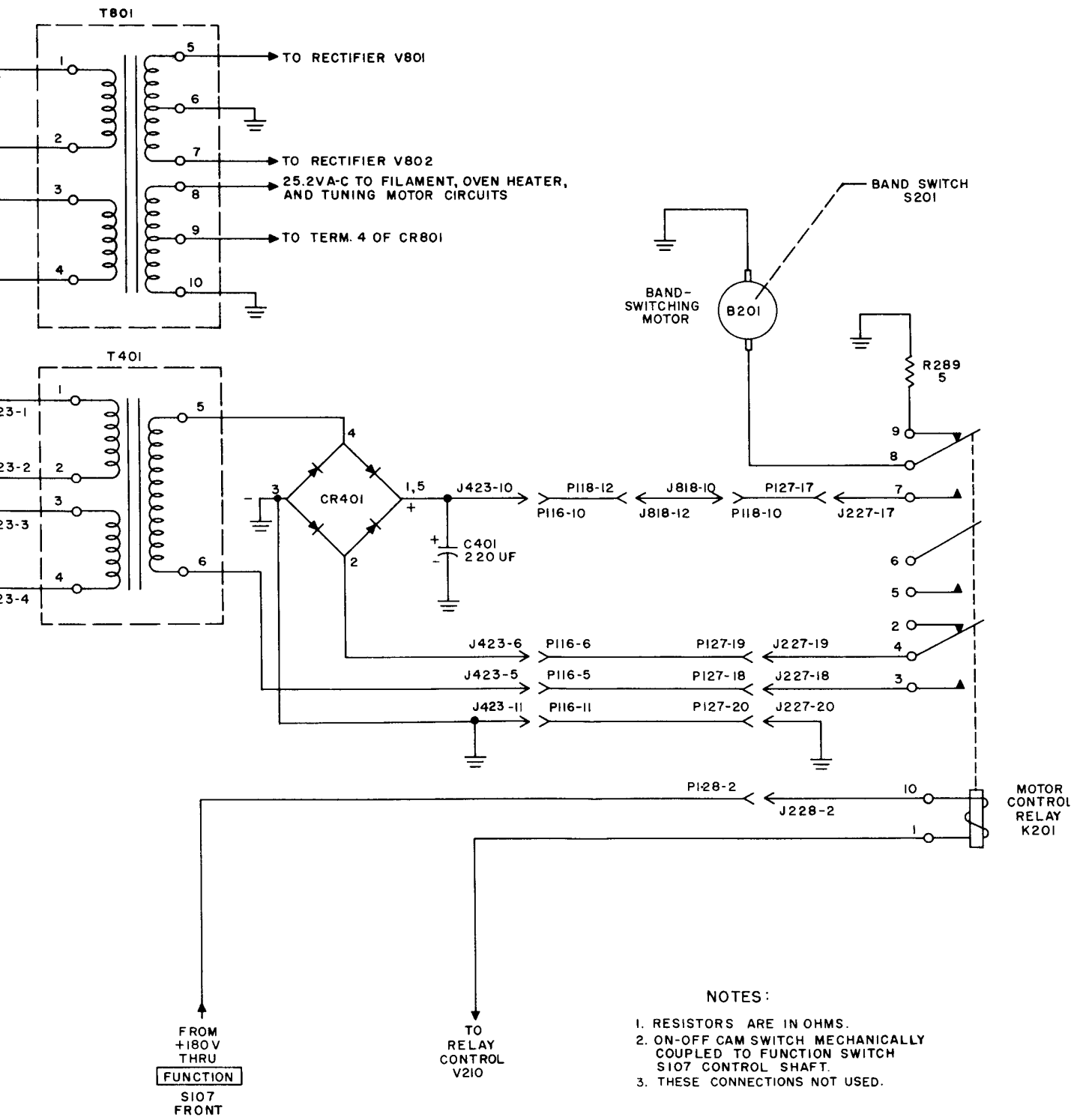

Figure 38. Band-switching motor power



Band-switching motor power supply, schematic diagram.

MOTOR TUNE switch S204 is rotated, the armature is connected in series with the field to produce rotation of the motor shaft in a given direction; if the switch is rotated in the opposite direction, the rotation of the motor shaft is reversed, because the phasing of the armature and field has been reversed.

d. Band-Switching Motor Power Supply (fig. 38).

- (1) The band-switching motor power supply operates from either 115 or 230 volts, 48 to 62 cycles, and supplies 28.5 volts dc for operation of band-switching motor B201. Primary power is connected to transformer T401 through switch S801, FUNCTION switch S107, and 3-ampere fuse F101, to terminals A and D of POWER J102 receptacle. Transformer T401 contains two separate primary windings which are effectively in parallel with those of transformer T801; this permits selection of either 115-volt or 230-volt operation by use of switch S801. Switch S801 connects the two primary windings in parallel for 115-volt operation and in series for 230-volt operation (*a* above). The output of the power supply is connected through P118 and J818 by a jumper between contacts 10 and 12 (of J818) in Power Supply PP-621/URR.
- (2) Secondary terminal 5 of transformer T401 is directly connected to one side of dry-disk rectifier CR401, and terminal 6 of T401 is connected through J423-5 and P116-5, P127-18 and J227-18, the contacts of motor control relay K201, J227-19 and P127-19, and P116-6 and J423-6, to the other side of rectifier CR401. Dc output of 28.5 volts is supplied through the contacts of relay K201 to band-switching motor B201 whenever relay K201 is energized to complete the secondary circuit to rectifier CR401. Capacitor C401 provides the necessary filtering to remove the 120-cycle ripple present in the output voltage.
- (3) Motor control relay K201 is energized through the operation of relay control tube V210 (par. 84). When relay K201 is energized, contacts 3 and 4 of the relay close to complete the secondary circuit of

T401 to rectifier CR401. The 28.5-volt dc potential is then applied from the rectifier through contacts 7 and 8 of relay K201 to the armature of band-switching motor B201. Band-switching motor B201 is mechanically coupled to band switch S201 to select the proper tuned circuits in the rf subchassis. When relay K201 is de-energized, contacts 3 and 4 open the secondary circuit of T401, and contacts 7 and 8 open to remove the dc supply from motor B201. When the relay is de-energized, contacts 8 and 9 of relay K201 close, and R289 is connected directly across the armature of B201 to provide dynamic braking. This action prevents the band-switching motor from coasting and overdriving the sections of band switch S201 beyond the desired switch position.

84. Relay Control V210

(fig. 39)

The relay control circuit uses a miniature triode tube, type 6C4W, in a grounded-grid application to energize motor control relay K201. The operation of the circuit is described in the following subparagraphs.

a. The control grid (pin 6) is grounded. Grid bias is developed across cathode resistor R288, which is connected between the cathode (pin 7) and ground. Resistor R288 and voltage-dropping resistor R287 in series form a voltage divider across the B voltage to provide fixed bias for the stage. Choke L304 and capacitors C293, C294, and C295 form an rf filter common to several circuits within the receiver. Plate (pin 1) potential is obtained from the 180-volt supply through the coil of motor control relay K201, J228-2 and P128-2, and FUNCTION switch S107.

b. The flow of current through series resistors R288 and R287 produces a bias voltage across R288 sufficient to bias relay control V210 to cut-off. Plate current does not flow and motor control relay K201 remains de-energized. The **FREQ RANGE** switch is connected to the cathode of V210, and selects one of two rf switching, motor-control, switch sections (S205A or S205B). These special switch sections, in turn, are electrically interconnected with seeking-switch sections K and L of band switch S201 (fig. 45). For the purpose of this discussion, it is assumed

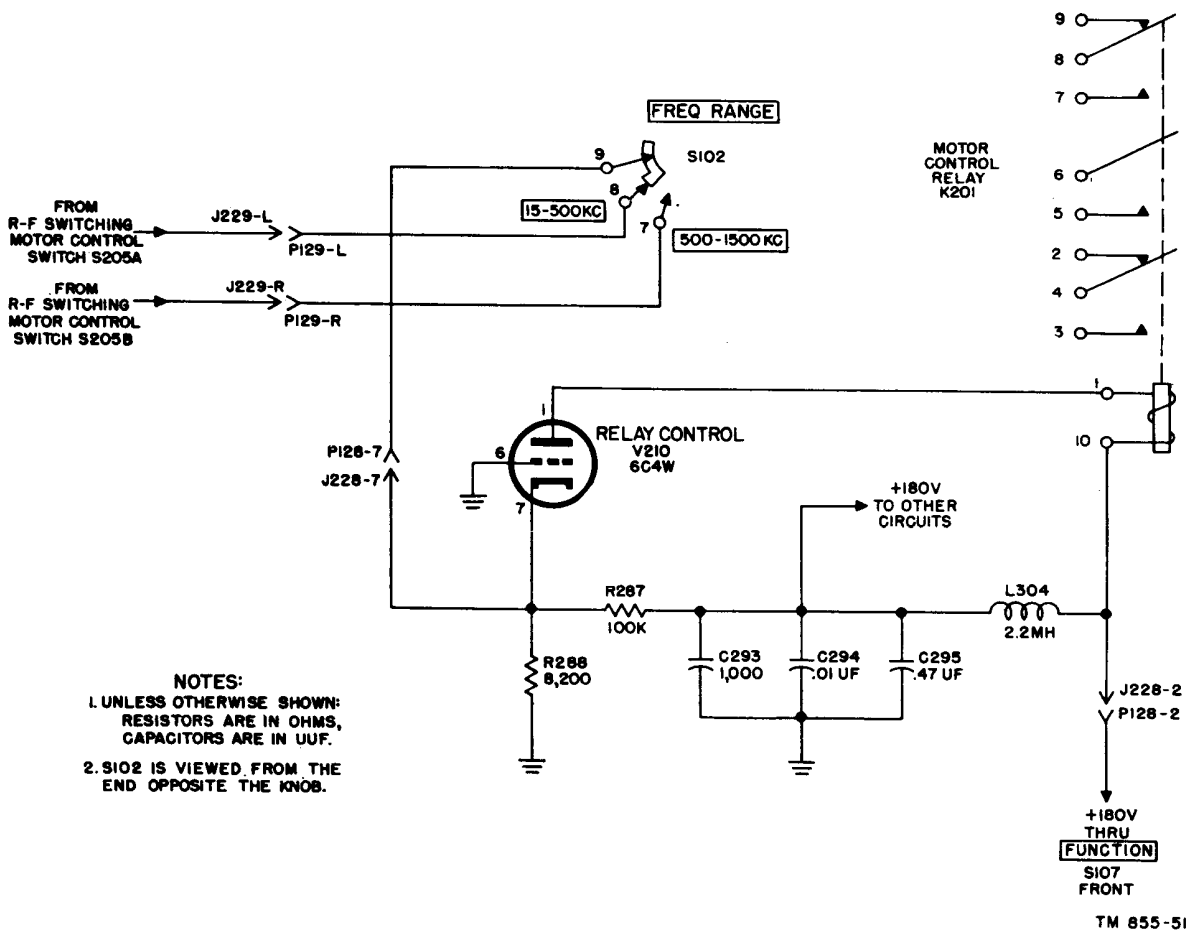

Figure 39. Relay control, schematic diagram.

that a circuit ground is connected in the relay control circuit at a remote point associated with the rf switching, motor-control, switch sections, S205A and S205B. When a circuit ground is connected to the cathode of V210 through the action of S205 and S102, the cutoff bias voltage normally developed across R288 is removed, and full B voltage appears across R287. Since the cathode is now at ground potential and bias voltage is removed, V210 conducts. Plate current which flows through the relay control tube also flows through the coil of motor control relay K201, and causes the relay to operate. When the circuit ground is removed from the cathode, bias voltage is again developed across R288, and causes the relay control tube to be biased to cutoff; plate current no longer flows and relay K201 becomes de-energized. The detailed operation of this circuit in association with the band-switching opera-

tion is covered in an analysis of the tuning system, in paragraph 89d (4).

85. FUNCTION Switch S107

(fig. 40)

a. The FUNCTION switch performs simple switching operations which affect the entire operation of Radio Receiver R-389/URR. Each mode of operation and each stage is affected by the position of the segments of the front and rear sections of this switch. A thorough understanding of the switch is essential for successful trouble shooting and maintenance.

b. Figure 40 shows the five positions of the FUNCTION switch. For clarification of its operation, only those circuits which are completed by the switch segments are identified. The primary power is applied to Power Supply PP-621/URR and to the band-switching motor power supply

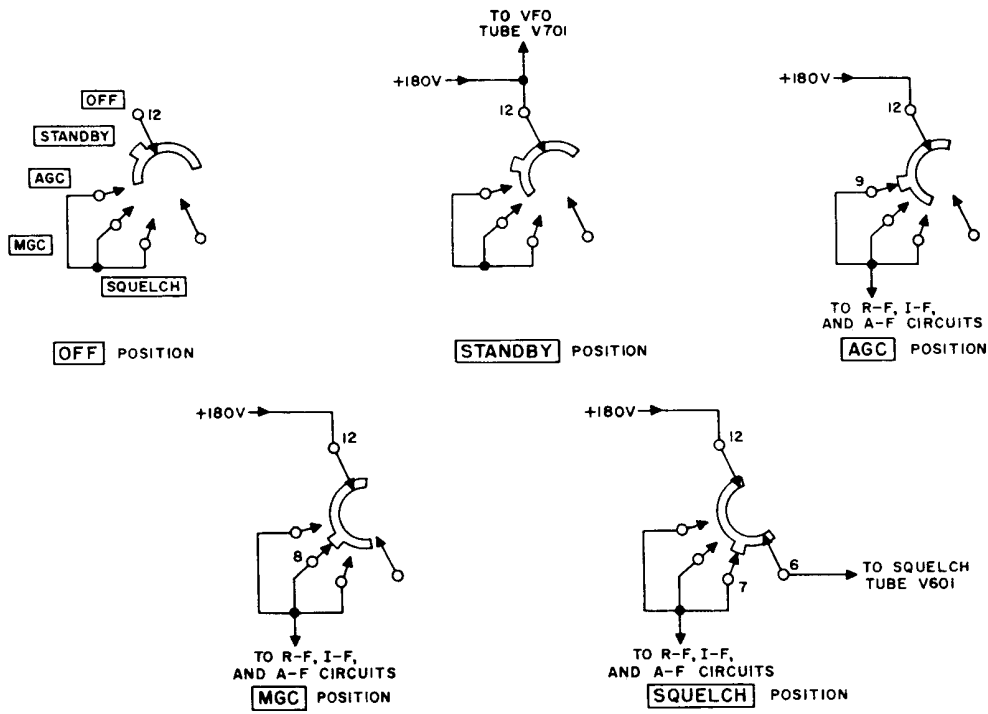

S107 FRONT

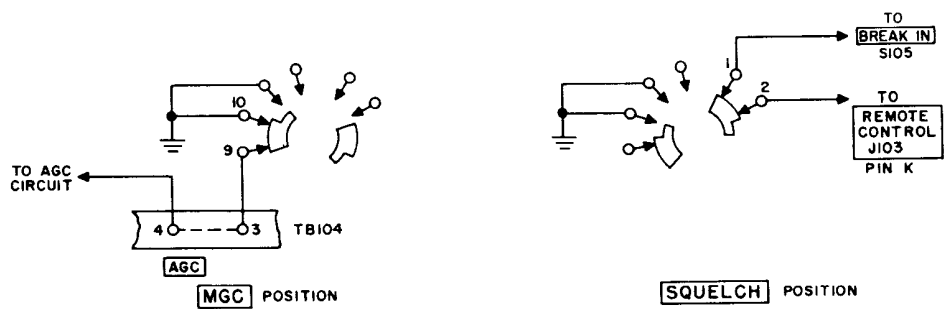
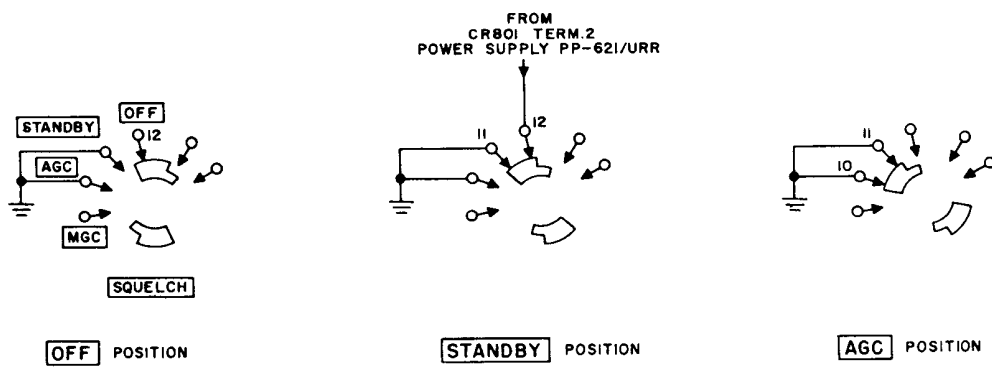

S107 REAR

TM 855-52

Figure 40. FUNCTION switch, schematic diagram.

through a cam-operated switch section at the front of S107 in all positions except OFF. The table below shows the circuits affected in each position

of the switch as related to the control-knob indication and also the completed contacts and circuits for the five positions of FUNCTION switch S107.

Position	Switch contacts made		Circuits
	Front	Rear	
OFF	None	None	Primary power is disconnected from the receiver.
STANDBY	None	11 to 12	Primary power is applied to the receiver. Terminal 2 of CR801 is grounded, applying 6 volts dc to antenna relay K101 to ground the antenna input at J105 and J106; 6 volts dc is also applied to break-in relay K602, which grounds the audio output of T601. 180 volts dc is applied only to the vfo subchassis (V701 and V702).
AGC	12 to 9	None	180 volts dc is applied to the rf, if, and af stages. Agc voltage at contact 9 (rear) is not grounded. Ground is removed from terminal 12 (rear), which is connected to terminal 2 of CR801, and antenna relay K101 and break-in relay K602 are de-energized.
MGC	12 to 8	10 to 9	The conditions for the MGC position are the same as for the AGC position, except that the agc bus is grounded through contacts 9 and 10 (rear).
SQUELCH	12 to 7, 12 to 6	1 to 2	The conditions for the SQUELCH position are the same as for the AGC position, except that 180 volts dc is applied to squelch tube V601 through contact 6 (front). The carrier-control circuit of squelch relay K601 is made available through BREAK IN switch S105, contacts 1 and 2 (rear), to REMOTE CONTROL receptacle J103, pin K (par. 86).

86. Control Circuits

(fig. 41)

When using Radio Receiver R-389/URR in connection with a transmitter, it is necessary to disable certain receiver circuits during transmission to prevent damage and to silence the receiver. When FUNCTION switch S107 is set to STANDBY, segment 1 of S107 (rear) is connected across contacts 11 to 12 (fig. 41), and a ground is applied to terminal 2 of rectifier CR801; thus, antenna relay K101 and break-in relay K602 in parallel are energized. The operation of FUNCTION switch S107 is described in paragraph 85. The movable contacts of antenna relay K101 are connected to ground; therefore, the contacts short-circuit the antenna input at receptacle J105 or J106, and no rf energy can enter the input circuits of Radio Receiver R-389/URR. When FUNCTION switch S107 is set to AGC, MGC, or SQUELCH, break-in relay K602, in parallel with antenna relay K101, may be energized by applying a ground connection. Auxiliary equipment connected to terminal 5 of TB104 or pin B of REMOTE CONTROL receptacle J103 provides this ground connection if BREAK IN switch S105 is

set to ON. When BREAK IN switch S105 is in the ON position, connection is made across contacts 7 and 9, completing the break-in circuit to terminal 2 of CR801. An external ground, connected at either terminal 5 of TB104 or at pin B of J103, will energize relays K101 and K602. The antenna input and audio output are short-circuited to ground, and Radio Receiver R-389/URR is disabled during the operation of a local transmitter connected for remote operation. With the BREAK IN switch set to the OFF position, audio is applied from the line audio channel to pins A and J of REMOTE CONTROL receptacle J103 through switch contacts 5 and 6, and 11 and 12 of S105; this permits remote net operation. To permit carrier-control operation, FUNCTION switch S107 must be set to SQUELCH (contacts 1 and 2 connected by means of segment 2), and BREAK IN switch S105 must be set to OFF (contacts 2 and 3 connected). The carrier-control line from contact 3 of squelch relay K601, through contacts of S105 and S107, is terminated at pin K of REMOTE CONTROL receptacle J103. In the SQUELCH position, with no signals being received, squelch relay K601 is energized and contacts 1 and 2 (K601) ground the audio at trans-

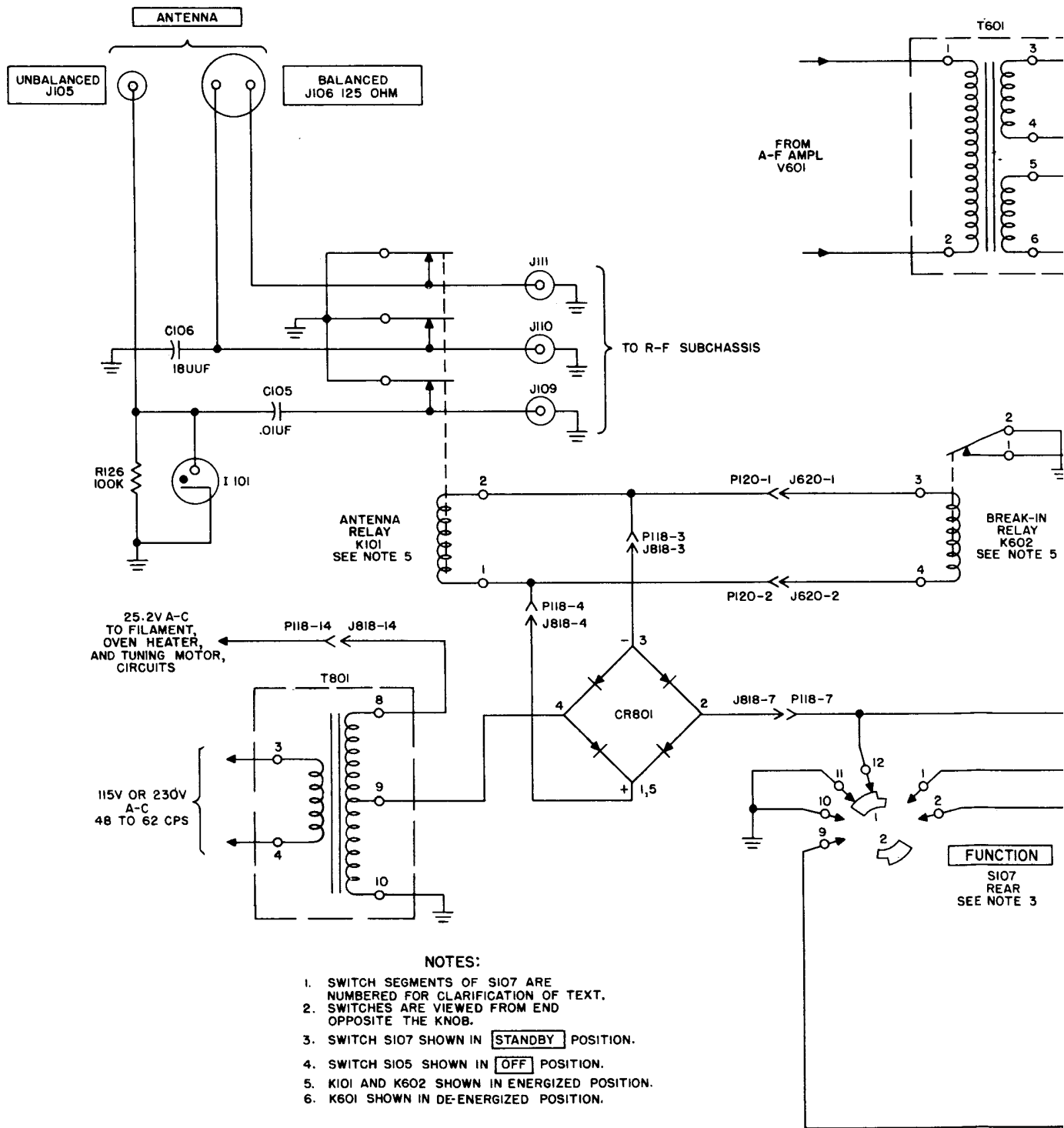
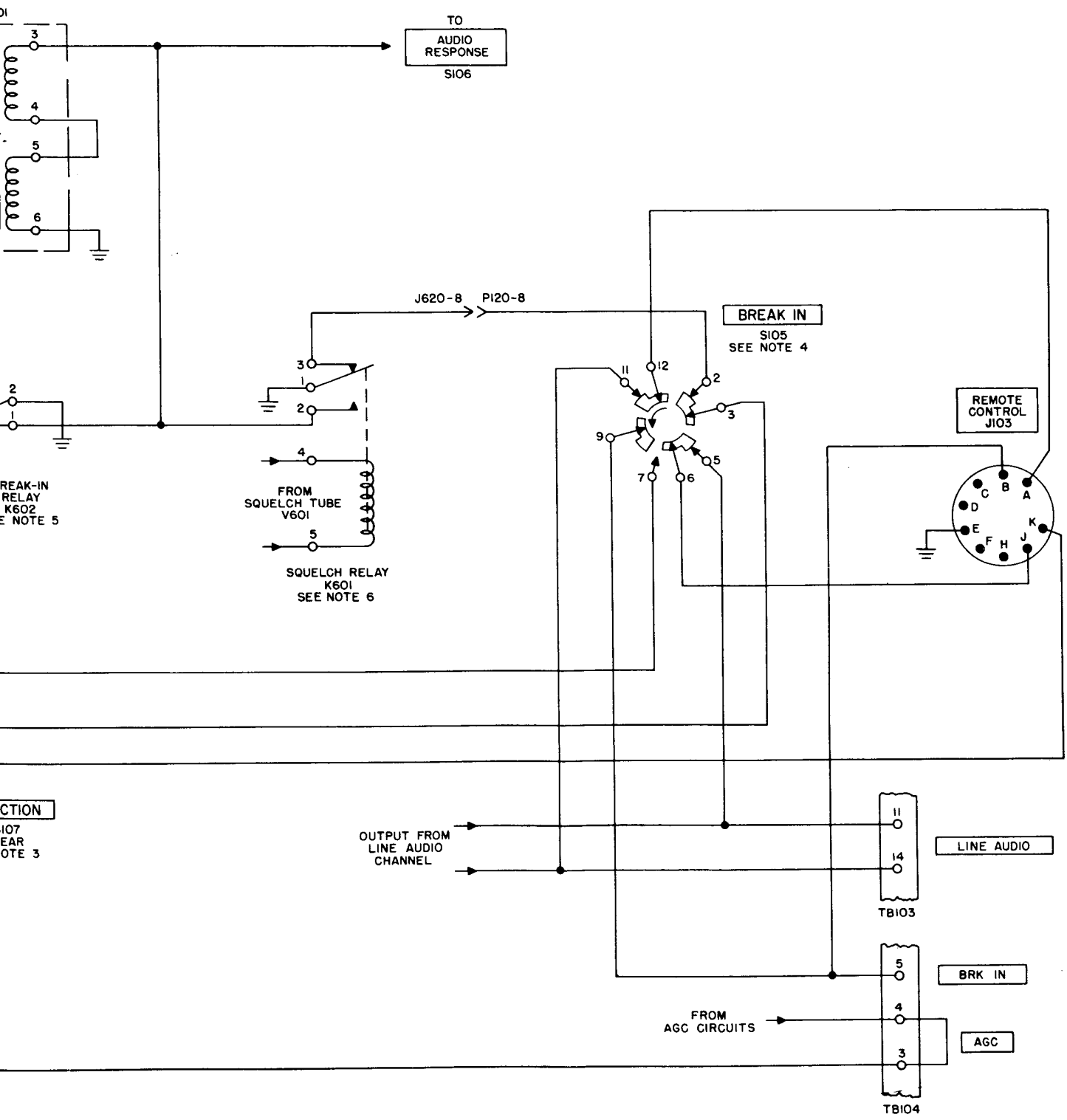

Figure 41. Break-in circuit



SECTION
 IO7
 EAR
 NOTE 3

break-in circuit. schematic diagram.

former T601 to silence the audio output of the receiver. Contact 3 of squelch relay K601 is open. When a signal is received, squelch relay K601 is de-energized (par. 82), contacts 1 and 2 open to permit audio output, and the carrier-control line at contact 3 of K601 is grounded to key associated

equipment. When BREAK IN switch S105 is set to ON, the carrier-control line is disabled by opening contacts 2 and 3, which are in series with the lead from contact 3 of squelch relay K601, through contacts 1 and 2 of S107, to pin K of REMOTE CONTROL receptacle J103.

Section III. ANALYSIS OF TUNING SYSTEM

87. General Principles of Operation

The mechanical tuning system of Radio Receiver R-389/URR controls the permeability tuning and switching elements to provide linear tuning of the receiver over the entire frequency range of 15 to 1,500 kc in two manually selected ranges. The low range of 15 to 500 kc is covered in five bands which use five sets of tuned circuits, and the high range of 500 to 1,500 kc is covered in two bands which use two sets of tuned circuits. The frequency selected is indicated on a counter-type dial, which shows the frequency directly in kc.

a. The **FREQ RANGE** switch, S102, is a two-position switch which is mechanically linked to a three-section wafer-switch, S203. Control positions are marked 15-500 KC, and 500-1,500 KC. Switch S102 selects one of two sections of band-switching motor-control switch S205 for the automatic band-switching operation, and S203 selects one of two sets of tuned circuits in the buffer and first-mixer injection circuits. As the **FREQ RANGE** switch is operated, a mask that covers the frequency counterdials is moved to display the proper set of numbers associated with the selected frequency range.

b. The **FREQ CHANGE** control positions powdered-iron slugs within the coils of the antenna, first and second rf amplifiers, first mixer, vfo, buffer, and first-mixer injection circuits: this changes the resonant frequency of each tuned circuit. The frequency to which the receiver is tuned is indicated directly in kc on a countertype dial which is coupled to the mechanical tuning system. The **FREQ CHANGE** control also drives band-switching motor-control switch S205, which functions to govern the automatic selection of one of seven sets of tuned circuits covering the frequency range of 15 to 1,500 kc. To cover a large span of frequencies in less time than is required through manual rotation of the **FREQ CHANGE** control, motor tuning is provided. **MOTOR TUNE**

switch S204 assists the operator in this tuning operation by controlling the operation and direction of rotation of a tuning motor which drives the mechanical tuning system.

c. Band switching is done automatically by a motor-driven band switch, S201. As the **FREQ CHANGE** control is rotated throughout the range of 15 to 500 kc, section A of band-switching motor-control switch S205 selects one of five sets of permeability tuned circuits which are driven by the **FREQ CHANGE** control. When the 500- to 1,500-kc range is in use, switch section S205B selects one of two sets of permeability tuned circuits.

88. Functional Analysis

This analysis will provide information for the repairman who might be faced with the problem of making repairs or adjustments on the tuning system. A careful study should be made of the material in paragraphs 119 and 120 relating to mechanical alignment. Figures 42, 43, 44, and 45 show simplified block diagrams of the three main functional groups which comprise the mechanical tuning system; these block diagrams are discussed in *a* through *c* below and in paragraph 89.

a. Reference to the block diagram (fig. 42) shows the stages controlled by the **FREQ RANGE** control. As shown on the block diagram, **FREQ RANGE** switch S102 is mechanically linked to a three-section two-position wafer switch (S203). The action of switch S203 is such that the unused tuned circuit is shunted by a 100-ohm resistor to prevent interaction with the selected circuit. In the 15-500 KC position of the **FREQ RANGE** switch, tuned circuit Z218 is selected for the plate circuit of buffer V702, Z219 is selected for the plate circuits of injection mixers V212 and V213, and Z215 is selected for the plate circuit of output coupler V209. For this condition, the fundamental frequency of vfo V701 is amplified by buffer V702, and tuned circuit Z218 tunes throughout

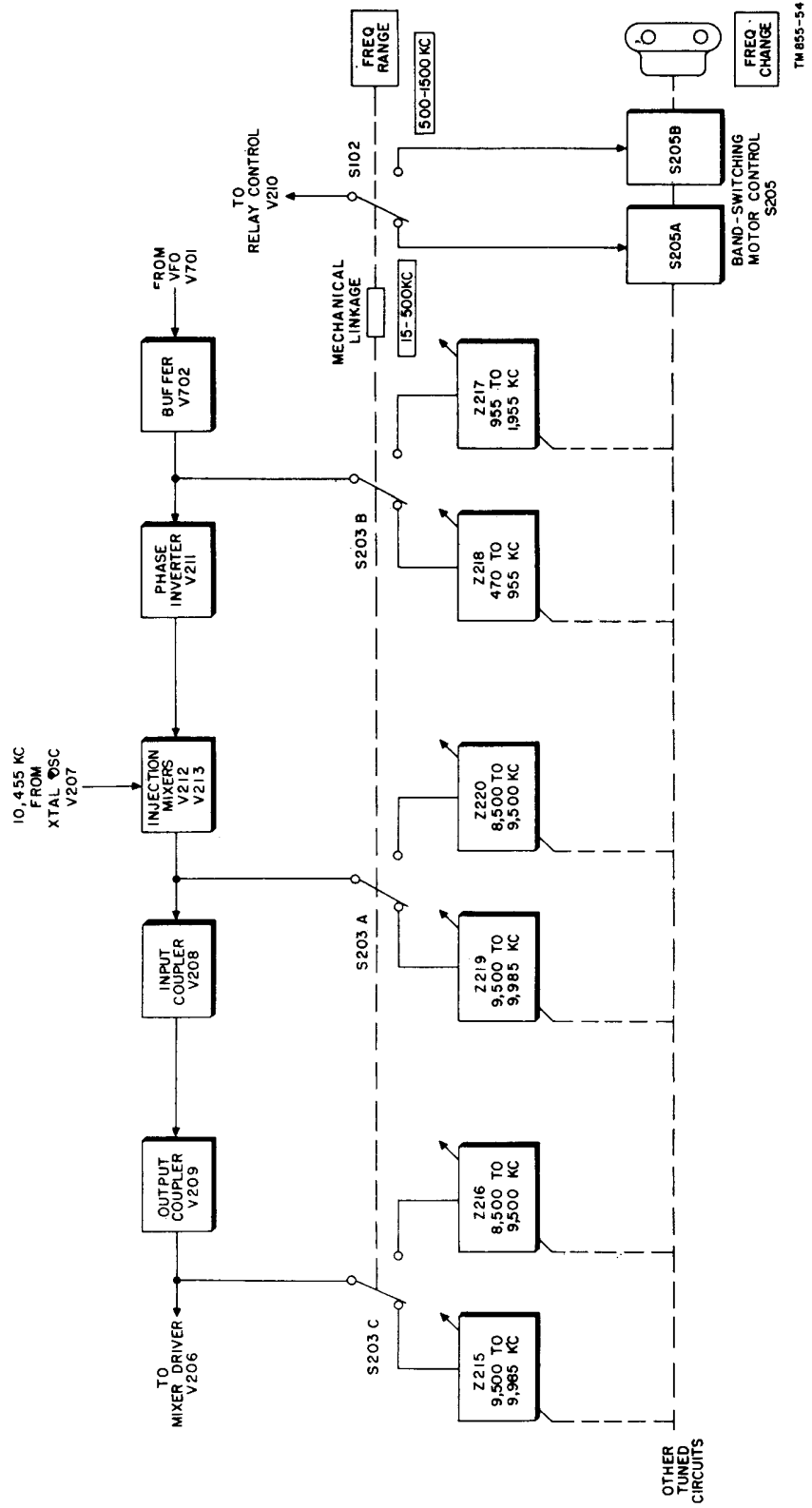
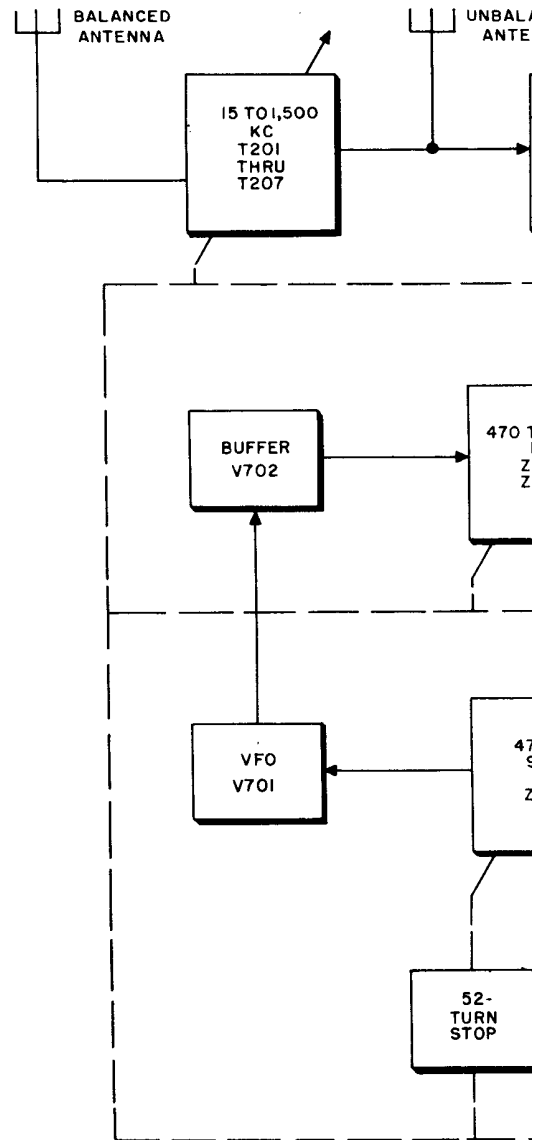

Figure 42. FREQUENCY RANGE switch with associated stages, block diagram.



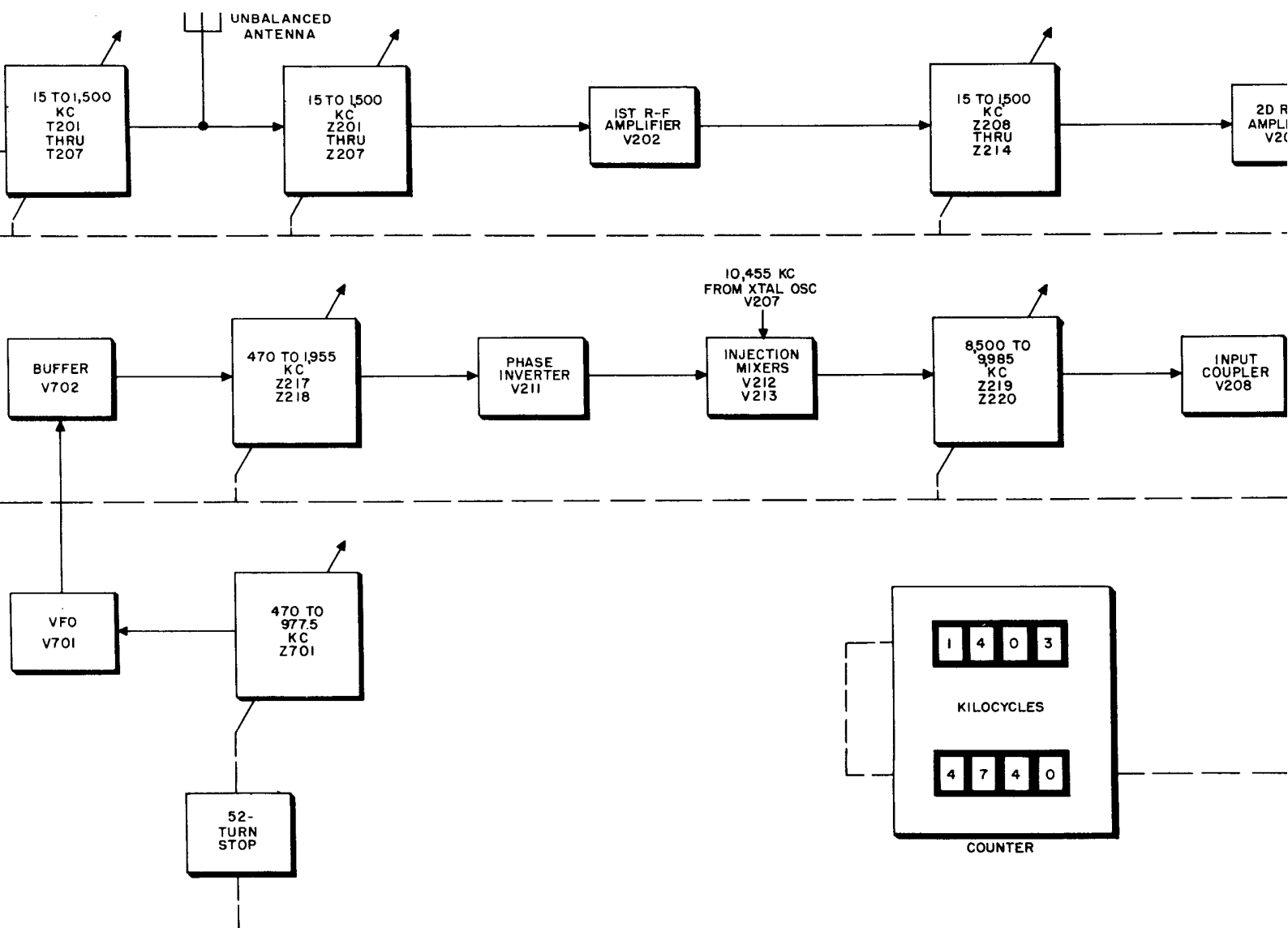
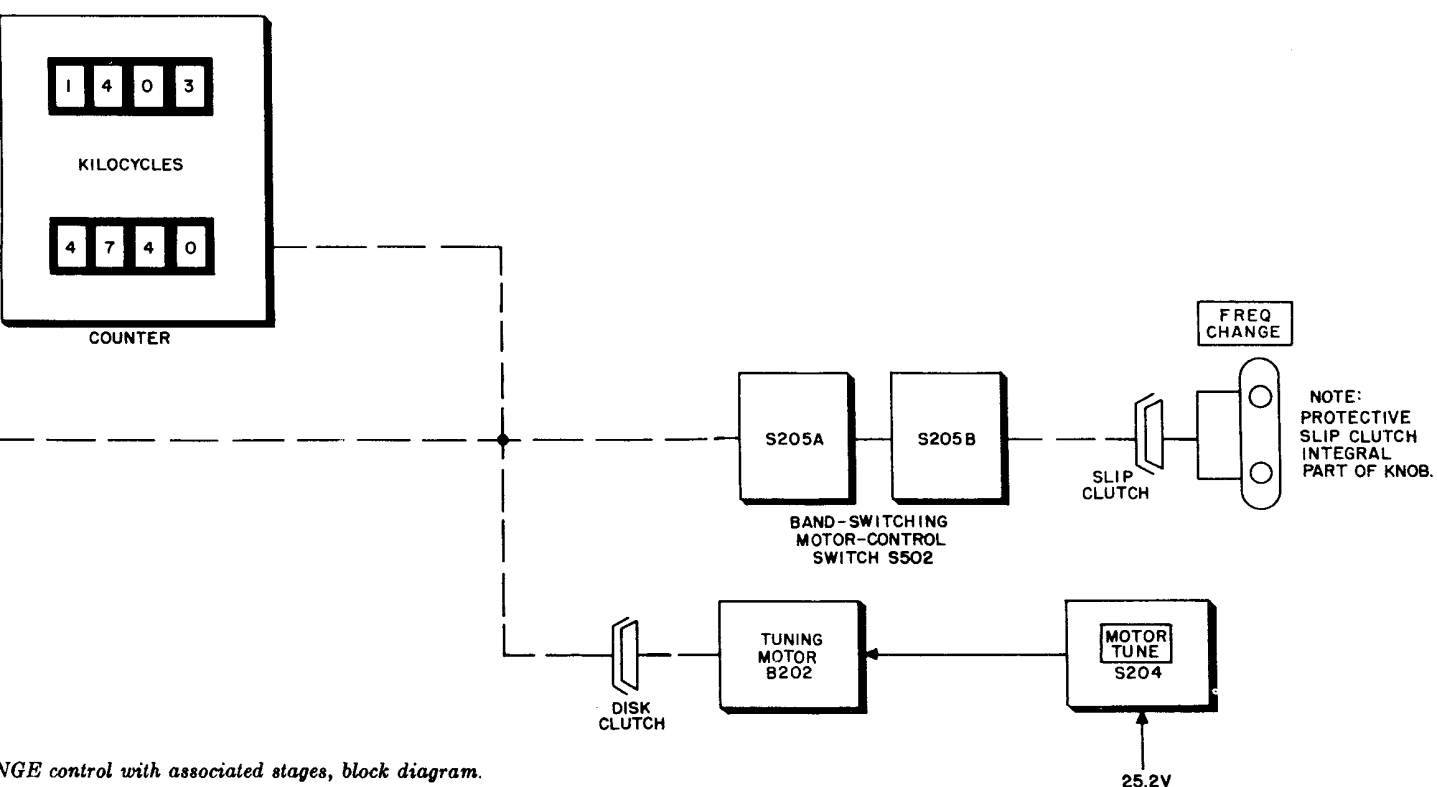
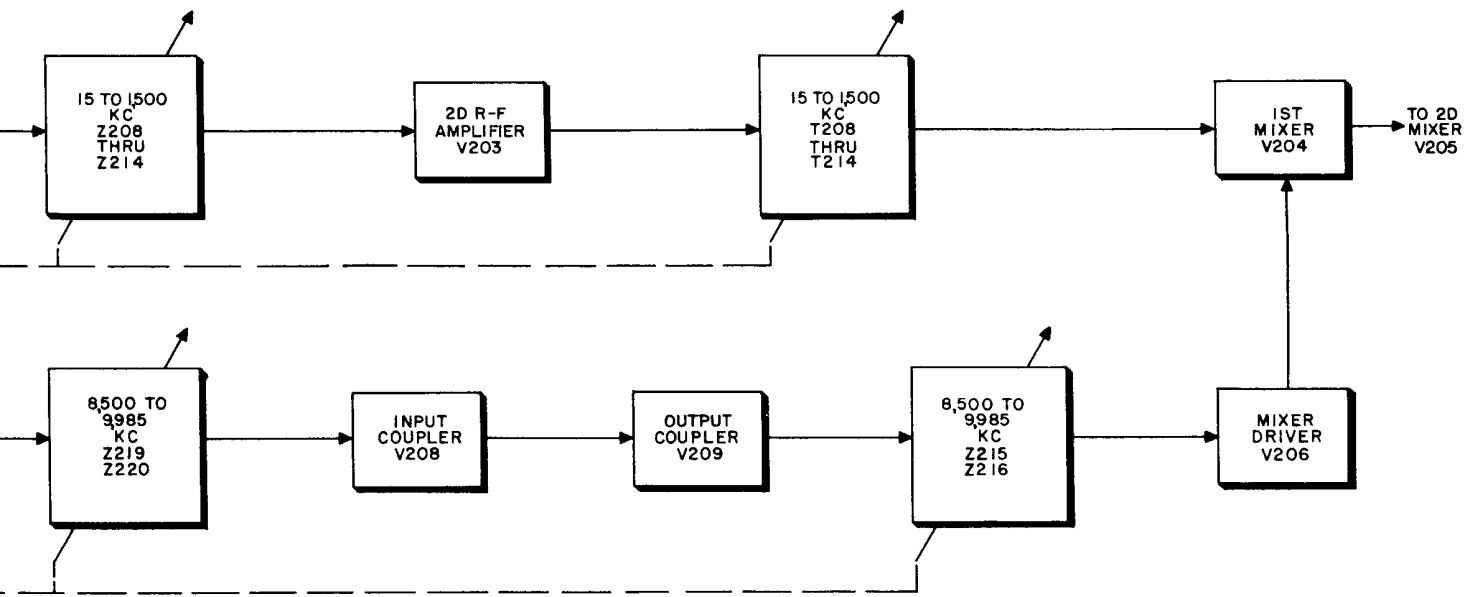

Figure 43. *FREQ CHANGE control with associated stages, block diagram.*



Tuning control with associated stages, block diagram.

a range of 470 to 955 kc. As explained in paragraph 62, the frequencies present in the plate circuit of injection mixers V212 and V213 are the difference-frequencies between crystal oscillator V207 and that which is supplied through phase inverter V211. In this case, tuned circuit Z219, in the plate circuit of V212 and V213 tunes throughout a range of 9,500 to 9,985 kc. Tuned circuit Z215, in the plate circuit of output coupler V209, also tunes throughout the range of 9,500 to 9,985 kc. When the **FREQ RANGE** switch is set to the 500-1500 KC position, tuned circuit Z217 is selected for buffer V702, Z220 is selected for injection mixers V212 and V213, and Z216 is selected for output coupler V209. For this condition, buffer V702 amplifies the second harmonic of vfo V701, and tuned circuit Z217 tunes throughout a range of 955 to 1,955 kc (the vfo fundamental frequency range is 477.5 to 977.5 kc). Tuned circuit Z220, in the plate circuit of V212 and V213, tunes throughout a range of 8,500 to 9,500 kc. Tuned circuit Z216, in the plate circuit of output coupler V209, also tunes through the range of 8,500 to 9,500 kc. Tuned circuits Z215 through Z220 are permeability tuned by powdered-iron cores suspended on mechanical racks; the position of the core within the coils of each tuned circuit is determined by the position of the associated rack, which, in turn, is controlled by the **FREQ CHANGE** control. Other tuned circuits within the receiver are similarly controlled by the **FREQ CHANGE** control. **FREQ RANGE** switch S102 connects relay control V210 to S205A in the 15-500 KC position, and to S205B in the 500-1500 KC position.

b. The **FREQ CHANGE** control operates a system of mechanical racks to position powdered-iron cores attached to the racks within coils of the receiver tuned circuits. The block diagram (fig. 43) shows the stages controlled by the **FREQ CHANGE** control. The antenna, first and second rf amplifiers, first mixer, buffer, and first-mixer injection circuits are tuned by means of powdered-iron cores attached to mechanical racks controlled by the **FREQ CHANGE** control. The vfo tuned circuit, Z701, is tuned by a threaded powdered-iron core mounted on a rotating lead screw, which is coupled to the **FREQ CHANGE** control through a 52-turn mechanical stop. The stop mechanism serves to limit the travel of the tuning core within tuned circuit Z701 by preventing further rotation of the lead screw, as well as to lock

the entire mechanical tuning system at the extreme limits of tuning. The **FREQ CHANGE** knob contains a protective slip clutch as an integral part of the knob and prevents damage to the mechanical system as a result of knob rotation when the mechanical limit of the tuning system is reached. A countertype dial indicates the frequency to which the receiver is tuned directly in kc. A mask, controlled by the **FREQ RANGE** switch, covers the set of counterdials not in use and allows the numbers associated with the frequency range in use to be exposed to view. Band-switching motor-control switch S205 governs the selection of the proper set of rf coils, within the range of the receiver, as the **FREQ CHANGE** control is rotated. Tuning motor B202 may be energized to assist the operator in tuning through a large range of frequencies rapidly. **MOTOR TUNE** switch S204 applies 25.2 volts to tuning motor B202, and simultaneously activates a clutch to engage the motor with the mechanical tuning system. If the mechanical limits of the tuning system are reached before the tuning motor is disabled, the clutch will slip to prevent damage to the tuning system.

c. The band-switching system employed in Radio Receiver R-389/URR is illustrated in the block diagram (fig. 44). When **FREQ RANGE** switch S102 is operated, the required set of coils is automatically switched into the circuits by sections A through J of a seven-position rf band switch, S201. Rf band switch S201 is driven by band-switching motor B201. Switch section S205A consists of five segments located about the circumference of this special switch section, with the wiper contact connected to one terminal of **FREQ RANGE** switch S102. Each of the five segments is connected to a corresponding contact on seeking-switch section S201K. Switch section S205B consists of two segments, with the wiper connected to a second terminal on S102, and each segment is connected to a corresponding contact on seeking-switch section S201K. As the **FREQ CHANGE** control is rotated from a given frequency to a new frequency that requires a different set of rf coils, the wiper contacts of band-switching motor control switch S205 are also rotated. As the wiper contact of S205 moves from one segment to an adjacent segment, corresponding to the next desired set of rf coils, a ground connection is obtained through seeking-switch section S201K; this places the cathode of relay control V210 at

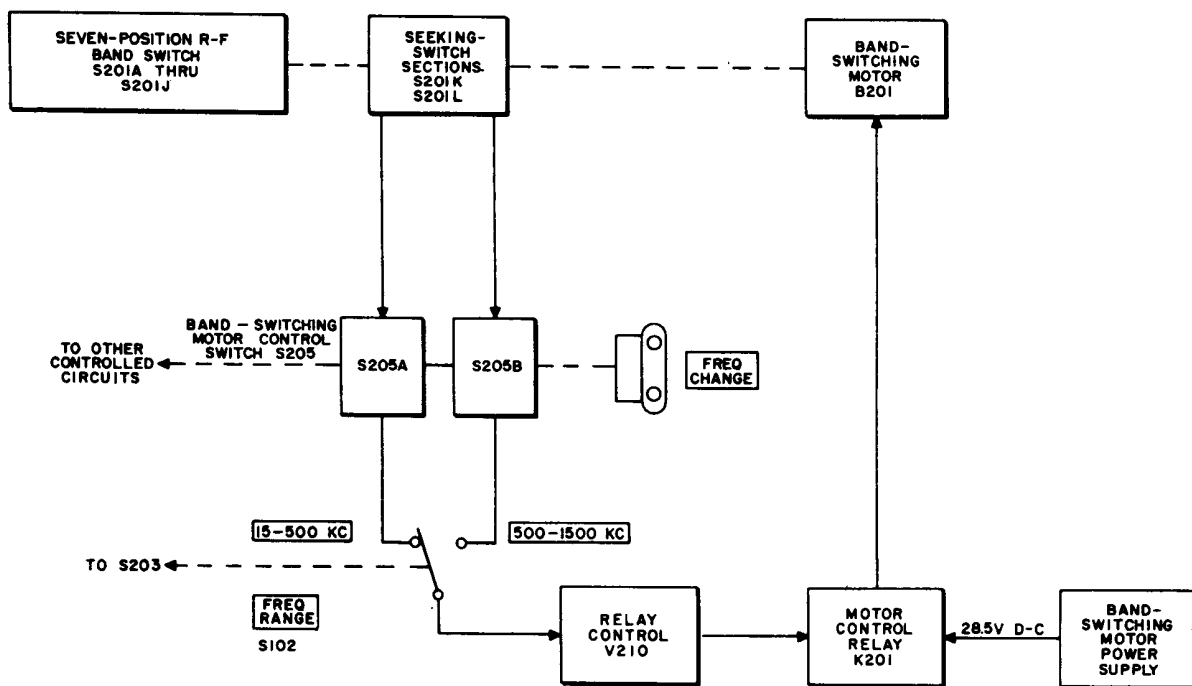

TM 855-56

Figure 44. Band-switching system, block diagram.

ground potential (par. 84). With bias removed, V210 conducts, to energize motor control relay K201. A potential of 28.5 volts dc, obtained from the band-switching motor power supply (par. 83), is applied through the contacts of K201 to band-switching motor B201. Motor B201 operates to drive rf band switch S201, and in so doing, rotates the seeking-switch sections. When seeking-switch section S201K aligns with the position corresponding to the proper set of rf coils, the ground is removed from the cathode of relay control V210, normal cutoff bias returns, and motor control relay K201 is de-energized. Dynamic braking is applied to band-switching motor B201 when relay K201 is de-energized (par. 83d); this prevents any possibility of the band-switching system overshooting the proper switch position.

89. Detailed Analysis

Information contained in *a* through *d* below will aid in understanding the function and connection of the three main groups which make up the mechanical and electrical tuning system. The exploded view of the tuning system (fig. 45) illustrates the mechanical parts and their relationship to each other. The placement of the various gears involved in the mechanical system has been illustrated from the standpoint of clarity and as-

sociation with related text matter, and does not necessarily indicate the exact physical placement within the equipment. Gears that are physically mounted together are shown as operating from a common shaft to illustrate more clearly the mechanical action involved. The numbers that appear on the gears of the exploded view are used to indicate the number of teeth, and reference symbols assigned to the parts are used for identification purposes in the related text. Band designations have been employed to identify the racks that support the tuning cores of the rf coils as follows:

Band	Approximate frequency range (kc)
A-----	15-27
B-----	27-55
C-----	55-117
D-----	117-242
E-----	242-500
F-----	500-865
G-----	865-1,500

Note. In the discussion of the electrical functions of the band-switching system, figure 46 is simplified to eliminate plugs and receptacles which interconnect the various parts. To assist in the explanation, band designations mentioned above have been assigned to the segments and contacts of the switches.

a. FREQ RANGE Control (fig. 45).

- (1) The FREQ RANGE control-shaft assembly is mounted on the front panel of the receiver and includes a two-position stop, a wafer switch for band-switching motor-control selector S102, and a lever for operation of the frequency-counter mask through a rod and lever linkage.
- (2) Band-switching motor-control selector S102 is a two-position wafer switch which selects one of two sections of band-switching motor-control switch S205.
- (3) The FREQ RANGE control-shaft assembly is attached to an extension shaft, which is connected to a system of levers and rods within the rf subchassis to operate buffer and first-mixer injection circuit band switch S203.

b. FREQ CHANGE Control (fig. 45).

- (1) As the FREQ CHANGE control is rotated, the vfo tuning shaft is rotated through a 4 to 1 reduction gear train comprised of spur gear O 228, antibacklash gears O 217 and O 218, and O 224 and O 225, and spur gear O 227 attached to the vfo drive shaft. An Oldham coupler is used to correct slight misalignment between the vfo drive shaft and the vfo tuning shaft.
- (2) A 52-turn stop mounted on the vfo subchassis limits the number of turns that the shaft can be rotated and serves to set the mechanical limits of the tuning system. The stop mechanism includes a single-notch stop washer rigidly fastened to the vfo tuning shaft, a dog which engages the single-notch stop washer, and a double-notch stop washer which is driven from the vfo tuning shaft through a reduction gear train comprised of spur gears O 702 and O 703. The rectangular tooth at the tip of the dog engages the single-notch stop washer, and a follower (triangular tooth) rides on the double-notch stop washer. A spring applies torque to the dog and forces the follower to bear upon, and engage, the notches of the double-notch stop washer. During operation of the FREQ CHANGE control, the double-notch stop washer is rotated and its notches are engaged repeatedly by the follower of the dog. The

dog is actuated whenever a notch is encountered, and the rectangular tooth is permitted to come in contact momentarily with the edge of the single-notch stop washer. When the rectangular tooth does not fall in the notch of the single-notch stop washer, the shafts continue to rotate and the dog is raised through the action of the follower upon the double-notch stop washer. The relative rate of rotation of the stop washers is fixed in such a manner that the dog engages the notch in the single-notch stop washer only after the vfo tuning shaft has been rotated in either direction to the extent required to cover the fundamental frequency range of the oscillator. Fifty-two turns of the shaft are required to tune the oscillator throughout its complete range. When the limit of tuning has been reached, the follower drops into a notch of the double-notch stop washer and consequently allows the rectangular tooth of the dog to fall and engage the notch of the single-notch stop washer; this locks the vfo tuning shaft to prevent further rotation. Rotation of the vfo tuning shaft in the reverse direction is possible at this time because the notch of the single-notch stop washer is wider than the tooth of the dog. As the direction of the shaft and single-notch stop washer is reversed, the double-notch stop washer raises the dog through action of the follower; this permits the tooth of the dog to raise and clear the opposite edge of the notch in the single-notch stop washer.

- (3) A protective slip clutch within the FREQ CHANGE knob protects the manual tuning gear train. When the 52-turn stop is engaged, further rotation in the direction of travel causes the clutch to slip and prevents the application of excessive torque which would cause damage to the gears. Adjustment of this clutch is provided by four screws which are accessible through holes in the fluted flange of the knob.
- (4) As the FREQ CHANGE control is rotated, worm O 245, mounted on the vfo drive shaft, rotates to drive antibacklash worm wheels O 244 and O 248 to provide

a reduction of 51 to 1 for operation of band-switching motor control S205. This gear ratio causes the rotors of S205 to cover less than 360° rotation between the limits established by the 52-turn stop mechanism. Further discussion of the operation of band-switching motor control S205 will be found in *d* below.

- (5) Frequency counter M201 contains two sets of numbered wheels. The lower set of numbered wheels, for the 15- to 500-kc range, are driven from the vfo drive shaft through a 1 to 10 stepup gear train comprised of spur gear O 226, antibacklash gears O 235 and O 236, and O 233 and O 234, spur gear O 232, antibacklash gears O 229 and O 230, and bevel gears O 231 and O 246. The upper set of numbered wheels for the 500- to 1500-kc range are driven from the lower set through a 5 to 1 reduction gear train mounted at the side of the counter case. The DIAL LOCK mechanism operates to clamp antibacklash gears O 233 and O 234, which, in turn, prevent movement of the entire mechanical tuning system. The lower set of counters of the counter dial (15-1,500 kc) has three black wheels and one red wheel. The black wheels show the frequency in kilocycles and the red wheel shows tenths of a kilocycle. The counter case has a decimal point located between the third and fourth (red) counter wheels.
- (6) The two parallel line shafts which operate the lead screws of the nine racks which make up the rf tuning assembly are driven at right angles from the rf drive shaft through two sets of helical gears, O 202 and O 210, and O 203 and O 211. The rf drive shaft is driven from the vfo drive shaft through a 1 to 10.25 stepup gear train which comprises spur gear O 226, antibacklash gears O 222 and O 223, spur gear O 221, antibacklash gears O 214 and O 215, and O 213 and O 216, and spur gear O 212. An Oldham coupler is used between the short shaft of spur gear O 212 and the rf drive shaft to correct slight misalignment in the axial positions of the two shafts. The

two parallel-line shafts each have eight worms and one helical gear (A-band rack) for driving the lead screws of the nine racks. The lead screws for the A-band are clamped to helical gears O 337 and O 338; the remaining lead screws for the eight other racks are clamped to worm wheels which mesh with worms mounted on the two parallel-line shafts. The front-line shaft consists of worms O 206, O 220, O 249, O 207, O 208, O 284, O 205, and O 209, and helical gear O 204. These gears mesh with worm wheels O 353, O 351, O 349, O 347, O 345, O 343, O 341, and O 339 and helical gear O 337 mounted on the front lead screws of the tuning racks. The rear-line shaft consists of worms O 287, O 286, O 285, O 289, O 290, O 288, O 293, and O 292 and helical gear O 291. These gears mesh with worm wheels O 354, O 352, O 350, O 348, O 346, O 344, O 342, and O 340 and helical gear O 338 mounted on the rear lead screws of the tuning racks. The racks corresponding to rf bands A through G are operated by reversible lead screws, with the different rates of travel for the tuning racks determined by the gear ratios involved, as indicated in figure 45. A clamp at the hub of each worm wheel or helical gear (O 337 or O 338) may be loosened so that the lead screw may be turned to aid in synchronization of the racks. The racks for the buffer plate circuit and the first-mixer injection circuits are operated by standard, 10-32 thread lead screws. As indicated in figure 45, lead screws for the rack for the buffer plate circuit are left-hand threaded, and those of the first-mixer injection circuits are right-hand threaded. Rack loading springs (not illustrated) are fastened to the end of each tuning rack to apply tension to the lead-screw drives. In this manner, accurate vertical positioning of the tuning racks is possible. Adjustment screws which are held in the tuning racks are used for alinement of the movable powdered-iron cores associated with the tuned circuits (par. 122).

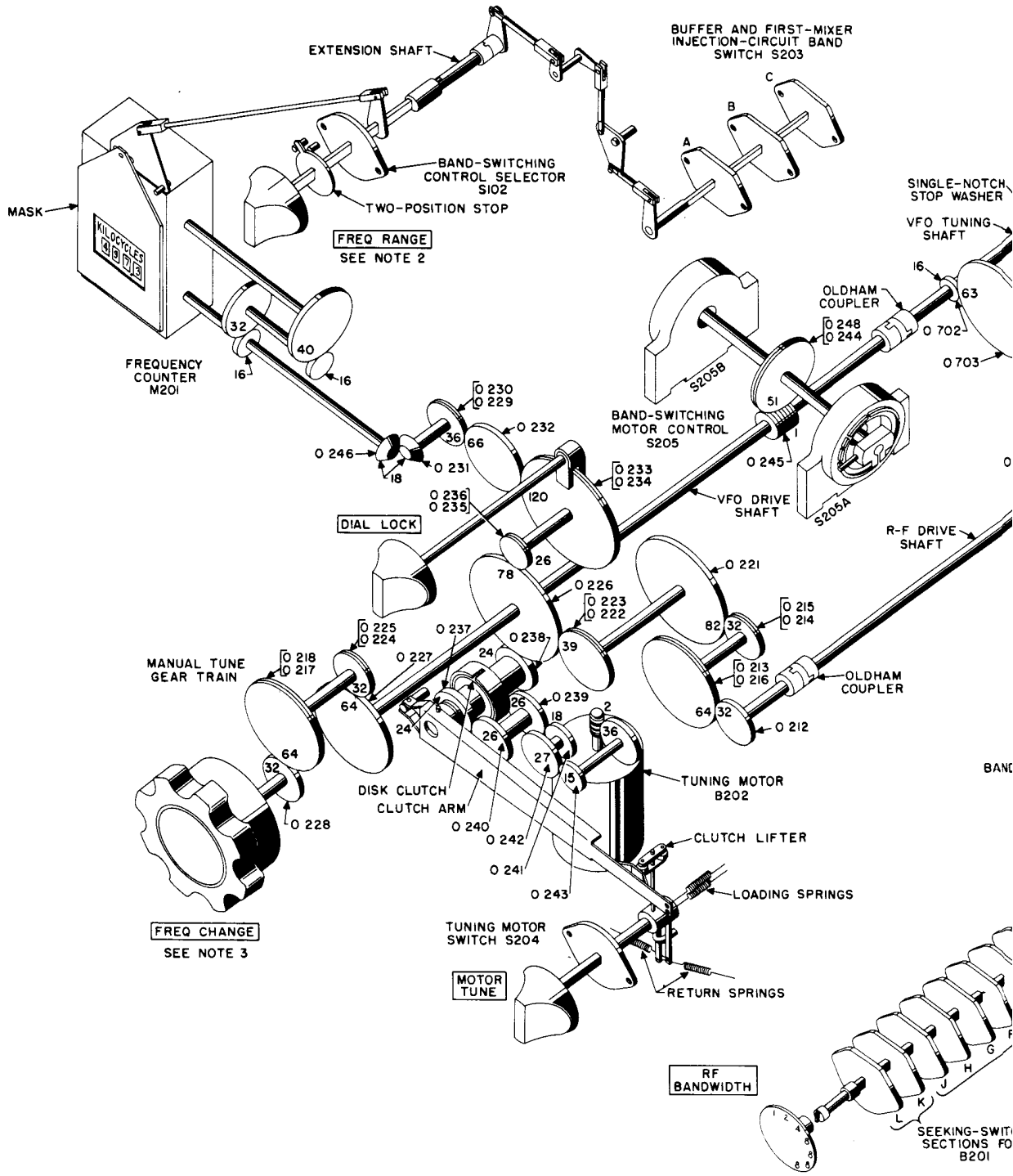

Figure 45. 1

c. Motor Tuning (fig. 45).

- (1) Tuning motor B202 may be energized through operation of MOTOR TUNE switch S204. A potential of 25.2 volts is applied through the contacts of S204 (par. 83c) to operate the motor in either direction.
- (2) Tuning motor B202 drives a worm which, in turn, engages a worm wheel to provide an 18 to 1 stepdown ratio. The vfo drive shaft is driven by spur gear O 226 from the tuning motor worm and worm wheel through a gear train which consists of spur gears O 243, O 242, O 241, O 239, O 240, and O 237, the disk clutch, and spur gear O 238. When the disk clutch is not engaged, it slips easily to permit manual tuning without application of appreciable torque to the motor-tune gear train. If mechanical trouble or accidental holding of the manual tuning knob should occur while the clutch is engaged, slippage of the clutch will protect the motor and gear train from damage.
- (3) Mounted on the MOTOR TUNE control shaft are the rotor of wafer switch S204, a clutch lifter, and spring-loaded arms for returning the control to a neutral center position. Each arm has a return spring which causes the arm to bear against a stop pin. A lever attached to the shaft is located between each of the arms, and the action of the return springs tends to center the rotation of the control shaft at its neutral position. As the MOTOR TUNE control is operated in either direction, the lever carries one of the arms away from its associated stop pin. If the MOTOR TUNE control knob is not held in this position, the control shaft is automatically returned to its neutral (off) position.
- (4) The disk clutch consists of two sets of clutch disks mounted between two concentric gears. Input gear O 237 is driven from the motor gear train, and output gear O 238 drives spur gear O 226 on the vfo drive shaft. The input gear is fastened to a slotted hub which engages the tangs of a set of clutch disks mounted over the hub. A second set of clutch disks is equipped with outward tangs which en-

gage a slotted outer housing, which, in turn, is fastened to the output gear. Force applied from the spring-loaded clutch arm presses the disks together so that they can transmit sufficient torque from the input gear to the output gear for operation of the tuning system.

- (5) When the MOTOR TUNE control is operated, the clutch lifter on the control shaft is moved to one side, allowing the loading springs attached to the end of the clutch arm to pull inward and act as a lever to apply force to the clutch disks. As the control is returned to its neutral position, the lifter forces the clutch arm outward, releasing the pressure on the disk clutch. The end of the clutch arm nearest to the disk clutch is pinned to an adjustable post which is mounted on the gear frame. Adjustment of the position of this post affects the lever action of the clutch arm in such a manner that positive transmission of torque is achieved when the MOTOR TUNE control is operated, and slippage results when the control is at neutral (off).

d. Band Switching.

- (1) The band-switching assembly (fig. 46) consists of band-switching motor B201 and an 11-section wafer switch, S201. Nine wafers of S201 perform rf circuit switching functions: the remaining two wafers of S201 (sections K and L) act as seeking-switch sections for control of band-switching motor B201. At one end of the shaft of S201, and connected to it by an extension shaft, is the RF BANDWIDTH dial. This dial is viewed through a small hole in the front panel of the receiver to indicate the maximum bandwidth passed by the tuned rf circuits in use.
- (2) When the FREQ RANGE control is set to the 15-500 KC position, five different sets of coils are required; when the control is set to the 500-1500 KC position, two sets of coils are required. For the purposes of this discussion, and as referenced in figure 46, the five bands of frequencies covered in the 15- to 500-kc range are designated as bands A through E; the two remaining bands are desig-

nated as F and G. For clarity, plugs and receptacles in the interconnecting leads between S201 and S205 of figure 46 have been omitted. Refer to figure 89 for information relative to plugs and receptacles involved in this circuit. The required set of rf coils is selected by band switch S201. As the **FREQ CHANGE** control is rotated from one frequency to a new frequency which requires a different set of rf coils, band-switching motor B201 operates band switch S201. The operation of B201 is controlled by band-switching motor control S205 (fig. 46). Switch S205 is driven by the **FREQ CHANGE** control from the vfo drive shaft, and when a different set of rf coils is required, S205 acts to remove the bias from relay control V210 by grounding the cathode (pin 7) of V210 through seeking-switch section S201K. The operation of relay control V210 and the band-switching motor power supply is described in paragraphs 84 and 83*d*, respectively; however, it is sufficient at this time to state that removal of bias (grounding of pin 7 of V210) will cause motor control relay K201 to energize, and thus, band-switching motor B201 will operate to rotate band switch S201. Sections A through J of S201 are connected to the various rf coils. When band switch S201 has rotated to select the proper set of rf coils, switch section K opens the circuit through S205, removing the ground, to restore bias at the cathode of relay control V210. Motor control relay K201 is then de-energized, dynamic braking is applied to B201 through action of R289 connected across the armature of V201 by contacts 8 and 9 of K201, and band switch S201 is instantly stopped at the open-contact position of S201K. During the period of time that motor control relay K201 is energized, contacts 5 and 6 of K201 silence the receiver audio output by placing a ground at the input of the local and line audio amplifiers. This reduces the receiver noise output which would otherwise be present during the band-switching operation.

- (3) Band-switching motor control S205 consists of two sections; one section (S205A) for the 15- to 500-kc range, and a second section (S205B) for the 500- to 1,500-kc range. The rotor contact of S205 for the selected range is connected to the cathode (pin 7) of relay control V210 through contacts of **FREQ RANGE** switch S102. The rotors are driven from the vfo drive shaft and turn a few degrees less than 360° while the **FREQ CHANGE** control operates throughout its complete range. The rotor of each section of S205 contains two wipers for completing the relay control circuit. The long wiper for each section contacts segments that are connected to corresponding contacts of seeking-switch section S201K. The segments and the narrow gaps that separate the segments cover 360° on each section. The length of the segment arc for any band is determined by the frequency span for that particular band. As the **FREQ CHANGE** control is rotated and a band change is required, the cathode circuit of relay control V210 is grounded through the segments of S205 and section K of band switch S201. The cathode remains grounded until B201 has rotated the band switch to the position required for the new band. At this time, the notch in the rotor of seeking-switch section S201K breaks the circuit which is connected to the cathode of V210 through S205, and cutoff bias returns to V210. Motor control relay K201 de-energizes to disable band-switching motor B201.
- (4) When **FREQ RANGE** switch S102 is operated from one position to the other, the relay control circuit must be grounded immediately to select a different set of rf coils. Occasionally, when S201 selects a section of S205, the long wiper of the newly selected section lies in a gap between two segments. The cathode of relay control V210 cannot be grounded through the long wiper in the usual manner; it is, therefore, grounded through the short wiper and short contact which is located 180° opposite the gap engaged by the long wiper. The circuit remains grounded through

seeking-switch section S201L until the long wiper on the rotor of S205 has been rotated sufficiently to complete the circuit through another segment and seeking-switch section S201K. Since the angle of rotation for the rotors of S205 is not quite 360° , and the long wiper never engages the gap which is between segments E and A, nor the gap between segments G and F, short contacts are not required for these gaps. The notch in the rotor section of seeking-switch section S201L

is wide enough to allow an open circuit at two adjacent switch contacts. This arrangement prevents grounding of the relay control circuit through the short contacts when tuning from one band to the next within either range of the receiver. Therefore, the short contacts operate the relay control circuit only when a different range is selected by the **FREQ RANGE** control, and the long wiper that is selected by the contacts of S102 lies in a gap between segments of S205.

CHAPTER 6

FIELD MAINTENANCE

This chapter contains information for field maintenance. The amount of repair that can be performed by units having field maintenance responsibility is limited only by the tools and test equipment available and by the skill of the repairman.

Section I. TROUBLESHOOTING AT FIELD MAINTENANCE LEVEL

Warning: When servicing the receiver, avoid contact with the power supply and plate circuits. The high voltages present in these circuits can cause serious injury.

90. Troubleshooting Procedure

a. General. The first step in servicing a defective Radio Receiver R-389/URR is to sectionalize the fault. Sectionalization means tracing the fault to the subchassis responsible for the abnormal operation of the receiver, or to the front panel and main frame. The second step is to localize the fault. Localization means tracing the fault to the bad *circuit* on the subchassis or front panel and main frame. Finally, by voltage, resistance, and continuity measurements, the defective *part* is isolated. Some faults, such as burned-out resistors, shorted transformers, and loose connections often can be located by sight, smell, and hearing. The majority of faults, however, must be located by *checking voltage and resistance*.

b. Detailed Procedure. The tests listed below are to be used as a guide in isolating the source of the trouble. To be effective, *the procedure should be followed in the order given*. Remember that the servicing procedure should cause no further damage to the receiver. Subparagraphs (1) through (6) below contain references to paragraphs having detailed information for carrying out the tests.

- (1) *Visual inspection.* It is often possible to locate troubles within an equipment by inspecting the condition of the wiring and detail parts for visible evidence of failure. This inspection (par. 96) can be quickly and simply carried out, and is capable of yielding rapid results. There

may be no need for involved tests. It is the first to be applied in the troubleshooting procedure.

- (2) *Checking B+ and filament circuits for shorts.* These measurements (par. 97) prevent further damage to the receiver from possible short circuits. This test also gives an indication of the condition of the filter circuit.
- (3) *Operational test.* After it has been determined in the preceding test ((2) above) that a short is not present in the receiver, an operational test (par. 98) is carried out. By using the information gained from observing the symptoms of faulty operation, it is often possible to determine the exact nature of the fault.
- (4) *Troubleshooting chart.* The troubleshooting chart (par. 99) presents a systematic method for checking out the receiver by eliminating possible sources of trouble until the actual trouble is found.
- (5) *Signal substitution.* Signal substitution (pars. 101 through 107), when used with the troubleshooting chart, provides an effective method for methodically tracking down trouble in a receiver.
- (6) *Intermittents.* In all these tests the possibility of intermittents should not be overlooked. If present, this type of trouble may be made to appear by tapping or jarring the subchassis or parts under test. It is possible that the trouble is not in the receiver itself, but in the installation (mounting, antenna, ground, auxiliary equipment, or vehicle), or the

trouble may be due to external conditions. In this event, test the installation.

91. Troubleshooting Data

Take advantage of the information supplied in this manual. It will help in the rapid location of faults. Consult the following troubleshooting data:

Fig.	Par.	Description
	83c	Filament, oven heater, and tuning-motor circuits.
	86	Control circuits.
	87, 88, 89	Mechanical tuning system.
	108	Dc resistances of transformers and coils.
5 and 6		Tube locations.
47 and 48		Fabrication of bench-test cables.
49 through 61		Top and bottom views of subchassis, showing locations of parts.
62 and 63		Power Supply PP-621/URR, top and bottom views.
64 and 65		Main frame, top and bottom views.
66 and 67		Tube-socket voltage and resistance diagrams.
68		Terminal-board voltages and resistances.
84		Resistor color code marking.
85		Capacitor color code marking.
88		Subchassis and interconnection diagram.
89		Schematic diagram.
90		Wiring diagram.

92. Test Equipment and Tools Required for Troubleshooting

a. The test equipment required for troubleshooting Radio Receiver R-389/URR is listed below. The technical manuals associated with the test equipment, where applicable, are also listed.

Test equipment	Technical manual
Electron Tube Test Set TV-2/U, or equal.	TM 11-2661
Signal Generator TS-588A/U, or equal.	TM 11-5018
Audio Oscillator TS-382A/U, or equal.	TM 11-2684A
Electronic Multimeter TS-505/U, or equal.	TM 11-5511
Multimeter TS-352/U, or equal.	TM 11-5527

b. The tools and materials contained in Tool Equipment TE-113 are required for field maintenance of Radio Receiver R-389/URR.

93. Bench Testing Technique

a. When the cause of equipment failure has been sectionalized to a subchassis, as determined by visual inspection, operational test, or the use of the troubleshooting chart, a bench test of the faulty subchassis may be required to locate the trouble through voltage readings. Since the undersides of the subchassis are not accessible for troubleshooting when the subchassis are mounted in the receiver, it may be necessary to remove the subchassis under test and connect them to the receiver circuits by the use of extension cables. Directions for the fabrication of the extension cables are given in figures 47 and 48. The amount and types of extension cables needed can be determined from the table in b below.

b. To prepare a subchassis for bench testing, remove the subchassis from the receiver according to the instructions contained in paragraph 110. *Be careful to avoid the possibility of disturbing the synchronization of the gear train with the rf subchassis and vfo subchassis.* Connect the extension cables between the receiver and subchassis according to the table below.





Caution: When the subchassis are operated outside the receiver, dangerous voltages are exposed at the tube-socket pins and other points on the undersides of the chassis.

Subchassis	Cable No.	Connect between
Rf	1A	P209-J109
	1A	P210-J110
	1A	P211-J111
	1A	P230-P730
	1	J223-J525
	1	J224-J526
	2	J227-P127
Rf subassembly	3	J228-P128
	4	J229-P129
Af	4	J221-P221
	4	J222-P222
Ac power supply	5	J619-P119
	3	J620-P120
Vfo	6	J818-P118
	1A	P730-J230
If	7	P731-J131
	1A	J512-P112
	1	J525-P223
	1	J526-P224
	2	J517-P117

Note. When cable No. 1A is used, Z217 and Z218 (buffer plate) circuits will be detuned.

NOTE:

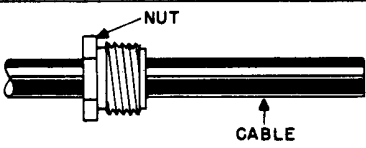
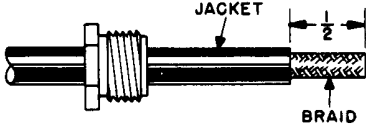
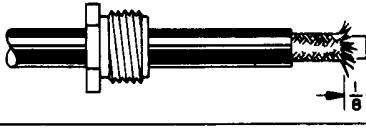
INSTRUCTIONS ARE GIVEN BELOW, IN STEP-BY-STEP SEQUENCE, FOR ATTACHING RADIO FREQUENCY PLUG UG-88/U TO EACH END OF THE CABLE NO.1. CABLE NO.1A IS ASSEMBLED IN THE SAME MANNER EXCEPT THAT FEMALE CONTACT AND JACK BODY OF RADIO FREQUENCY JACK UG-89/U ARE SUBSTITUTED AT ONE END OF CABLE.

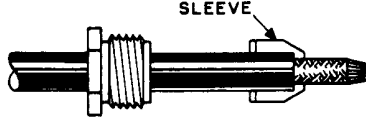
ASSEMBLING RADIO FREQUENCY PLUG UG-88/U		 NUT	 SLEEVE
STEP 1			CU
STEP 2			RE N/A
STEP 3			PU 1/8
STEP 4			TA
STEP 5			SL FIT SQ

RADIO FREQUENCY PLUG UG-88/U

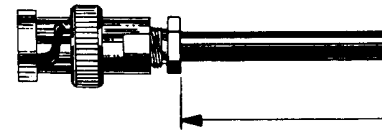

NOTE:

IN STEP-BY-STEP SEQUENCE, FOR ATTACHING TO EACH END OF THE CABLE NO.1. CABLE NO.1A IS THE SAME EXCEPT THAT FEMALE CONTACT AND JACK UG-89/U ARE SUBSTITUTED AT ONE END OF



NUT



SLEEVE



MALE CONTACT

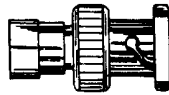

PLUG BODY

	CUT END OF CABLE EVEN.	STEP 6	
	REMOVE OUTER JACKET 1/2"—DON'T NICK BRAID.	STEP 7	
	PUSH BRAID BACK, AND REMOVE 1/8" OF INSULATION AND CONDUCTOR.	STEP 8	
	TAPER BRAID.	STEP 9	
	SLIDE SLEEVE OVER TAPERED BRAID. FIT INNER SHOULDER OF SLEEVE SQUARELY AGAINST END OF JACKET.	STEP 10	

Figure 47. Assembly instruction for cables Nos. 1 and 1A.

CABLE NO.1
RADIO FREQUENCY CABLE RG-58 C/U

RADIO FREQUENCY PLUG UG-88/U

RADIO FREQUENCY PLUG UG-88/U

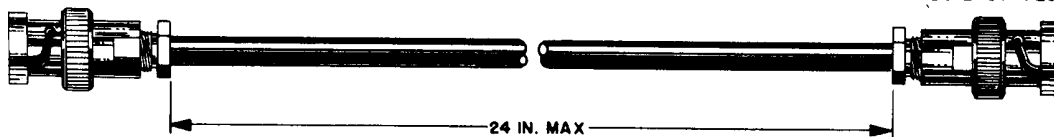

COMPLETED CABLE

	<p>WITH SLEEVE IN PLACE, COMB OUT BRAID, FOLD BACK SMOOTH AS SHOWN, AND TRIM $3/32$".</p>
	<p>BARE CENTER CONDUCTOR $1/8$" — DON'T NICK CONDUCTOR.</p>
	<p>TIN CENTER CONDUCTOR OF CABLE. SLIP MALE CONTACT IN PLACE AND SOLDER. REMOVE EXCESS SOLDER. <i>BE SURE CABLE DIELECTRIC IS NOT HEATED EXCESSIVELY AND SO SWOLLEN AS TO PREVENT DIELECTRIC ENTERING BODY.</i></p>
	<p>PUSH INTO BODY AS FAR AS IT WILL GO. SLIDE NUT INTO BODY AND SCREW INTO PLACE, WITH WRENCH, UNTIL MODERATELY TIGHT. HOLD CABLE AND SHELL RIGIDLY AND ROTATE NUT.</p>
	<p>ASSEMBLED CONNECTOR.</p>

cables Nos. 1 and 1A.

NOTES:

1. THE MULTICONDUCTOR EXTENSION CABLES ARE TO BE FABRICATED FROM NO. 18 TO 22 GAUGE SHIELDED, STRANDED WIRE FOR AUDIO CONDUCTORS INDICATED BY ○, NO. 18 GAUGE STRANDED WIRE FOR CONDUCTORS INDICATED BY ●, NO. 22 GAUGE STRANDED WIRE FOR ALL OTHER CONDUCTORS. INSULATED AND RATED AT 600V.
2. CONNECTORS SHOWN VIEWED FROM REAR. COVERS TO BE USED ON ALL CONNECTORS. SIGNAL CORPS STOCK NUMBERS ARE SHOWN FOR EACH CONNECTOR.
3. CABLES TO BE LACED WITH NO. 6 VINYLITE LACING CORD INSERT.
4. MAXIMUM LENGTH OF ALL CABLES IS 24 IN.
5. CHECK CONTINUITY AFTER COMPLETING FABRICATION.
6. LABEL EXTENSION CABLES FOR IDENTIFICATION.
7. NORMALLY, ONE EACH OF EXTENSION CABLES IS REQUIRED FOR EACH SUBCHASSIS IS OPERATED OUTSIDE RECEIVER, THREE NO.1 CABLES ARE NEEDED. WHEN R-F AMPLIFIER/TEST OSCILLATOR SUBASSEMBLY IS OPERATED OUTSIDE RECEIVER, TWO NO.4 CABLES ARE NEEDED.

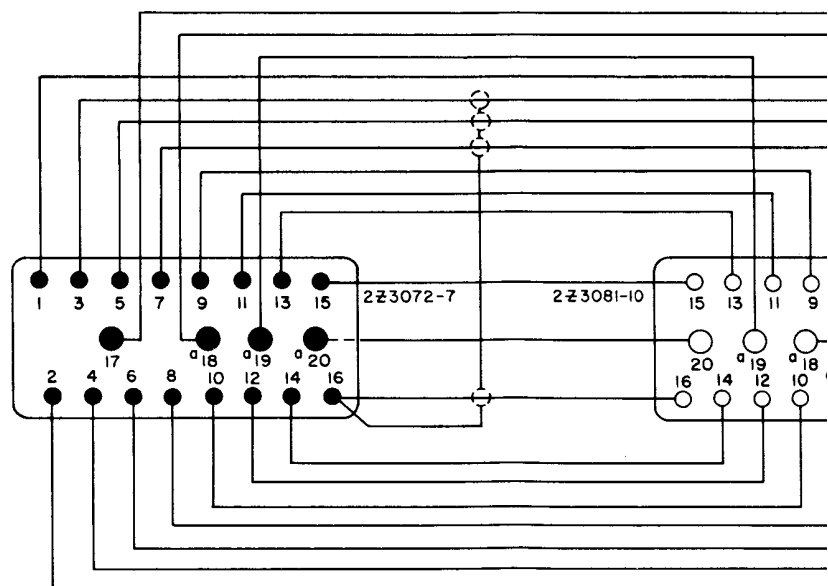
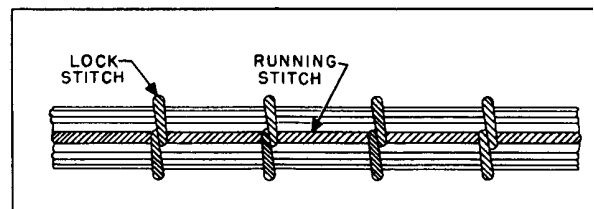

CABLE NO. 2

NOTES:

EXTENSION CABLES ARE TO BE FABRICATED OF STRANDED WIRE FOR AUDIO CONDUCTORS AND STRANDED WIRE FOR CONDUCTORS MARKED ^a, AND FOR ALL OTHER CONDUCTORS, INSULATION MUST BE

REMOVED FROM REAR. COVERS TO BE USED WITH NUMBERS ARE SHOWN FOR EACH CONNECTOR.

USE WITH NO. 6 VINYLITE LACING CORD AS SHOWN IN

LENGTH OF ALL CABLES IS 24 IN.

IMMEDIATELY AFTER COMPLETING FABRICATION.

MARK CABLES FOR IDENTIFICATION.

IF EXTENSION CABLES IS REQUIRED. IF R-F RECEIVER, THREE NO.1 CABLES ARE NEEDED. IF MOST OSCILLATOR SUBASSEMBLY IS OPERATED, TWO NO.1 CABLES ARE NEEDED.

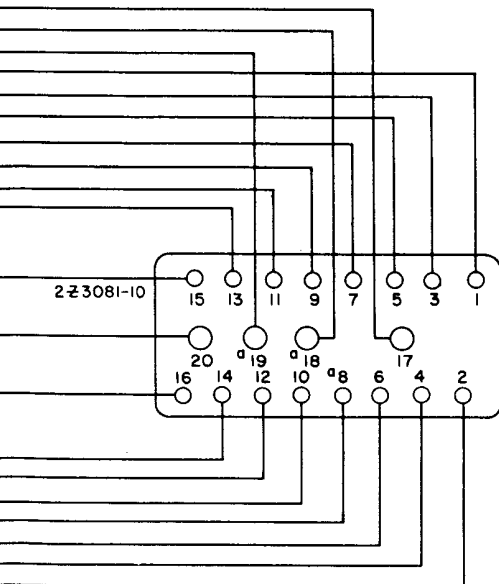
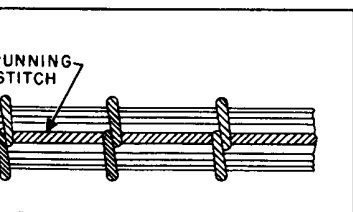

CABLE NO. 2

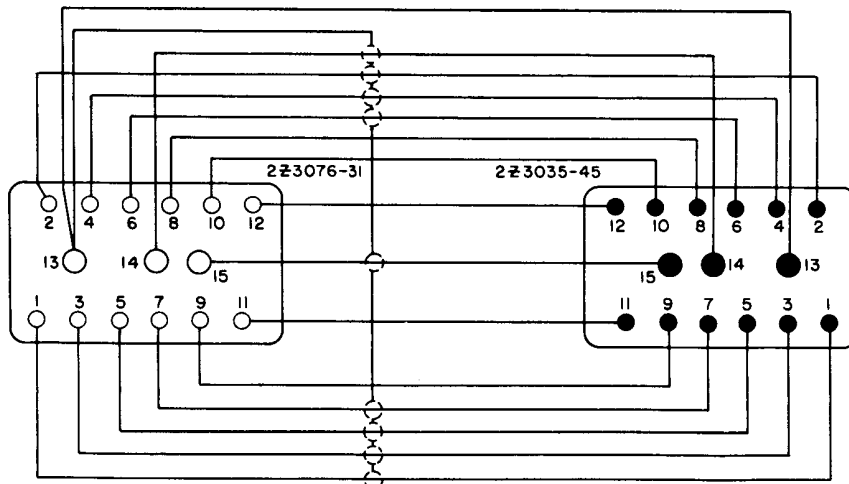

CABLE NO. 5

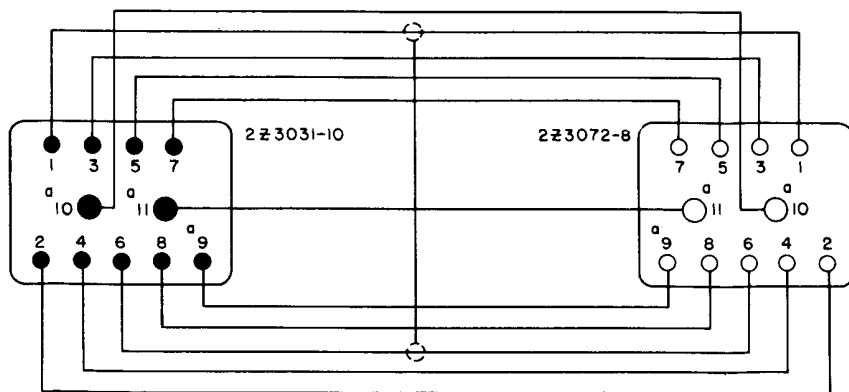

CABLE NO. 3

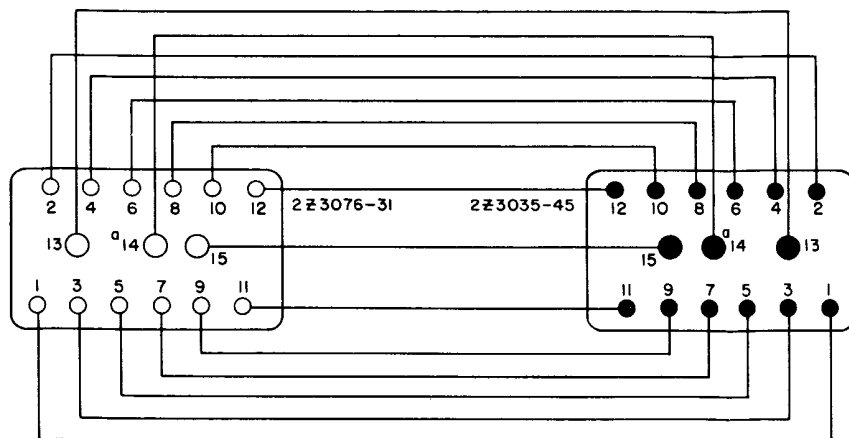

CABLE NO. 6

Figure 48. Assembly instructions for multiconductor cables.

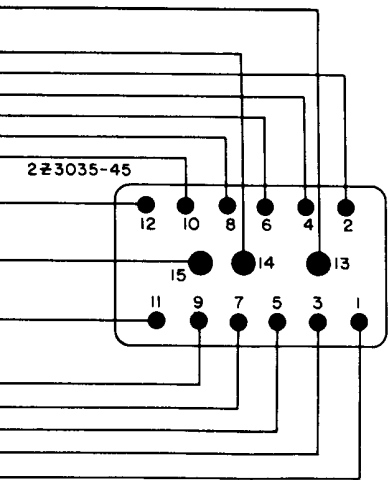

0.5

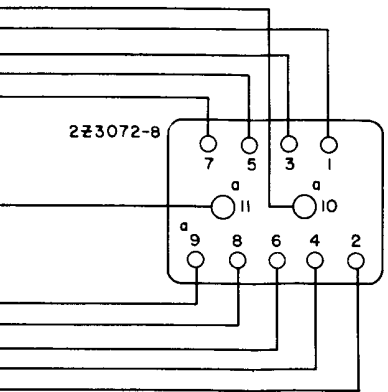

0.3

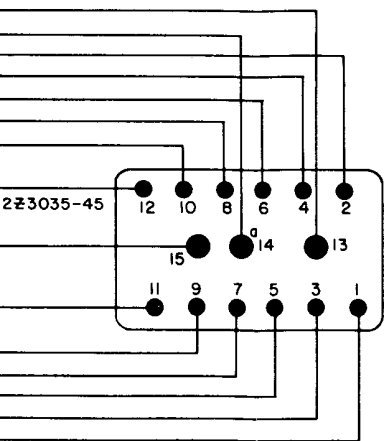

E NO.6

for multiconductor cables.

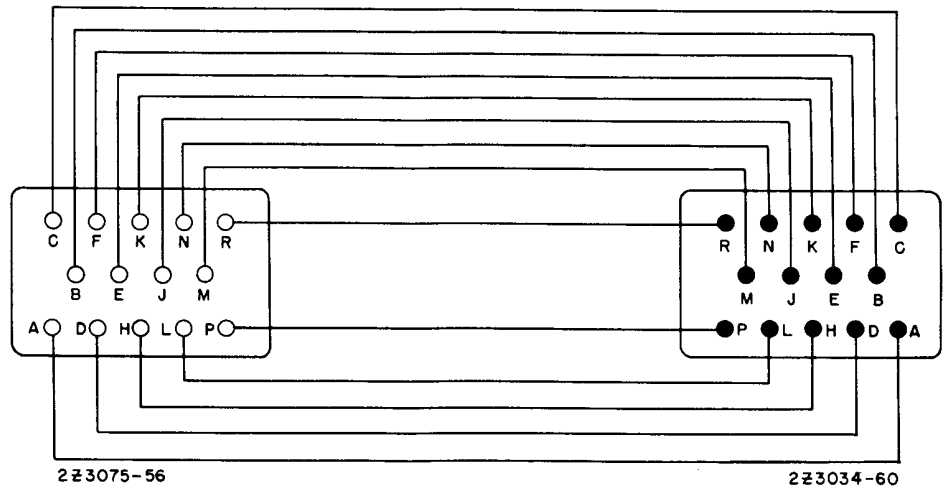

CABLE NO.4

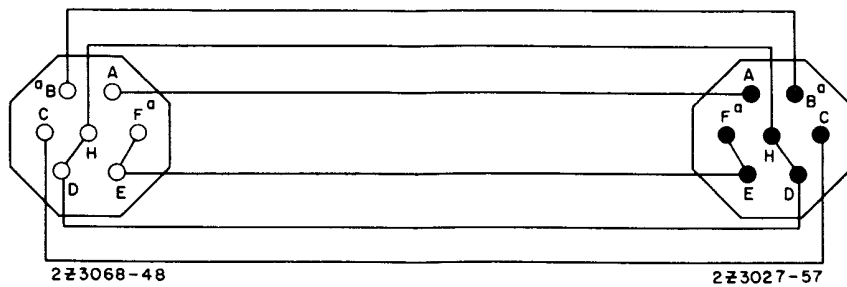

CABLE NO.7

94. General Precautions

When a receiver is to be serviced, observe the following precautions very carefully:

a. When the receiver is removed from the case, cabinet, or rack for servicing, ground the main frame and any subchassis operated outside the main frame before connecting the power cord.

b. Be sure that the receiver is disconnected from the power source or is turned off before contacting high-voltage circuits or changing connections.

c. After disconnecting auxiliary equipment and before testing the receiver, connect pairs of terminals on the back-panel terminal strips as shown in figure 7.

d. After disconnecting the tuning shafts for removal of a subchassis, avoid turning the shafts or tuning controls unless necessary for troubleshooting or adjustment. Careful handling may eliminate the need for synchronization. It will be helpful to make a note of the positions of the front-panel controls indicated in the removal procedure upon removal of a subchassis, because a control may be inadvertently disturbed during servicing.

e. Do not operate the receiver for excessive periods of time with the vfo subchassis disconnected and the FUNCTION switch in the STAND BY position. The regulated dc voltage rises to a value of approximately 275 volts when the vfo subchassis is disconnected and damage to the power supply may result. Do not rotate FREQ CHANGE knob while the vfo subchassis is removed from the receiver. The 52-turn stop is not operative, and serious damage to the tuning racks may result if the control travels to either extreme.

f. Careless replacement of parts often causes new faults. Note the following points:

- (1) Before unsoldering a part, note the position of the leads. If the part has a number of connections, tag each of its leads.
- (2) Be careful not to damage other leads while pulling or pushing them out of the way.
- (3) Do not allow drops of solder to fall into the receiver. They may cause short circuits.
- (4) A carelessly-soldered connection may create a new fault. It is very important to make well-soldered joints. A poorly-soldered joint is one of the most difficult faults to find.

- (5) *When a part is replaced in the rf or if. circuits, it must be placed in the exact position of the original part. A part that has the same electrical value but different physical size may cause trouble in high-frequency circuits. Give particular attention to proper grounding when replacing a part. Use the same ground as in the original wiring. Failure to observe these precautions may result in decreased gain or, possibly, in oscillation of the circuit.*

g. Before taking voltage measurements or performing signal tracing, always check the value of the regulated dc voltage. Approximately 180 volts dc should be obtained at B+ 180 VDC jack J601 located on the af subchassis (figs. 60 and 61). This jack is accessible through the side of the main frame of the receiver (fig. 81).

95. Troubleshooting Notes

a. To avoid the necessity for removing a subchassis when voltage is to be measured or a signal injected at a tube-socket pin that does not have a test point, remove the tube. Wrap a bared end of a short length of insulated wire around the desired tube pin. Be sure that the wire touches only the desired pin; replace the tube. Voltage measurements may now be made at the other bared end.

b. If trouble is suspected in the rf subchassis, perform as much detailed troubleshooting as possible to be sure that the trouble is in the subchassis before removing it because replacement of the rf subchassis is a time-consuming procedure.

c. When the filament of a particular tube fails to light, trouble may be in another tube in the same series filament circuit. Refer to the series filament circuit diagram (fig. 37).

d. When trouble appears to be in regulator tube V605 or V606, first observe that reference tubes V608 and V609 are glowing normally; then check B+ voltage at the B+ 180 VDC jack before testing the regulator tubes with a tube tester.

e. When it is suspected that the frequency of the vfo or bfo is not stable, check the voltage regulator tube (RT512).

96. Visual Inspection

When a receiver is brought in from the field for check or repair, remove the top and bottom dust covers, and inspect it as instructed below.

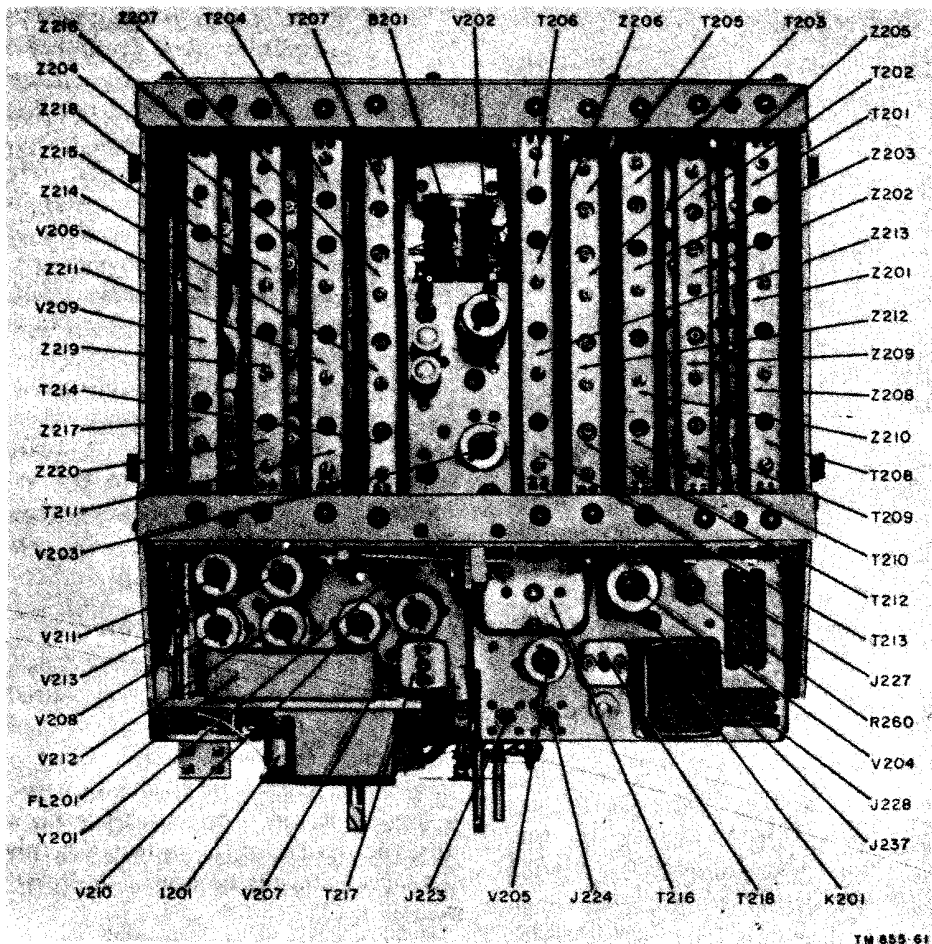

Figure 49. Rf subchassis, top view.

Observe the precautions described in paragraph 94.

a. Inspect all cables, plugs, and receptacles. Check to see that all connectors are seated properly. This is important, because improperly seated connectors are a frequent cause of abnormal operation in equipment. Repair or replace any connectors or cables that are broken or otherwise defective.

b. Inspect for burned insulation and resistors that show signs of overheating. Look for wax leakage and any discoloration of apparatus and wires.

c. Inspect for broken connections to tube sockets, plugs, and other apparatus, as well as for defectively soldered connections. Examine for bare wires touching the chassis or adjoining wires.

d. Be sure that all tubes are in their correct positions, as shown in figures 5 and 6. Replace

any tubes that are not of the type called for in the illustrations. Replace broken tubes. Inspect for loose tube-socket contacts.

e. Inspect the fuses and replace them if necessary, with fuses of correct rating and type. Check carefully for short circuits (par. 97) wherever a blown fuse is found.

f. Operate the tuning mechanism both manually and with the aid of the tuning motor. See that the *FREQ CHANGE* and *FREQ RANGE* controls cause the band-switching motor to operate, and that the controls turn freely. Rough operation or binding indicates a damaged tuning system or need for cleaning and lubrication (par. 111).

g. Check all switches and controls for ease of operation.

h. Check meters for proper operation.

i. Refer to figures 49 through 72 for troubleshooting.

97. Checking B+ and Filament Circuits for Shorts

(fig. 87)

a. To prevent damage to a receiver sent in for repair, always check the resistance of the high-voltage circuits before applying power to the equipment. Repeated burning out of B+3/8A fuse F102 is an indication of a short in one of the high-voltage circuits. Disconnect Power Cable Assembly CX-1358/U from the ac power input, and test the cable assembly (par. 48). After it has been determined that the cable assembly is normal, set the FUNCTION switch at AGC and check the high-voltage circuits as follows:

- (1) The resistance measured between the chassis and tube-socket pin 2 or 5 of each regulator tube, V605 and V606, should be approximately 120,000 ohms. This measurement can be taken at the B+3/A fuseholder by leaving the fuse in place. If the resistance is low, check capacitor C103 (fig. 65) for a short circuit or leakage. If the resistance is abnormally high or infinite, check for an open circuit caused by a break in wiring or a poor connector contact.

- (2) The resistance measured between the chassis and B+ 180 VDC jack J601 should be approximately 19,000 ohms with the FUNCTION switch at OFF or STAND BY, approximately 7,700 ohms with the FUNCTION switch at AGC or MGC, and approximately 6,500 ohms with the FUNCTION switch at SQUELCH. If the resistance is low, check for a short-circuited or leaking bypass capacitor, or for a short in the wiring of one of the plate or screen-grid circuits of the individual subchassis. If the resistance is greater than normal, an open screen-grid resistor is indicated.

- (3) If the tests outlined in (1) and (2) above indicate that a short circuit is present in the receiver, determine in which subchassis it is located, as follows:

- (a) Turn the FUNCTION switch to OFF.
- (b) Disconnect all interconnecting cables that carry power to the subchassis.
- (c) Replace any blown fuses.
- (d) Check to see that the 115V-230V switch on Power Supply PP-621/URR is in the proper position for the available ac power source, and connect

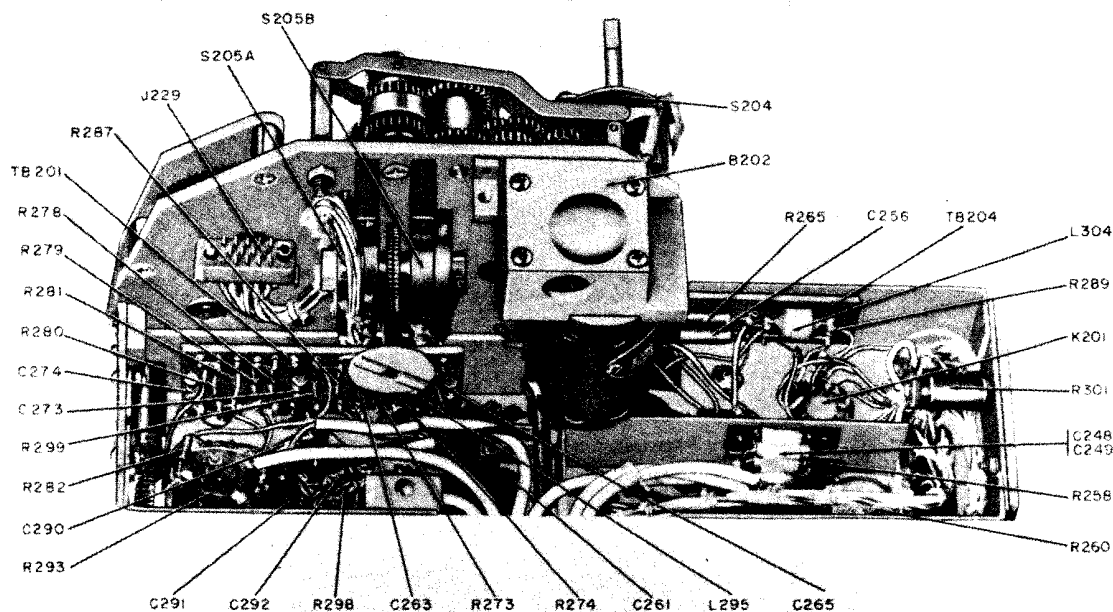

TM855-62

Figure 50. Rf subchassis, bottom view, showing gears.

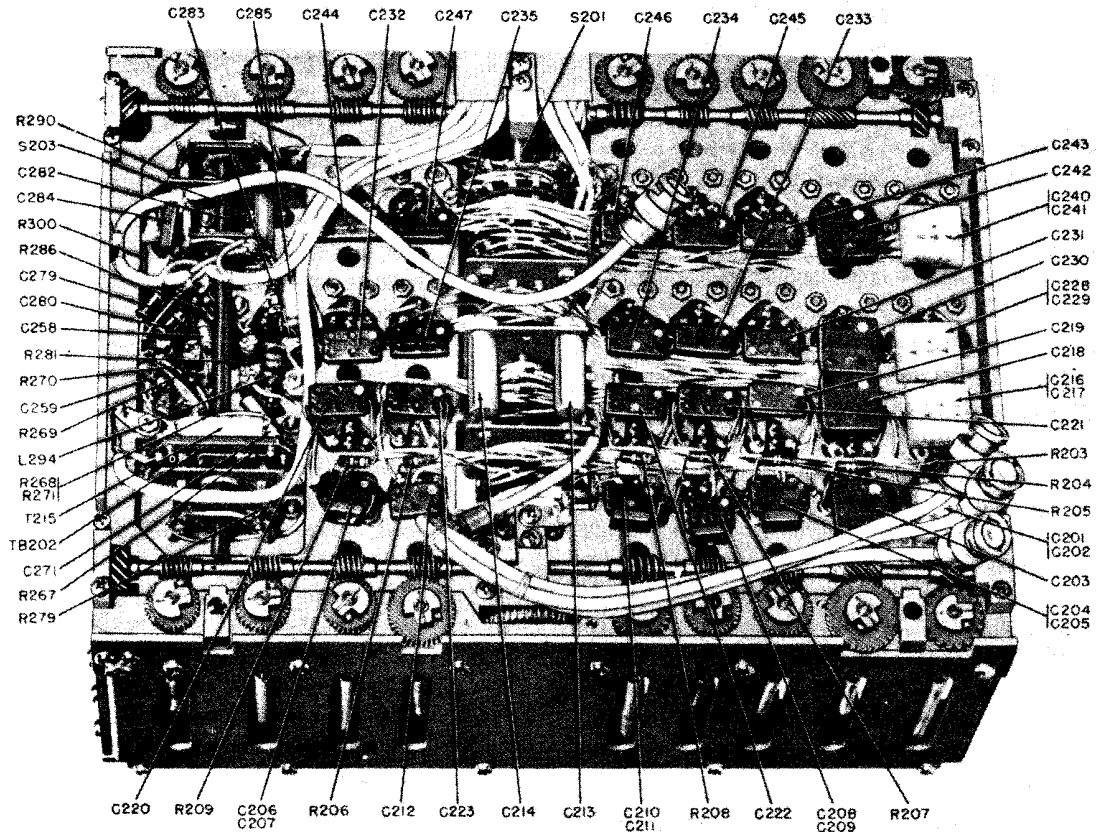

TM855-101

Figure 51. Rf subchassis, bottom view.

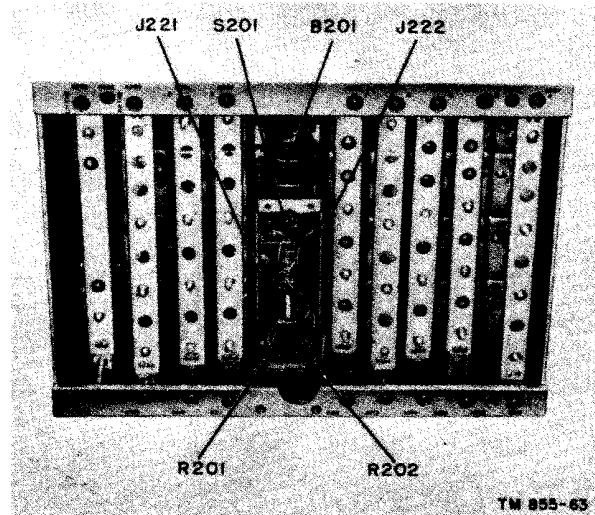

TN 855-63

Figure 52. Section of rf subchassis, showing band-switching mechanism.

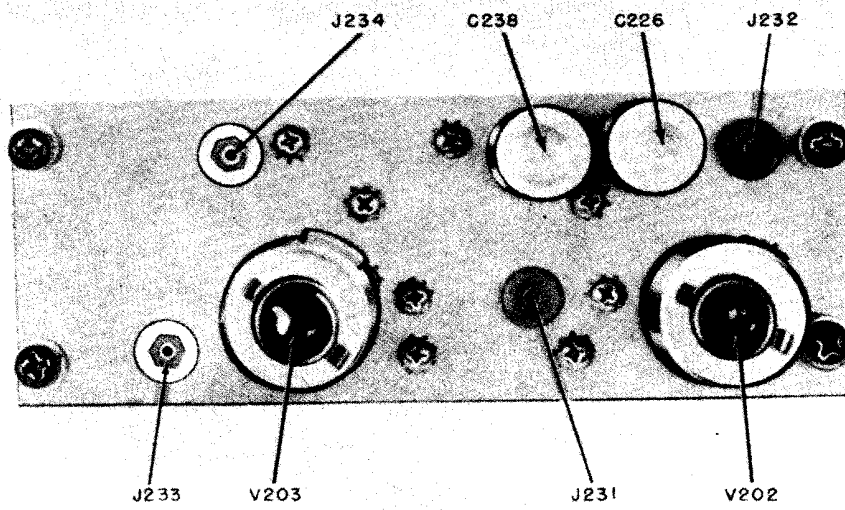

TM 855-64

Figure 53. Rf amplifier subassembly, top view.

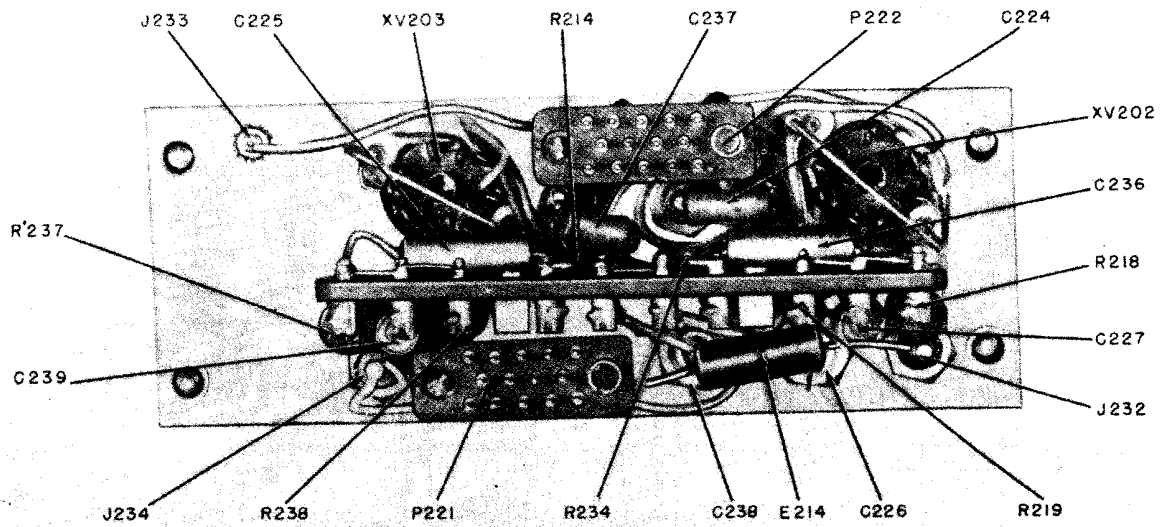

TM 855-65

Figure 54. Rf amplifier, subassembly, bottom view.

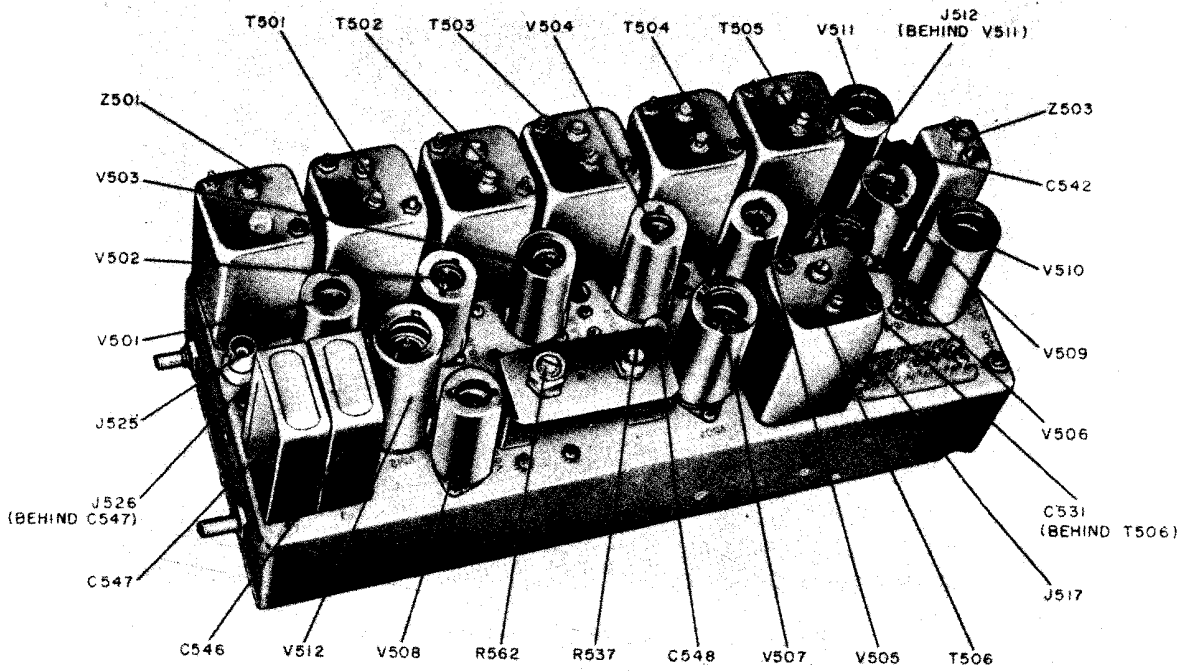

TM 856-66

Figure 55. 1F subchassis, top view.

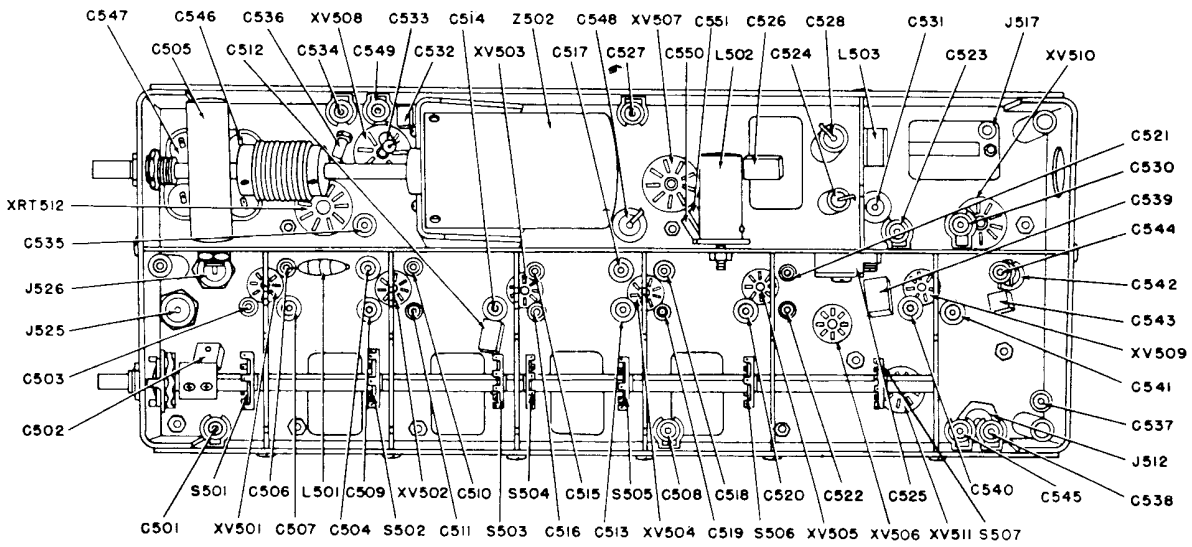

TM 855-67

Figure 56. 1F subchassis, bottom view, showing sockets.

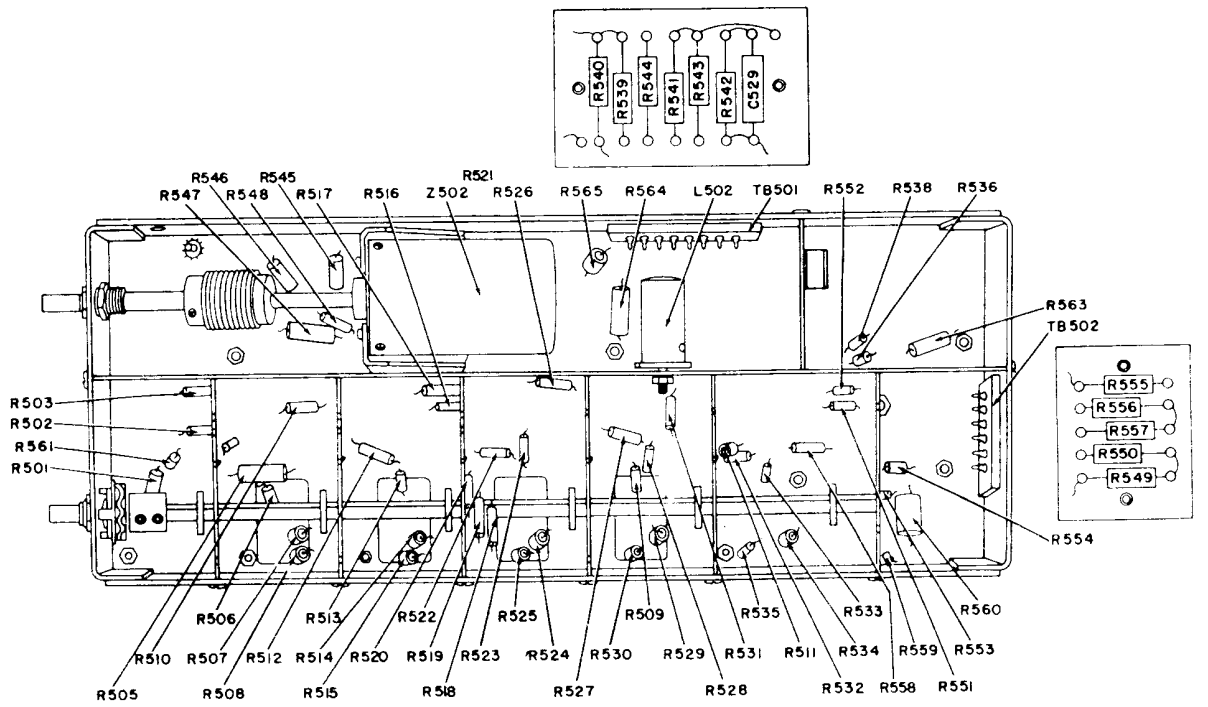

TM 855-68

Figure 57. If subchassis, bottom view.

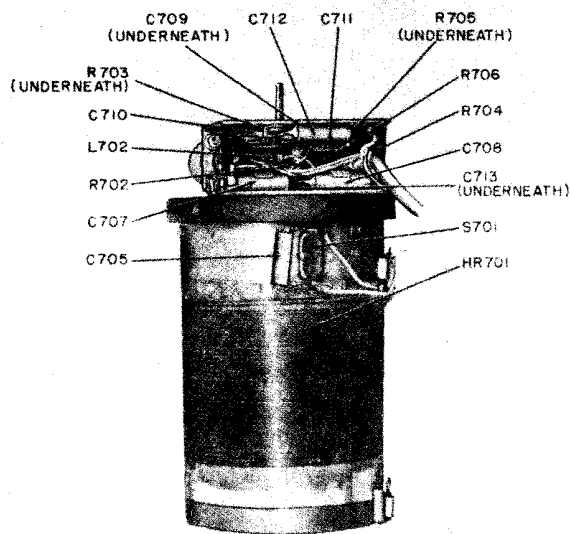

TM 855-69

Figure 58. Vfo subchassis, bottom view, cover removed.

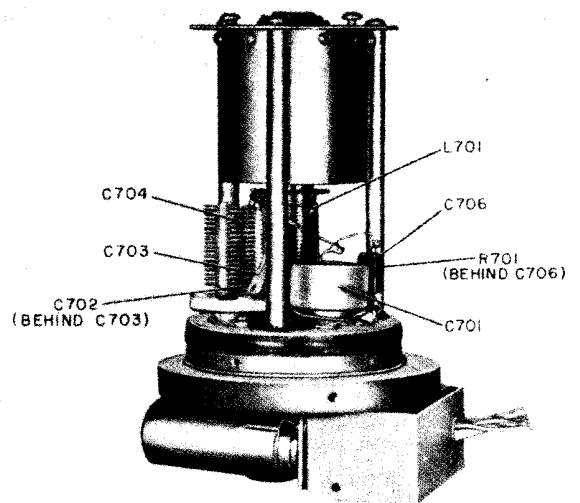

TM 855-70

Figure 59. Vfo subchassis, cover and heating element removed.

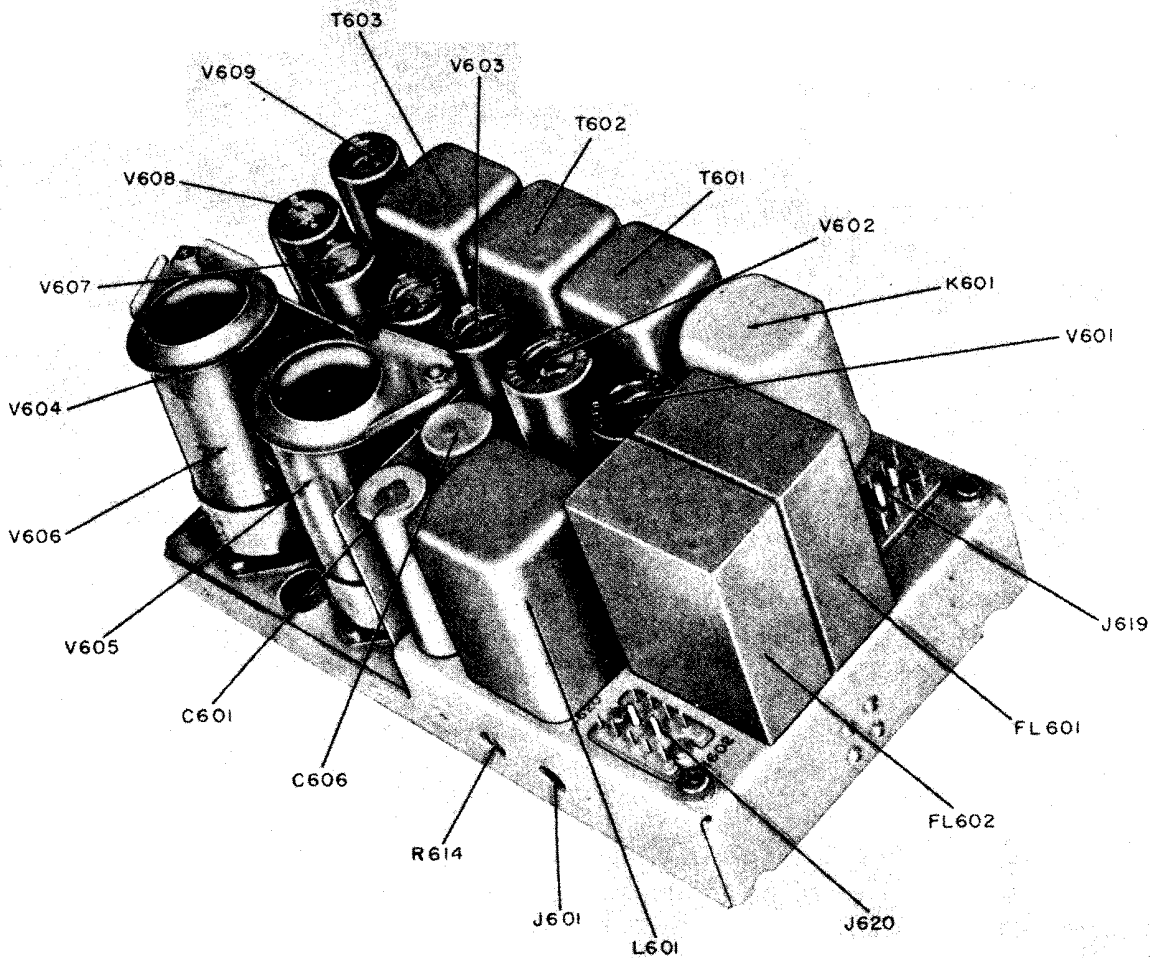

TM 855-71

Figure 60. AF subchassis, top view.

Power Cable Assembly CX-1358 U between the receiver and power source. Turn the FUNCTION switch to AGC.

- (e) Reconnect (one at a time) the cables that carry power to the individual subchassis in the following order: power supply subchassis, af subchassis, if subchassis (turn the BFO switch to ON), vfo subchassis, and rf subchassis. If the B+3/8A fuse blows after the power cable is connected to a subchassis, and, in the case of the if and rf subchassis, the BFO and FUNCTION switches are turned to the positions indicated, there is probably a short circuit in that subchassis or connecting cable.

b. If the tests performed as instructed in a above reveal no trouble, the filament circuits should be checked as follows (fig. 88):

- (1) See that all the necessary interconnecting cables are in position and properly connected.
- (2) Turn the FUNCTION switch to AGC, and check the filament circuits as described in paragraph 43c. A short in the low-voltage or filament circuits will be evidenced by the repeated burning out of AC 3A fuse F101. In addition to a defective filament circuit, a short circuit to ground in oven heater HR701, or dial lamp I 201 or I 202 will seriously affect the low-voltage circuit. If an abnormal filament circuit is indicated, test the tubes

by using one of the techniques described in paragraph 45.

98. Operational Test

a. Operate the equipment as described in the equipment performance check list (par. 47). This check list is important because it frequently aids in sectionalizing the trouble without the need for further testing. Check for overheated parts, faulty controls, and intermittent operation. Observe closely the indications of the CARRIER LEVEL and LINE LEVEL meters. A normal indication on the CARRIER LEVEL meter usually indicates satisfactory operation of the age circuit and all stages up to and including the sixth if. amplifier. If the LINE LEVEL meter

indication is normal, satisfactory operation of the remaining stages, except for the second af amplifier, section A of V602 and the local audio channel output stage, V603, is indicated. These latter stages can be checked by listening to the audio output with a 600-ohm headset or speaker.

b. To check the audio in if. stages quickly, connect a headset to the PHONES jack on the front panel. Turn the FUNCTION switch to AGC. Starting at the 8 KC position of the BANDWIDTH switch, set the switch in turn to each lower position. If the volume of the rushing round heard in the headset decreases noticeably with each lower setting, the if. and audio stages are operating. This test does not necessarily indicate normal operation.

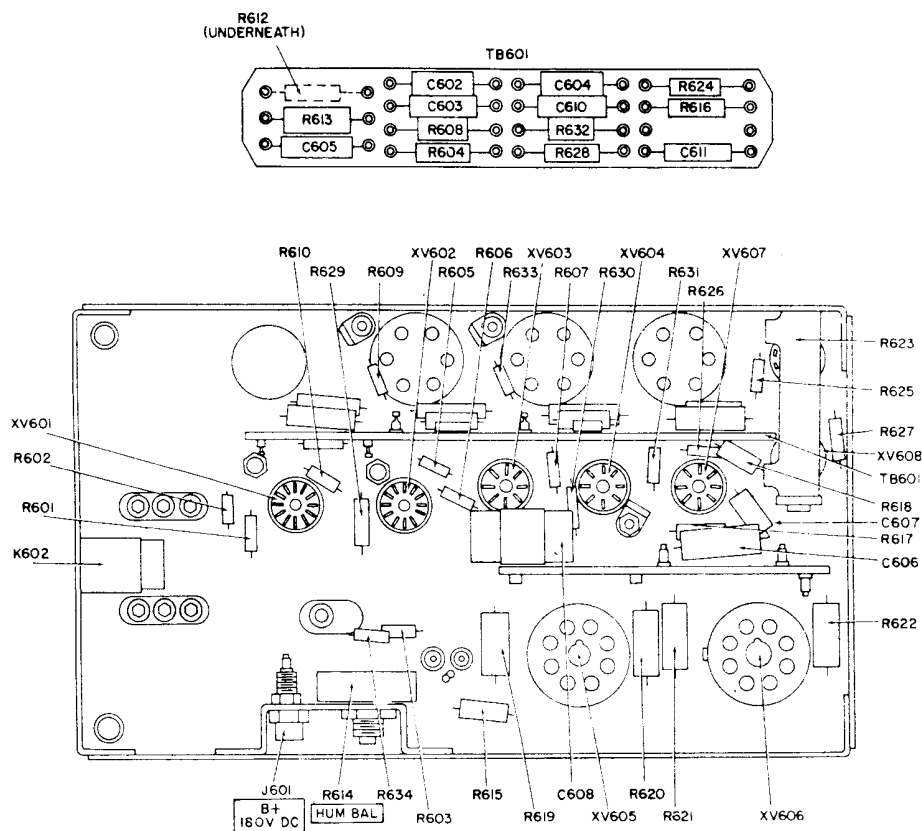

TM 855-72

Figure 61. Af subchassis, bottom view.

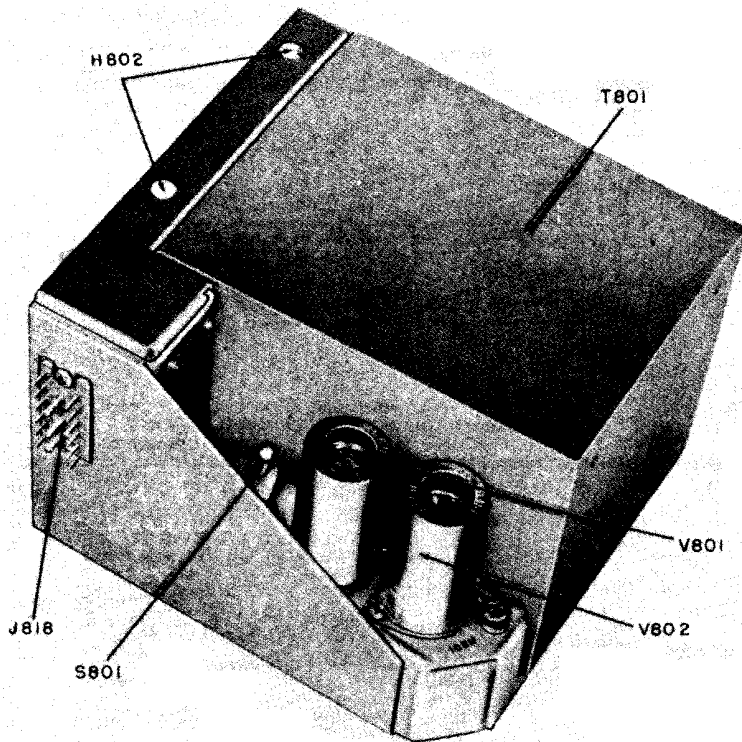

TM 655-73

Figure 62. Power Supply PP-621/URR, top view.

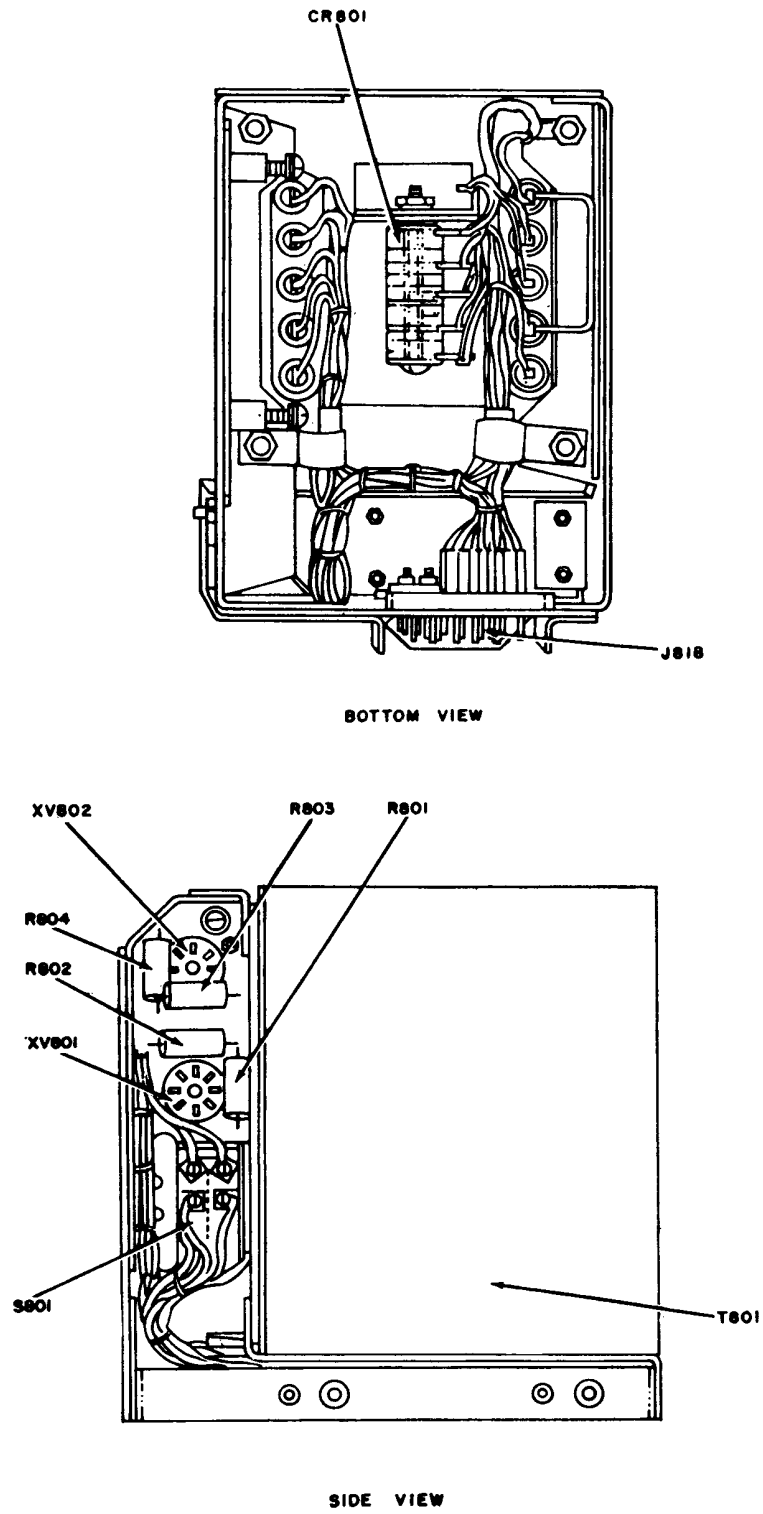

TM855-74

Figure 63. Power Supply PP-621/URR, bottom and side views.

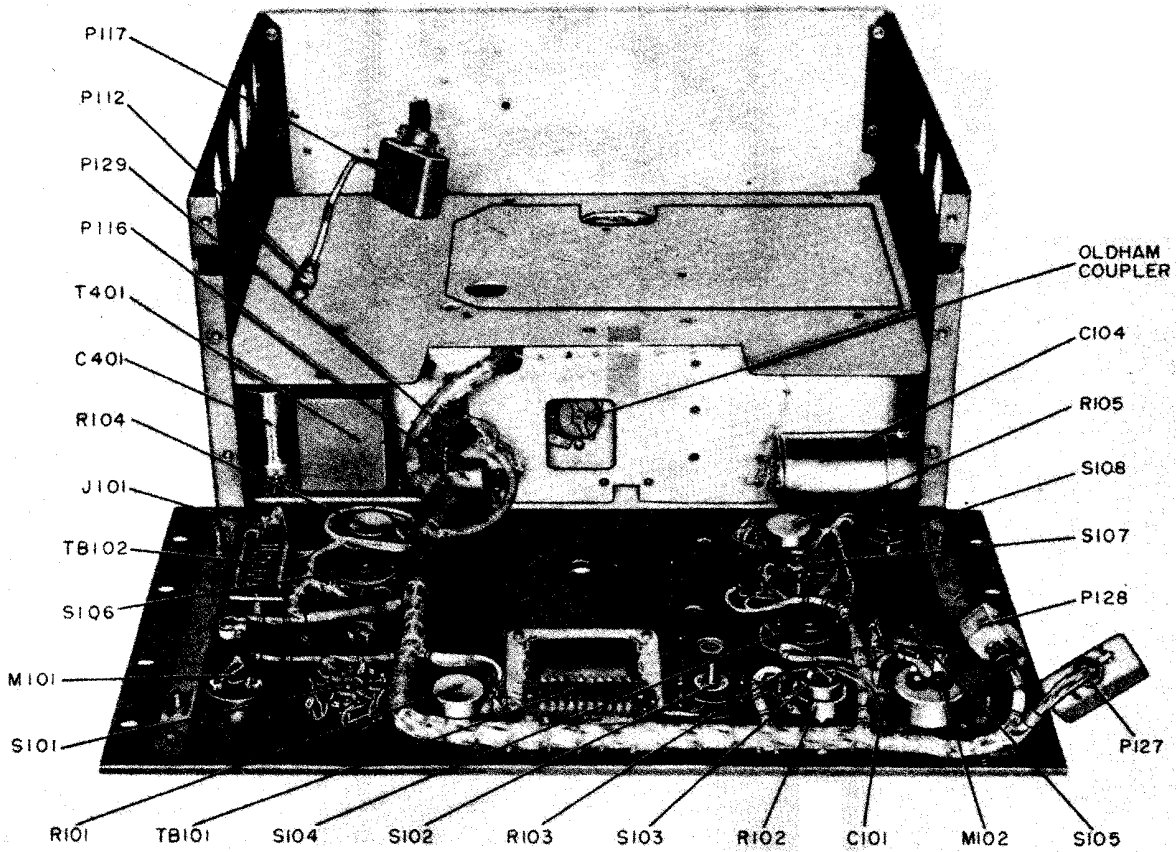

TM 855-75

Figure 64. Front panel and main frame, top view.

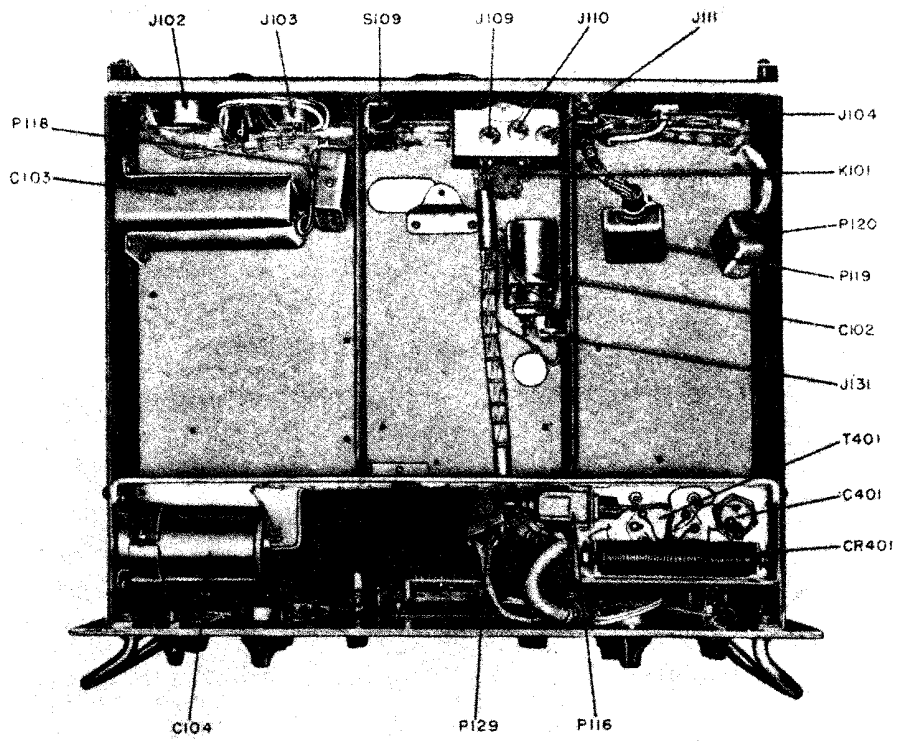

TM 855-76

Figure 65. Front panel and main frame, bottom view.

99. Troubleshooting Chart

The following chart aids in locating trouble in the radio receiver and power supply. This chart lists the symptoms that the repairman sees and hears while making simple tests. The chart also indicates how to localize trouble quickly to the audio, if. or rf. stage that is defective, and also

to defective parts within the tuning system. The signal-substitution tests outlined in paragraphs 101 through 107 can then be used to supplement this procedure and aid in locating the defective stage. Once the trouble has been localized to a stage or circuit, a tube check and voltage and resistance measurements of the stage or circuit should ordinarily isolate the defective part.

Symptom	Probable trouble	Correction
1. When FUNCTION switch is in AGC position, receiver fails to operate and dial lamp does not light.	Open AC 3A fuse (F101) on rear panel of receiver.	Replace fuse. If it blows again, check power supply, filament, and oven circuits for shorts. Check primary power connections.
2. Dial lamp lights, but CARRIER LEVEL meter shows no indication. No reception.	No B+ voltage. Open B+ 3/4A fuse (F102) on rear panel of receiver.	Replace fuse. If it blows again, test capacitor C103 for short. Test plate and screen-grid circuits for shorts (par. 97).
3. No receiver output. Indication on CARRIER LEVEL meter rises and dips as KILOCYCLE CHANGE control is rotated.	Fault is in signal circuit after 6th if. stage.	Connect headset in series with a .1- μ f capacitor across grid circuit and plate circuits of successive audio stages to localize defective stage. Stage may also be localized by signal substitution (par. 101). Test tube of defective stage (note series filament circuits (par. 82c)). If necessary, check voltages and then resistances of circuits within a stage (figs. 66, 67, and 68) to locate a defective part.
4. Af circuits function satisfactorily, but no signal output is obtained when 455-kc modulated signal is applied to if. input (J525 or J526, fig. 55).	Faulty if. stage-----	Test if. stages by signal substitution method (par. 101). Test tubes. When necessary, localize fault by voltage and resistance measurements (figs. 66, 67, and 68).
5. If. circuits respond to 455-kc signal but no station is received.	Faulty mixers, oscillators, or rf stages. Vfo tuning shaft out of synchronization.	Test mixers stages, rf stages, vfo, and crystal oscillator by signal substitution method (par. 101).
6. No beat frequency heard when BFO switch is turned on and BFO PITCH control varied.	Faulty bfo-----	Test tube V508. Check synchronization. Check voltages at tube-socket pins (fig. 66). Check BFO switch.
7. Excessive hum from ac power supply.	Defective filter capacitor or electronic voltage regulator.	Adjust HUM BAL control R614 (par. 118). Check C103. Test tubes V605, V606, and V607 (par. 95). Check voltage across reference tubes V608 and V609. Check C607 for capacitance and leakage. Check voltage and resistance of electronic voltage regulator (fig. 67).
8. Weak signal-----	Low voltage. Weak tubes-----	Check power-input voltage. Check B+ voltage at J601 (fig. 60). Test tubes. Check for shorted capacitors. If no fault is indicated by a thorough check of tubes and voltages when the output is weak, aline tuning circuits (pars. 119 through 127).
9. Noisy receiver-----	Noisy antenna location. Poor connection or shorting elements within a tube.	Short-circuit antenna to ground. A considerable decrease in noise indicates noisy signal from antenna. Use insulated prod to tap each tube. If tapping a tube causes noise increase in the output, try different tube.
	Loose connection at a terminal or within a part.	Tap the parts. Move terminals slightly, and listen for noisy output. Noise indicates that a connection should be resoldered or that a part needs replacing.

Symptom	Probable trouble	Correction
10. Receiver output noisy when controls are operated.	Dirty switch contacts. Poor contact at rotor of a gain control. Dirty motor commutator.	Clean switch contacts. Clean and lubricate control, or replace. Clean or replace commutator.
11. Distorted signal.	Weak tube. Incorrect voltage on tube. Leaky capacitor, such as C603 or C610.	Check tubes and replace if necessary. Check voltage and resistance in af subchassis (fig. 67). Use headset connected in series with a .1- μ f capacitor to check signal across grid and plate circuits of audio stages to localize trouble.
12. Tuning motor completely inoperative.	Motor tune switch S204 has dirty or broken switch contacts. Shorted field or armature windings in motor B202.	Clean or replace contacts. Replace.
13. Tuning motor partially operative.	Motor B202 has dirty commutator or worn brushes. Power Supply PP-621/URR, 25.2V source low.	Clean commutator. Replace brushes. Increase line voltage, if low.
14. Band-switching motor completely inoperative.	Defective relay control tube V210 or component part. Motor control relay K201. Open or shorted windings. Bad relay contacts. 28-volt power supply. Defective rectifier CR401. T401 shorted or open. C401 shorted. S205 defective.	Replace tube or part. Replace relay. Replace rectifier. Replace transformer. Replace capacitor.
15. Tuning motor does not drive gear train.	Disk clutch not adjusted properly. Binding at Oldham coupler or dirty gears.	Clean and adjust or replace wipers. Adjust clutch arm (par. 117). Adjust coupler (fig. 64). Clean gears (par. 111a).
16. Frequency change knob does not drive gear train.	Knob slip clutch out of adjustment.	Adjust slip clutch (par. 116).
17. Band-switching does not occur, or is not properly synchronized.	Band - switching motor control switch S205 inoperative or not synchronized.	Repair or replace switch. Synchronize switch (par. 115).

100. Voltage and Resistance Checks

Voltage and resistance diagrams for the various subchassis of the receiver are shown in figures 66, 67, and 68. These drawings show the values that should be obtained at the tube-socket pins and terminal boards. If a value, as read on the multimeter, varies (outside of reasonable tolerance limits) from the value given in the diagrams, the amount of variance should be noted and used to determine which part is at fault. For instance, if a 100,000 ohm resistance is indicated at a given tube-socket pin on a diagram, and the actual indication is 30,000 ohms on the meter, the circuit diagram of the subchassis should be examined for the presence of a resistor in the circuit under test that could, if defective, account for the incorrect

indication. Such a resistor would then be suspected and should be checked. Another possibility would be that a capacitor has shorted out and is shunting a resistor. There are many ways of using the voltage and resistance diagrams, depending on the resourcefulness of the repairman.

Note. The measurements shown in figures 66, 67, and 68 were made with the FUNCTION switch in the AGC position. When making resistance measurements, be sure to remove the power cable from the ac source and leave the FUNCTION switch at AGC.

101. Signal Substitution Notes

a. Signal substitution for Radio Receiver R-389/URR requires an audio oscillator, such as Audio Oscillator TS-382/U, for checking the line

and local audio channels, and an rf signal generator, such as Signal Generator TS-588A/U, to provide a source of modulated signals for checking the rf and if. stages. In addition to producing an if. signal of 455 kc, the signal generator should cover an rf range of at least 15 kc to 11 mc. The signal generator should be capable of furnishing an rf signal output at any level between 1 microvolt (μv) and 1 volt.

b. A multimeter, such as Electronic Multimeter TS-505/U, and a tube tester, such as Electron Tube Test Set TV-2/U, are needed to isolate the defective part after the faulty stage has been indicated by signal substitution.

c. For the tests described in paragraphs 102 through 107, connect the ground lead of the audio oscillator or signal generator to the subchassis being tested, and connect the signal output lead through a capacitor (approx. .05 microfarad (μf)) to the point specified. The bench-testing information contained in paragraph 93 and the information contained in paragraph 95*a* indicate the method of preparing the subchassis for signal tracing.

d. Note the volume, and listen for distortion from the speaker or headset at various points in the signal-substitution procedure. Make certain that the LIMITER control is turned to 0 position; when turned on, it may be the cause of the distortion. When working back from the output to the input stages, decrease the output of the signal generator as much as possible. Compare the results with a receiver known to be in good condition.

e. Check the wiring and soldering in each stage during the procedure.

f. A tuning rack that is out of synchronization or a trimmer adjustment that is out of alignment may cause reduced output or may prevent any output. Synchronization of the rack tuning screws (par. 119) should be checked and the position of the rf and injection circuit band switches should be checked (par. 115) before the adjustment of individual tuning circuits (pars. 121 and 122) is attempted.

g. When trouble is localized in a given stage, first test the tube; then measure the voltage and resistance of the circuits of that stage (figs. 66, 67, and 68).

h. Trouble in a circuit or stage does not always change the voltage and resistance measurements at the tube socket. Instructions included in this

paragraph serve as a guide, and suggest other procedures, such as voltage and resistance measurements of individual parts.

i. When testing, remove only one tube at a time. Check the type number of the tube and test the tube; if it is not defective, return it to its proper socket before removing another tube.

j. At each step it is assumed that all previous steps were completed satisfactorily. Isolate and clear any trouble discovered before proceeding with next steps.

k. Refer to the notes in paragraph 95 while performing the tests.

102. Local-audio-channel Tests

(fig. 61)

a. Pin 5 of V603 (Plate of Local Af Output Tube). Apply an af signal to pin 5 of tube V603. Listen to the signal from a headset or speaker connected to the local audio output. The volume should be very low. If no signal is audible, check the connections to output transformer T602 (fig. 60), and test capacitor C604 for a short circuit.

b. Pin 1 of V603 (Grid of Local Af Output Tube). Apply the signal to pin 1 of V603. Listen for an increased output over that obtained in the preceding step (*a* above). If no signal is audible, test the tube and the voltages at the socket pins. When the signal is distorted or when there is a positive dc voltage on the control grid with respect to the chassis, test capacitor C603 for leakage.

c. Pin 1 of V602 (Plate of Local Af Amplifier). Connect the output of the generator to pin 1 of V602. If the signal output decreases, test capacitor C603.

d. Pin 2 of V602 (Grid of Local Af Amplifier). Turn the LOCAL GAIN control fully on. Apply the signal to pin 2 of V602. The output signal should be much louder than that obtained in the previous step (*c* above). If the signal is weak, check the tube and the voltages at the tube-socket pins (fig. 67).

103. Line-audio-channel Tests

Connect the headset to the LINE AUDIO output, terminals 12 and 14 of the rear terminal strip (fig. 7). After the LINE LEVEL meter has been checked with Multimeter TS-352/U, it may be used as an output indicator. Rely on the headset, however, to detect noise and distortion.

a. Pin 5 of V604 (Plate of Line Af Output Tube). Insert the audio-oscillator signal at pin 5

1ST R-F AMPL
V202
6BJ6

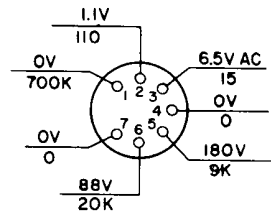

2D R-F AMPL
V203
6BJ6

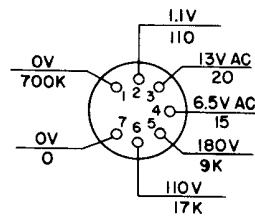

1ST MIXER
V204
12AT7

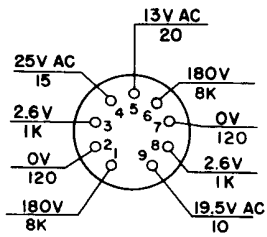

2D MIXER
V205
6BE6

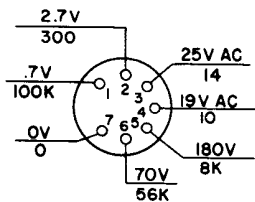

XTAL OSC
V207
6BH6

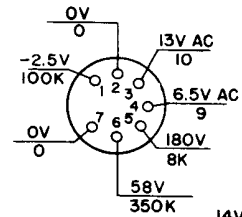

RELAY CONTROL
V210
6C4W

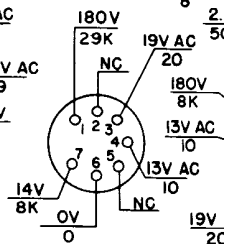

INJECTOR
V211
6BE6

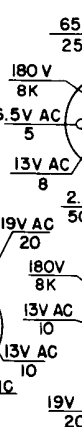

REAR

AGC RECTIFIER AND POSITIVE PEAK LIMITER
V510
12AU7

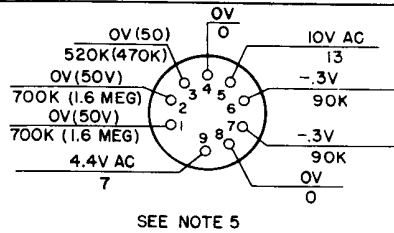

AGC AMPL
V509
6BJ6

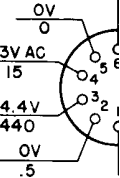
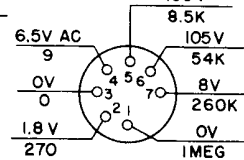

SEE NOTE 5

6TH I-F AMPL
V506
6AK6

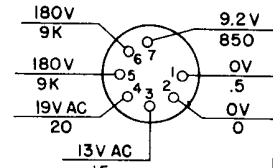

AGC TIME CONSTANT TUBE AND FOLLOWER
V511
12AU7

MIXER DRIVER
V206
6BH6

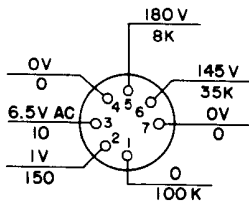

OUTPUT COUPLER
V209
6BH6

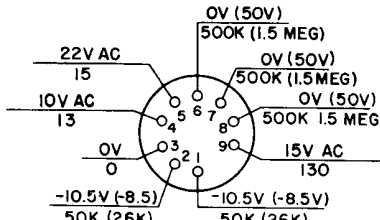
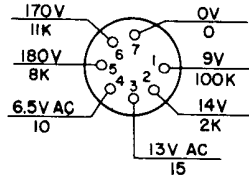

DETECTOR AND NEGATIVE PEAK LIMITER
V507
12AU7

(SEE NOTE 5)

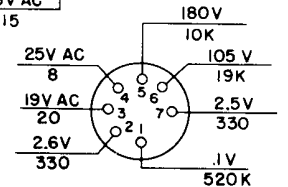

5TH I-F AMPL
V505
6BJ6

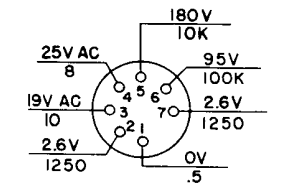

4TH I-F AMPL
V504
6BJ6

INJECTION MIXER
V213
6BE6

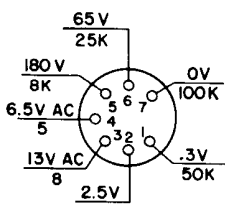

PHASE INVERTER
V211
6BH6

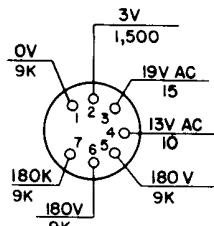

BFO
V508
5749
(SEE NOTE 6)

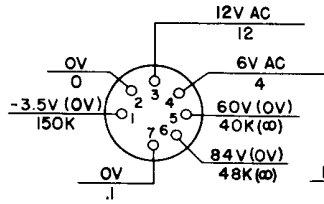

VOLTAGE REGULATOR
RT512
3TF7

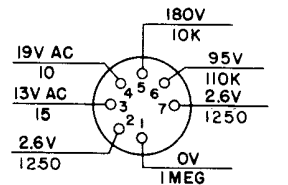
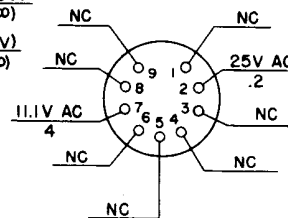

3D I-F AMPL
V503
6BJ6

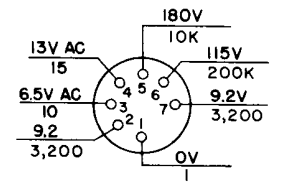

2D I-F AMPL
V502
6BJ6

INPUT COUPLER
V208
6BH6

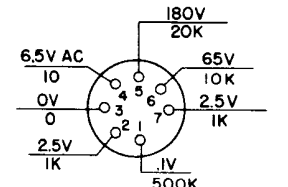
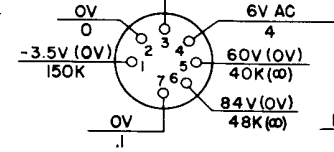

1ST I-F AMPL
V501
6BJ6

CONTROL

INJECTION MIXER
V212
6BE6

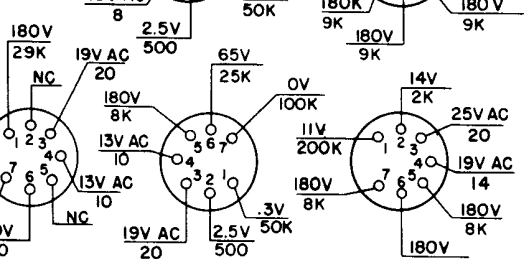

FRONT

Figure 66. Tube-socket voltages and resistances, top deck.

AGC AMPL
V509
6BJ6

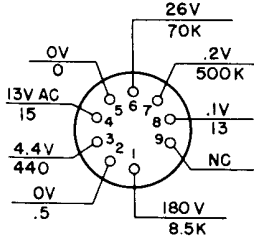
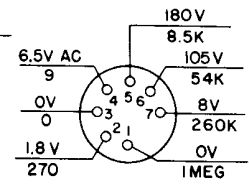

**AGC TIME CONSTANT
TUBE AND CATHODE
FOLLOWER**
V511
12AU7

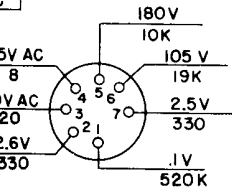
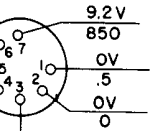

5TH I-F AMPL
V505
6BJ6

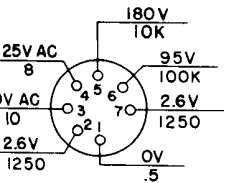

4TH I-F AMPL
V504
6BJ6

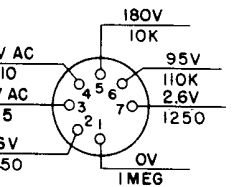

3D I-F AMPL
V503
6BJ6

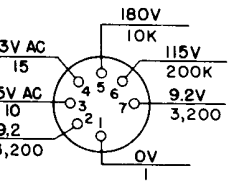

2D I-F AMPL
V502
6BJ6

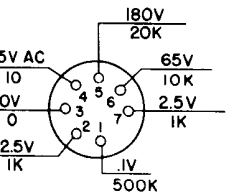

1ST I-F AMPL
V501
6BJ6

NOTES:

1. UNLESS OTHERWISE SHOWN,
RESISTANCES ARE IN OHMS AND WERE MEASURED FROM
SOCKET PIN TO GROUND.
VOLTAGES ARE DC AND WERE MEASURED FROM SOCKET
PIN TO GROUND WITH A VTVM.
READINGS ARE THE SAME ON ALL BANDS.
2. NC INDICATES NO CONNECTION.
3. ∞ INDICATES INFINITY.
4. UNLESS OTHERWISE NOTED, SET CONTROLS AS FOLLOWS:
FUNCTION TO AGC, AUDIO RESPONSE TO MEDIUM
RF GAIN TO 10, LOCAL GAIN TO 10, AND
BANDWIDTH TO BKC
5. READINGS IN PARENTHESIS ARE MADE WITH LIMITER AT
0 OTHER READINGS ARE WITH LIMITER AT 10
6. READINGS IN PARENTHESIS ARE MADE WITH BFO AT OFF

VOLTA
REGULA
V605
6082

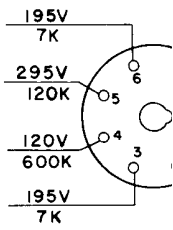
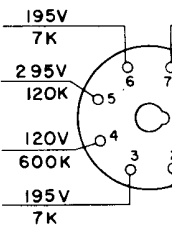

VOLTA
REGULA
V60
608

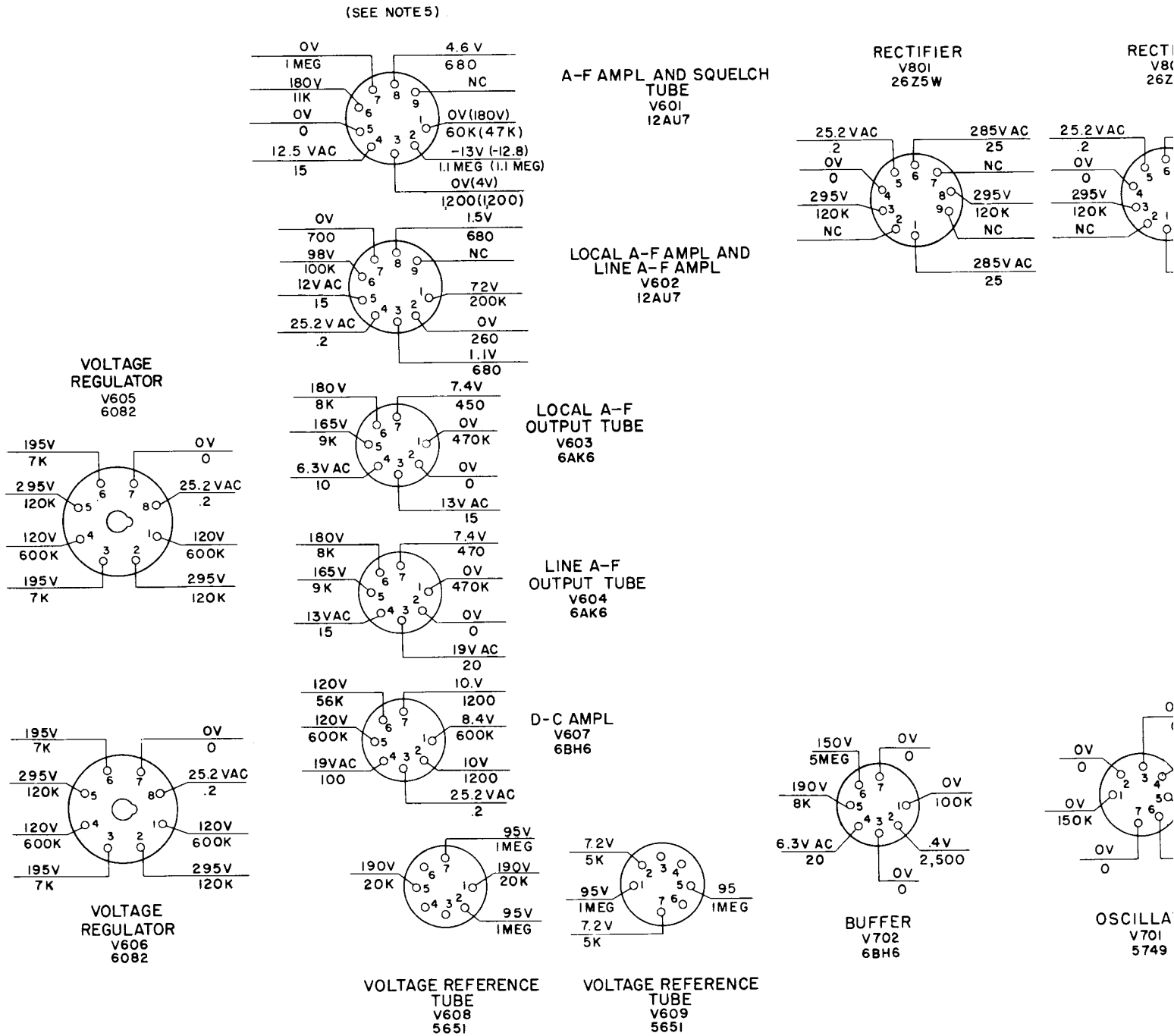
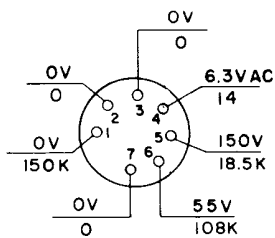
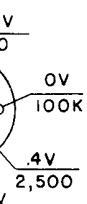
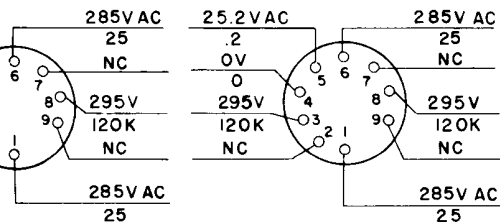

Figure 67. Tube-socket voltages and resistances

AMPLIFIER
V801
6Z5W

RECTIFIER
V802
26Z5W



OSCILLATOR
V701
5749

NOTES:

1. UNLESS OTHERWISE SHOWN, RESISTANCES ARE IN OHMS AND WERE MEASURED FROM SOCKET PIN TO GROUND. VOLTAGES ARE DC AND WERE MEASURED FROM SOCKET PIN TO GROUND WITH A VTVM. READINGS ARE THE SAME ON ALL BANDS.
2. NC INDICATES NO CONNECTION.
3. ∞ INDICATES INFINITY.
4. UNLESS OTHERWISE NOTED, SET CONTROLS AS FOLLOWS:
 [FUNCTION] TO [AGC], [AUDIO RESPONSE] TO [MEDIUM],
 [RF GAIN] TO [10], [LOCAL GAIN] TO [10],
 [BANDWIDTH] TO [8 KC] AND [LINE GAIN] TO [10]
5. READINGS IN PARENTHESIS ARE MADE WITH [FUNCTION] SWITCH AT [SQUELCH].

Tube-socket voltages and resistances, bottom deck.

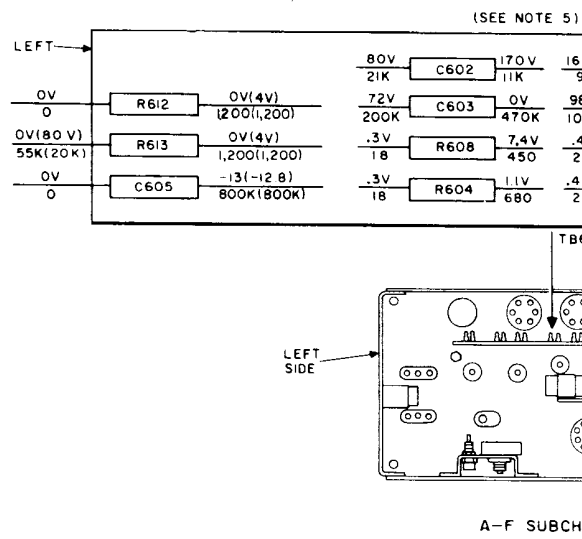
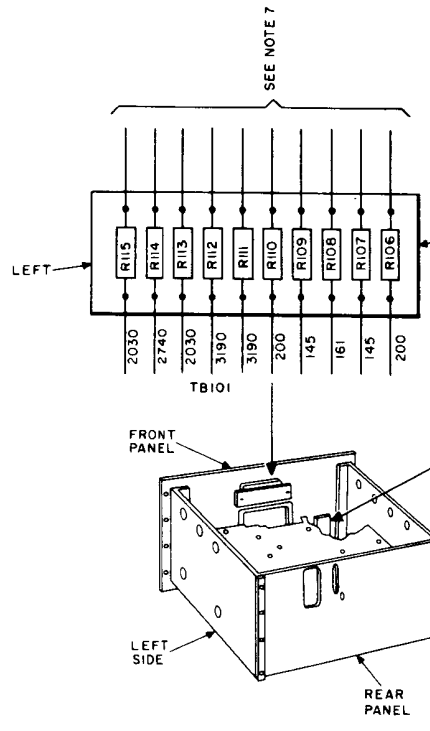

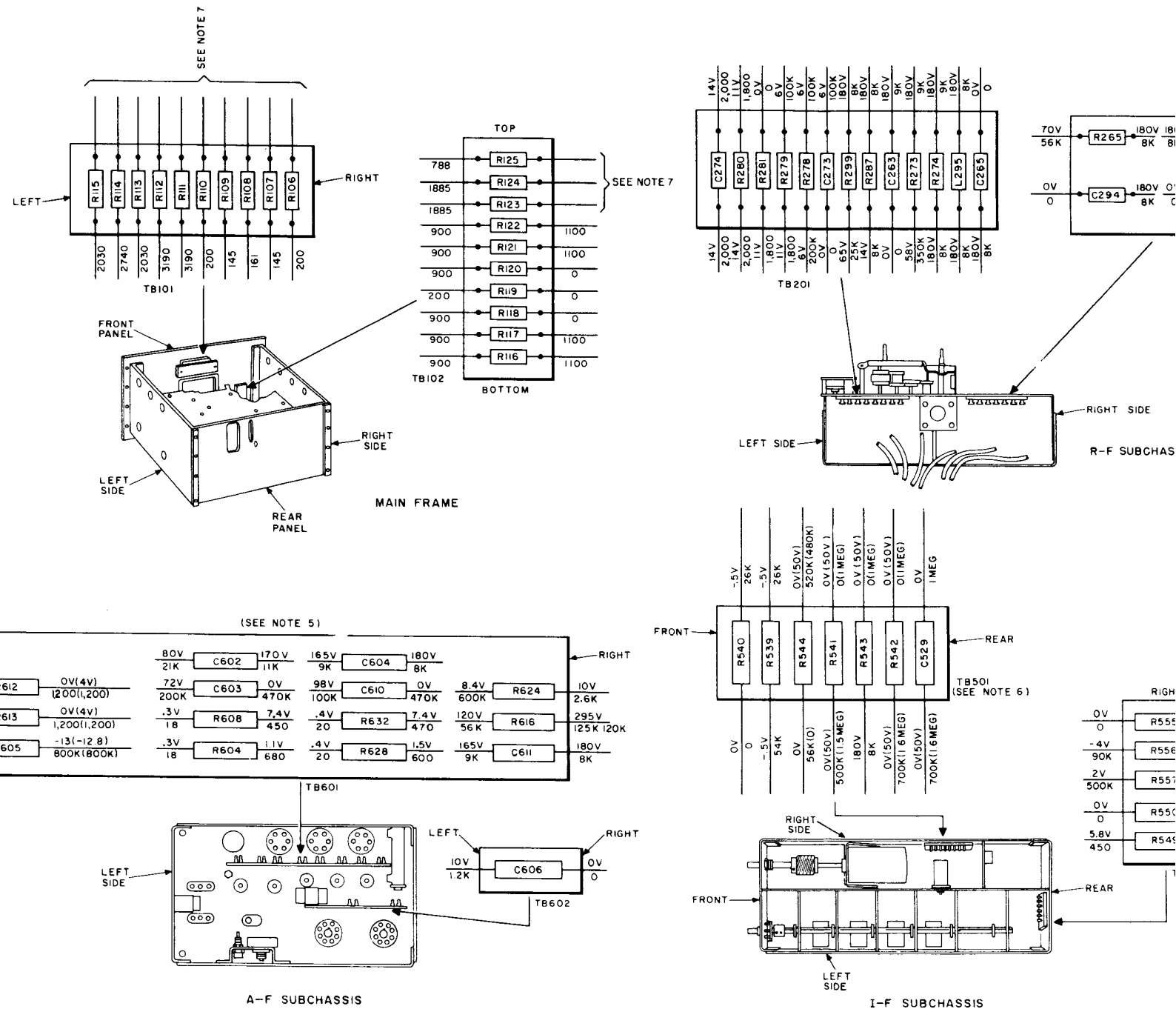

Figure 68. Voltages and resistances at terminal boards.

of V604. The volume should be very low, as heard in the headset. If no signal is audible, check the leads to output transformer T603 (fig. 60). The center leads of the secondary winding must be connected by a jumper between terminals 12 and 13 of the rear terminal strip (fig. 7). Test capacitor C611.

b. Pin 1 of V604 (Grid of Line Af Output Tube). Apply the signal to pin 1 of V604. The output signal should be much louder than that obtained in the previous step (*a* above). If the output is unsatisfactory, check the tube and the voltages at the tube-socket pins (fig. 67). If the grid bias is incorrect, as indicated by distortion or excessive plate current, check capacitor C610 for leakage. Check the operation of the LINE METER switch and the LINE LEVEL meter.

c. Pin 6 of V602 (Plate of Line Af Amplifier). Apply the audio-oscillator signal to pin 6 of V602. Rotate the LINE GAIN control to position 10. If the signal output decreases noticeably, test capacitor C610.

104. Af Amplifier Tests

a. Pin 6 of V601 (Plate of Af Amplifier). Introduce the signal from the audio oscillator at pin 6 of V601. Set the AUDIO RESPONSE switch to MEDIUM. The signal output should be somewhat less than that obtained when the signal was applied to pin 7 of V602. If no signal is heard, or if the signal is weak, check capacitor C602 for a short circuit and check transformer T601 for proper connections and shorted or open windings. Also inspect AUDIO RESPONSE switch S106 (fig. 64) for shorts and proper connections, and measure the resistance of band-pass filters FL601 and FL602 (fig. 60).

b. Pin 7 of V601 (Control Grid of Af Amplifier). Apply the signal to pin 7 of V601 (fig. 61). The output signal should be much louder than that obtained in the preceding step (*a* above). If the signal is weak, test the tube and the voltages at the tube-socket pins (fig. 67).

105. If. Subchassis Tests

a. Pins 1 and 2 of V510 (Plate of Positive-Peak Limiter). Introduce an af signal at pins 1 and 2 of V510 (fig. 56). If no signal is audible, or if the signal is weak, check capacitor C529. Check the seating of connectors P117 and P119 in connectors J517 and J619 (figs. 55 and 60).

b. Pin 3 of V510 (Cathode of Positive-Peak Limiter). Apply the af signal to pin 3 of V510 (fig. 56). A weak signal may indicate that V510 is defective or that resistor R542 or R544 is open (fig. 57).

c. Pins 6 and 7 of V507 (Plate of Negative-Peak Limiter). Apply the af signal to pins 6 and 7 of tube V507 (fig. 56). If the signal is weak, check V507 and resistor R541 (fig. 57).

d. Pins 1 and 2 of V507 (Plate of Detector). Introduce a 455-kc modulated signal from the signal generator at pins 1 and 2 of V507 (fig. 56). If there is no output signal, or if the signal is weak, check the tube and the jumper connection between terminals 15 and 16 of the rear terminal strip (fig. 7). If the trouble continues, check the voltage and resistance of the circuit component parts (fig. 66).

e. Pin 5 of V506 (Plate of Sixth If. Amplifier). Apply the 455-kc modulated signal to pin 5 of V506 (fig. 56). A weak output signal may indicate that transformer T506 is not aligned properly or that it has an open or short-circuited winding.

f. Pin 1 of V506 (Grid of Sixth If. Amplifier). Apply the signal to pin 1 of V506 (fig. 56). The output signal should be somewhat louder than that obtained in the preceding step. If the signal is weak, check the tube and tube-socket voltages (fig. 66). Test cathode-bypass capacitor C523 and screen-grid capacitor C524 (fig. 56) for an open circuit by temporarily shunting capacitors of like value across them.

g. Pins 5 and 1 (Plate and Grid of First Five If. Amplifiers). Set the FUNCTION switch at MGC, turn the RF GAIN control to position 10, and set the IF. BANDWIDTH switch at the 4-KC position. Apply the 455-kc modulated signal in turn to pins 5 and 1 of the first five 455-kc if. amplifiers, proceeding from the fifth stage back to the first (fig. 56). Correct any faults found in a stage before proceeding to the next stage.

106. Rf Subchassis Tests

a. Pin 5 of V205 (Plate of Second Mixer). Introduce a 455-kc modulated signal to pin 5 of V205 (fig. 49). If no signal is heard, check transformer T218 (fig. 77) for shorted or open windings and for proper alignment. Inspect plugs P223, P224, P225, and P226 (fig. 70) for proper seating on the rf and if. subchassis. Check the coaxial connecting cables for shorts and conductor continuity.

b. Pins 1 and 7 of V205 (Injection Grid and Signal Grid of Second Mixer). Apply a modulated 10-mc signal to pin 7 of V205 (fig. 50). If no audio output is heard, apply an unmodulated 1-volt, 10,455-kc signal to terminal 1 of V205. If atmospheric noise or an incoming signal is heard when the signal generator is connected, but disappears when the generator is disconnected, injection voltage is not being fed to the second mixer from crystal oscillator V207 (fig. 49). Apply the unmodulated signal to pin 5 of V207. If a signal or atmospheric noise appears, check the tube V207, its socket voltages, and 10, 455-kc crystal Y201 (fig. 49). Check 100,000-ohm grid resistor R272. If neither noise nor signal is heard when the test signal is applied to pin 5 of V207, check coupling capacitor C254 and second mixer injection grid resistor R263.

c. Pins 1 and 6 of V204 (Plates of First Mixer). Introduce a modulated 10-mc signal at pin 1 of V204 (fig. 49). If no audio output is heard, the 10-mc if. transformer T216 (fig. 77) or the associated connections are defective. Apply the signal to terminal 6 of V204. If no audio signal is heard, check connections to the plate and transformer.

d. Pins 2 and 7 of V204 (Grids of First Mixer). Tune the receiver to 15 kc. Apply a modulated 15-kc signal to pins 2 and 7 of V204 (fig. 50). If the signal is not audible, measure the rf voltage from test jack J237 (fig. 49) to ground. If the voltage measured is less than .5 volt ac, the injection voltage circuits are defective, and the tests described in *e* through *i* below should be performed. When the injection voltage is sufficient (normally 1 to 2 volts), test first mixer tube V204 and check its socket voltages. Apply a 1-volt, 9,985-kc unmodulated signal to test jack J237 and couple an antenna through a .01- μ f capacitor to either pin 2 or 7 of tube V204. Signal or noise output indicates incorrect frequency of the injection voltage. Check band switch S201 and range switch S203 (fig. 51) for low- and high-frequency synchronization. Check the mechanical linkage between S102 and S203.

e. Pins 1 and 2 of V206 (Control Grid and Cathode of Mixer Driver). With the receiver tuned to 15 kc, apply a 1-volt, 9,985-kc unmodulated signal to pin 2 of V206 (fig. 49). Measure the rf voltage at test jack J237. If no voltage indication is obtained, check transformer T215 (fig. 51). In-

troduce the test signal at pin 1 of V206. If no rf voltage is present at jack J237, check the tube V206 and the voltages and resistances of the tube circuits.

f. Pins 2 and 5 of V209 (Plate and Cathode of Output Coupler). Apply an unmodulated 9,985-kc signal to pin 5 of V209 (fig. 49). Measure the rf voltage at test jack J237. If no voltage is present, check coupling capacitor C258 (fig. 51), switch section S203C, and plate tuning circuit Z215 (fig. 49). Inject the test signal at terminal 2 of V209. If a voltage indication is not obtained at jack J237, check tube V209, and the voltages and resistance values at its pins. When the receiver operates in the low range, but is inoperative in the high range, tune the receiver to 1,500 kc, and then use a test signal of 8,500 kc instead of 9,985 kc to perform the checks described in *a* through *e* above. Plate tuning circuit Z216 (fig. 49) replaces Z215 when the receiver is operated in the high range of frequencies.

g. Pins 1 and 2 of V208 (Control Grid and Cathode of Input Coupler). Tune the receiver to 15 kc. Apply an unmodulated 9,985-kc signal to pin 2 of V208 (fig. 49). Measure the rf voltage at test jack J237. If no voltage is present, check low-pass filter FL201 (fig. 49) and coupling capacitor C274 (fig. 50). Introduce the signal at pin 1 of V208; if no voltage is present at jack J237, check the voltages and resistance values at the tube socket.

h. Pins 1 and 5 of V212 or V213 (Injection Grids and Plates of Injection Mixers). Apply an unmodulated 9,985-kc signal to terminal 5 of tube V212 or V213 (fig. 49). If rf voltage is not present at test jack J237, check coupling capacitor C272, the contacts of switch section S203A, and plate tuning circuit Z219 (fig. 49). Perform the following test when the low-frequency range is operative while the high-frequency range is inoperative. Tune the receiver to 1,500 kc, and use a test frequency of 8,500 kc, to check plate tuning circuit Z220 (fig. 49). If rf voltage is measured at test jack J237, remove the test signal from pin 5 and apply a 1-volt, 10,455-kc unmodulated signal to pin 1 of either tube V212 or V213. If rf voltage now appears at test jack J237, check crystal-oscillator output transformer T217 (fig. 49).

i. Pins 2 and 5 of V211 (Cathode and Plate of Phase Inverter). With the receiver tuned to 15 kc, apply a 1-volt, 470-kc unmodulated signal to

pin 5 of tube V211 (fig. 49). Measure rf voltage at test jack J237. If no voltage is present, check coupling capacitor C288. Inject the test signal at pin 2 of V211. If rf voltage does not appear at J237, check coupling capacitor C289.

j. Pin 1 of V211 and Plug P230 (Control Grid and Input Cable Plug of Phase Inverter). Apply a 1-volt, 470-kc unmodulated signal to pin 1 of tube V211. Measure rf voltage at test jack J237. If no voltage is present, test tube V211 and check the voltage and resistances of the stage. Insert the 470-kc signal at phase inverter input cable plug P230. If rf voltage is not present at jack J237, check tuning circuit Z218 (fig. 49), switch section S203B, and coupling capacitor C286. If the receiver is operative on the low band but inoperative on the high band, change the frequency reading of the receiver from 15 kc to 1,500 kc, change the test signal from 470 kc to 1,995 kc, and perform the tests described above in *a* through *i* above. However, check tuning circuit Z217 rather than Z218 (fig. 49).

k. Pin 5 of V203 or Test Jack J232 (Plate of Second Rf Amplifier). Tune the receiver to 1,180 kc. Apply a modulated 1,180-kc signal to pin 5 or test jack J234 of tube V203 (fig. 53). If no output signal is audible, check the contacts of switch sections S201G, S201H, and S201J, capacitor C247 (fig. 51), and rf transformer T214 (fig. 50). When the receiver is inoperative over only part of its tuning range, perform similar tests at the following frequencies: 680 kc, 370 kc, 180 kc, 90 kc, 40 kc, and 20 kc. Tune the receiver and the signal generator to each frequency successively. Be sure that the automatic rf band-switching system connects the proper capacitor and transformer combination for each band. Refer to figures 49, 50, and 51 for the location of parts mentioned in the remainder of this paragraph. When the test is performed at the 680-kc frequency, check capacitor C246 and transformer T213; at 370 kc, capacitor C245 and transformer T212; at 180 kc, capacitor C244 and transformer T211; at 90 kc, capacitor C243 and transformer T210; at 40 kc, capacitor C242 and transformer T209; and at 20 kc, capacitors C240 and C241, and transformer T208.

l. Pin 1 of V203 (Control Grid of Second Rf Amplifier). With the receiver tuned to 1,180 kc, apply a modulated test signal of the same frequency to pin 1 of tube V203 (fig. 53). If no output signal is heard, test tube V203 and check the

stage for proper voltage and resistance measurements.

m. Pin 5 of V202 or Test Jack J232 (Plate of First Rf Amplifier). While the receiver is tuned to 1,180 kc, inject a modulated test signal of the same frequency at pin 5 of tube V202 (fig. 53). If no output is audible, check the contacts of switch sections S201E and S201F, capacitor C235 (fig. 51), tuning circuit Z214 (fig. 49), and coupling capacitor C237 (fig. 54). If the receiver is inoperative over a part of its tuning range, check the individual tuning circuits as described in *k* above for the second rf amplifier stage. Consult figures 49, 50, and 51 for the location of parts mentioned in the remainder of this paragraph. At the 680-kc frequency, check capacitor C234 and tuning circuit Z213; at 370 kc, capacitor C233 and Z212; at 180 kc, capacitor C232 and Z211; at 90 kc, capacitor C231 and Z210; at 40 kc, capacitor C230 and Z209; and at 20 kc, capacitors C228 and C229, and tuning circuit Z208.

n. Pin 1 of V202 or Test Jack J231 (Control Grid of First Rf Amplifier). Check tube V202 (fig. 53) and its associated circuits as described for V203 in *l* above.

o. Balanced Antenna Input Circuit (Receptacle J106). Ground one contact of ANTENNA BALANCED 125 OHM receptacle J106 (fig. 7). Connect the 1,180-kc output of the signal generator to the remaining contact. If no signal is audible, check coupling capacitor C224 (fig. 54); switch sections S201A, S201B, and S201D; coaxial connecting cables; and antenna input bypass capacitor C106 (fig. 72). Be sure that antenna relay K101 (fig. 72) is not activated. If an antenna circuit for a particular band is defective, check the coupling resistor that connects the antenna transformer for that band to its succeeding tuned circuit. At a frequency of 1,180 kc, check antenna transformer T207 (fig. 49), capacitor C212 (fig. 51), resistor R209 (fig. 51), tuned circuit Z207 (fig. 49), and capacitor C223 (fig. 51). Refer to figures 49, 50, and 51 for location of parts mentioned in the remainder of this paragraph. At 680 kc, check transformer T206, capacitors C210 and C211, resistor R208, tuned circuit Z206, and capacitor C222; at 370 kc, check transformer T205, capacitors C208 and C209, resistor R207, tuned circuit Z205, and capacitor C221; at 180 kc, check transformer T204, capacitors C206 and C207, re-

sistor R206, tuned circuit Z204, and capacitor C220; at 90 kc, check transformer T203, capacitors C204 and C205, resistor R205, tuned circuit Z203, and capacitor C219; at 40 kc, check transformer T202, capacitor C203, resistor R204, tuned circuit Z202, and capacitor C218; at 20 kc, check transformer T201, capacitors C201 and C202, resistor R203, tuned circuit Z201, and capacitors C216 and C217.

p. Unbalanced Antenna Input Circuit (J105). When the balanced antenna input circuits function properly, while the unbalanced circuits are inoperative, check ANTENNA UNBALANCED input receptacle J105 (fig. 7), capacitor C105 (fig. 72), antenna relay K101, coaxial connecting cable, and switch section S201C. Test the unbalanced input in the same manner as for the balanced circuits (*o* above) excluding switch sections S201A and S201B, and the primary windings of transformers T201 through T207.

107. Vfo Subchassis Tests

Warning: Do not remove the sealed covers from the vfo tuning circuits or oven unless retuning and resealing equipment is available.

a. Pins 5 and 1 of V702 (Plate and Control Grid of Buffer). Tune the receiver to 15 kc. Apply a 1-volt, unmodulated 470-kc test signal to pin 5 of tube V702. Measure rf voltage at test jack J237. If no voltage is present, check the coaxial connecting cable. Inject the 470-kc test signal at pin 1 of tube V702. If no rf voltage appears at jack J237, test tube V702, and check the voltage and resistance of the stage circuits.

b. Pins 5 and 1 of V701 (Plate and Control Grid of Vfo). Apply the 470-kc test signal to pin 5 of tube V701. If rf voltage is not present at test jack J237, check coupling capacitor C711 (fig. 58). Apply the test signal to pin 1 of V701. If no rf voltage appears at J237, test tube V701, and check the voltage and resistances at its pin sockets.

108. Dc Resistances of Transformers and Coils

The dc resistances of the transformer windings, relay windings, and coils in Radio Receiver R-389/URR and in Power Supply PP-621/URR, as measured with an ohmmeter (such as that incorporated in Multimeter TS-352/U), are listed below. The resistances were measured with the subchassis removed from the main frame.

a. Radio Receiver R-389/URR.

Part No.	Terminals	Ohms
FL201	1-3	1.2
K101	1-2	17
K201	1-10	20K
L286		8
L294		8
L295		8
L304		20
T201	1-3	13
	2-4	6
T202	1-3	15
	2-4	3.5
T203	1-3	16
	2-4	2.5
T204	1-3	12.5
	2-4	2.8
T205	1-3	5.5
	2-4	1
T206	1-3	1.8
	2-4	Less than 1
T207	1-3	1.2
	2-4	Less than 1
T208	1-3	13.5
	2-4	17.5
T209	1-3	16
	2-4	3.4
T210	1-3	16.5
	2-4	3
T211	1-3	12.5
	2-4	2.3
T212	1-3	5.5
	2-4	1.8
T213	1-3	1.8
	2-4	Less than 1
T214	1-3	1.2
	2-4	Less than 1
T215	J237 to gnd	1
	Pin 2 of V206 to R267	Less than 1
T216	2-1	Less than 1
	1-3	Less than 1
T217		Less than 1
T218	J223 to J224	2.2
	1-5	5
Z201	1-3	13.5
Z202		16
Z203		16
Z204		12
Z205		5.5
Z206		2
Z207		1.3
Z208		13.5
Z209		16.5
Z210		16
Z211		13
Z212		5.5
Z213		2
Z214		1.2
Z215		Less than 1
Z216		Less than 1

a. Radio Receiver R-389/URR—Continued

Part No.	Terminals	Ohms
Z217	-----	Less than 1
Z218	-----	1
Z219	-----	Less than 1
Z220	-----	Less than 1
T401	1-2	60
	3-4	60
	5-6	450
L501	-----	7
L502	-----	45
L503	-----	7
T501	2-9	Less than 1
	3-7	Less than 1
	3-10	Less than 1
	4-10	Less than 1
	5-10	Less than 1
	6-10	Less than 1
T502-505	2-9	Less than 1
	3-7	Less than 1
	3-10	Less than 1
	4-10	Less than 1
	5-10	Less than 1
	6-10	Less than 1
T506	8-10	Less than 1
	1-2	Less than 1
	1-9	1
	4-6	1.2
Z501	-----	5
Z503	-----	6.5
Z502	C532 through coil to pin 7 of V508.	2
	Pin 7 of V508 through coil to ground.	Less than 1
FL601	IN-OUT	50
	IN-GND	25
	OUT-GND	25
FL602	IN-OUT	39
	IN-GND	00
	OUT-GND	00
K601	4-5	10K

a. Radio Receiver R-389/URR—Continued

Part No.	Terminals	Ohms
K602	3-4	17
L601	-----	90
T601-603	1-2	900
	3-4	27
	5-6	31

b. Power Supply P-621/URR.

Part No.	Terminals	Ohms
T801	1-2	Less than 1
	3-4	Less than 1
	8-10	Less than 1
	5-7	50
	-----	-----

109. B+ Voltage Distribution
(fig. 87)

The input voltage from the power line to the power supply is controlled by FUNCTION switch S107. In addition, this switch also controls the application of B+ to the various circuits, with the exception of variable frequency oscillator V701. B+ is always connected to the vfo, so that the temperature of the parts will remain constant. In the MGC and AGC positions of S107, regulated B+ voltage is applied to all circuits of the receiver except the squelch circuit. In the SQUELCH position, B+ is connected to all receiver circuits as well as the squelch circuit (section B of V601). In the STAND BY position, all B+ circuits except that of the vfo are disconnected.

Section II. REPAIRS

110. Removal and Replacement

Caution: Before beginning any disassembly, set the **FREQ RANGE** control to the 15-500 KC position and turn the **FREQ CHANGE** control to the lowest frequency the counter will register. Make a note of the reading on the counter. Turn the **FREQ RANGE** control to the 500-1500 KC position and turn the **FREQ CHANGE** control to the highest frequency the counter will register. Make a note of the reading on the counter. Use of these readings is necessary when certain of the subchassis are replaced. Because the 52-turn stop

is located on the vfo chassis, do not turn the **FREQ CHANGE** control too high or too low when it is not mechanically coupled to the vfo tuning shaft.

Directions for removing and replacing the subchassis and various smaller parts of the receiver for bench-testing and repair are listed in *a* through *v* below. Subchassis mounting screws have green heads. In most cases they are captive screws. To free the subchassis, loosen these screws only until they are free of the main frame. When replacing the subchassis, the captive screws should be started one at a time to position the subchassis properly before tightening them all the way. Co-

axial plug reference designations are marked on bands fastened to the cables near the plugs. To remove a coaxial plug, press the plug slightly and twist it counterclockwise to release it; then pull the plug straight out. Where coaxial plugs are not readily accessible, scissors-type Tube Puller TL-201, supplied with Tool Set TE-41, can be used for removal of the plugs. To remove 7-pin plug P731 (fig. 71) from jack J131, first turn the metal shield counterclockwise and then pull the plug. When replacing multicontact plugs, be sure that the pins are properly aligned with the receptacle contacts, because the pins are easily bent. When loosening clamp screws, be careful not to overdraw the screws. Do not tighten clamp screws too far, because the threads may be stripped. Make sure that the Bristo wrench is fully inserted into the screw to avoid stripping the slots in the head.

a. Removal of Front Panel (figs. 69, 70, and 71). To reach to the wiring and parts on the back of the front panel, proceed as follows:

- (1) Remove the top and bottom dust covers from the receiver.
- (2) Disconnect plugs P127, P128, and P129 (figs. 70 and 71).
- (3) Place wooden blocks under the side plates of the receiver main frame, in back of the front panel, so that the panel is clear of the bench and the receiver is tilted backwards.
- (4) Position the BFO PITCH control at 0. Position the IF. BANDWIDTH switch so that the screw in the collar is accessible.
- (5) Make a note of the control positions ((4) above) and of the FREQ RANGE setting and the FREQ CHANGE dial reading.
- (6) Tighten the DIAL LOCK and turn the FREQ CHANGE to slip the clutch until the hole in the skirt of the knob is in line with a set screw. Loosen the set screw. Remove the FREQ CHANGE knob. Loosen the set screws in the MOTOR TUNE and DIAL LOCK knobs. Remove the knobs.
- (7) Loosen the set screws in the couplers (behind the panel) for the BFO PITCH and IF. BANDWIDTH controls. Pull the shafts forward to disengage them from the shafts on the subchassis.
- (8) Remove the eight flat-head panel mounting screws. Carefully pull the panel straight out to clear the control shafts, and lay the panel face down in front of the main frame.

Caution: Do not allow the main frame to drop on the panel-mounted switches, and handle it carefully to prevent breaking wires and switch contacts.

b. Replacement of Front Panel. To replace the front panel, proceed in the reverse order of removal; be sure that the extension on the FREQ RANGE shaft is seated properly.

c. Removal of If. Subchassis (fig. 70). To remove the if. subchassis, proceed as follows:

- (1) Remove the top dust cover from the receiver.
- (2) Rotate the IF. BANDWIDTH control so that the clamp that secures the control shaft behind the panel is accessible. Make a note of the control setting.
- (3) Set the BFO PITCH control at 0.
- (4) Loosen the clamp set screws on the IF. BANDWIDTH and BFO PITCH control shafts, and uncouple the shafts by pulling outward on the control knobs.
- (5) Disconnect coaxial connectors P112, P225, and P226 from J512, J525, and J526.
- (6) Disconnect plug P117 from J517.
- (7) Loosen the three green color-coded captive screws, one at the front-center of the subchassis and two at the rear corners.
- (8) Lift the subchassis straight up from the receiver. Do not disturb the positions of the BFO PITCH and IF. BANDWIDTH tuning shafts after the subchassis is removed from the receiver, unless necessary for performing tests.

d. Replacement of If. Subchassis. To replace the if. subchassis, follow the removal procedure (*c* above) in reverse order. Before recoupling the IF. BANDWIDTH and BFO PITCH control shafts, be sure that the controls are set at the position noted during removal. Check the calibration of the bfo (par. 126).

e. Removal of Rf Subchassis (fig. 70). To remove the rf subchassis, proceed as follows:

- (1) Remove coaxial connectors P209, P210, and P211 (fig. 71) from J109, J110, and J111 on the main frame. Disconnect

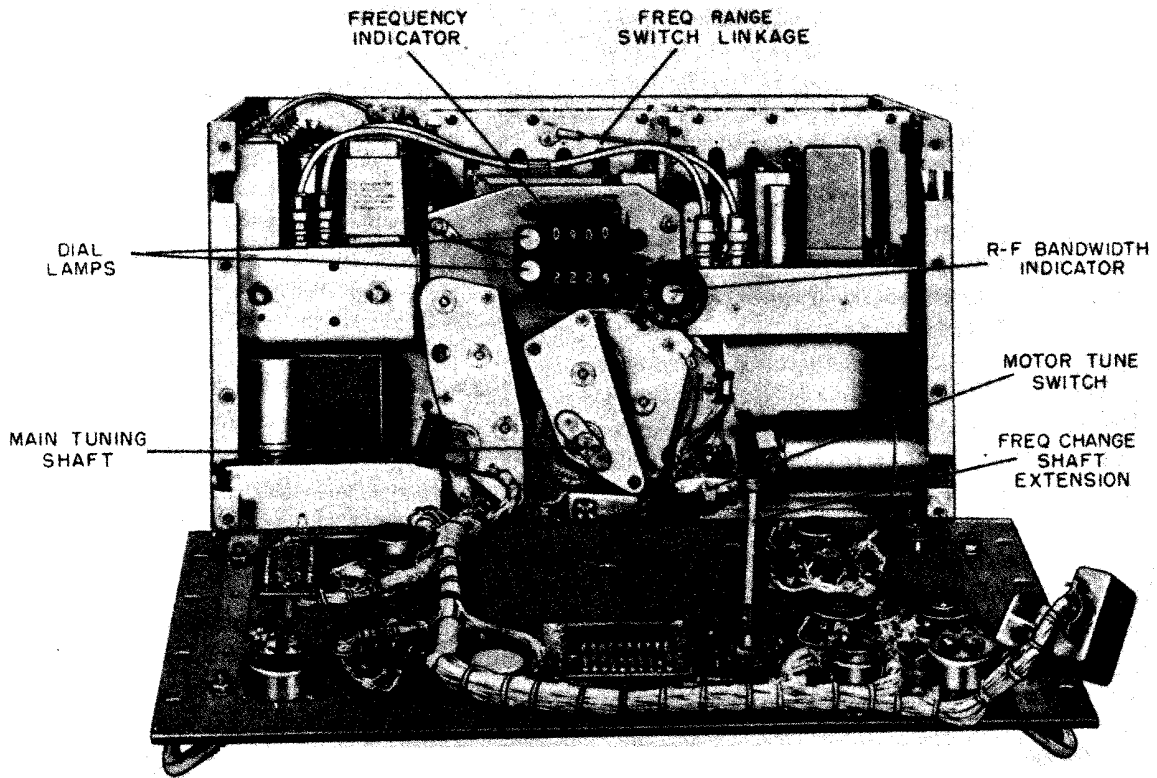

TM 655-80

Figure 69. Front view, front panel removed.

- (1) Remove the coaxial connector P230 (fig. 71) from P730 at the vfo. Remove coaxial cables terminated by P223 and P224 (fig. 70) from the receiver. Remove P129 from its jack.
- (2) Remove the clamping bar (fig. 71) by removing the screws. Remove the two roundhead green screws in the main frame side panel and the similar screw in the rear panel.
- (3) Remove the front panel as described in *a* above.
- (4) Remove the if. subchassis as described in *c* above.
- (5) Loosen the captive screws in the base of the unit. One captive screw is reached through the hole between tube V213 and crystal Y201 (fig. 70); the remaining screws are reached through the holes marked H202 at the front and rear of the tuning racks (fig. 70).

- (6) Make sure that the coaxial connector plugs are free to travel through the holes in the main frame. Pull the rf subchassis slightly forward to disengage the vfo coupling, and lift the subchassis straight up.

f. Replacement of Rf Subchassis. To replace the rf subchassis, proceed as follows:

- (1) Coat the Oldham coupler flange (fig. 64) lightly with grease and replace the notched coupling washer on the flange.
- (2) Obtain the aid of a second person to pull coaxial cables completely through the holes in the main frame.
- (3) Follow the removal procedure in reverse order (*e* above).

g. Removal of Rf Amplifier Subassembly (fig. 71). Loosen the four green captive screws located at the subassembly corners. Carefully lift the subassembly straight out from the rf subchassis.

h. Replacement of Rf Amplifier Subassembly.

To replace the rf amplified subassembly, follow the removal procedure (*g* above) in reverse order.

i. Removal of Af Subchassis (fig. 71). To remove the af subchassis, proceed in the following manner:

- (1) Remove the bottom dust cover from the receiver.
- (2) Disconnect plugs P119 and P120 from J619 and J620.
- (3) Loosen the three green captive screws, one at the front end of the subchassis and two at the rear corners.
- (4) Lift the subchassis straight up from the receiver.

j. Replacement of Af Subchassis. To replace the af subchassis, follow the removal procedure (*i* above) in reverse order.

k. Removal of Power Supply PP-621/URR (fig. 71). To remove Power Supply PP-621/URR, proceed in the following manner:

- (1) Remove the bottom dust cover from the receiver.
- (2) Disconnect large connector P118 from J818 (fig. 71).
- (3) Loosen the two captive screws (H802) (fig. 62) accessible through holes indi-

cated by arrows marked MTG SCREWS INSIDE.

- (4) Loosen the green captive screw located in the corner of the subchassis near tube V802.
- (5) Remove the four screws that secure the power transformer to the side of the main frame. These screws are $\frac{7}{16}$ inch long; make sure that only these screws are used when replacing the subchassis.
- (6) Lift the subchassis straight up from the receiver.

l. Replacement of Power Supply PP-621/URR. To replace the power supply subchassis, follow the removal procedure (*k* above) in reverse order. When tightening the retaining screws, start the screws in the following order: the two hidden screws, the one captive screw, and then the four $\frac{7}{16}$ -inch screws.

m. Removal of Vfo Subchassis (fig. 71). To remove the vfo subchassis, proceed as follows:

- (1) Remove the bottom dust cover of the receiver.
- (2) Disconnect plug P731 and coaxial connector P230 from J131 and P730. Note

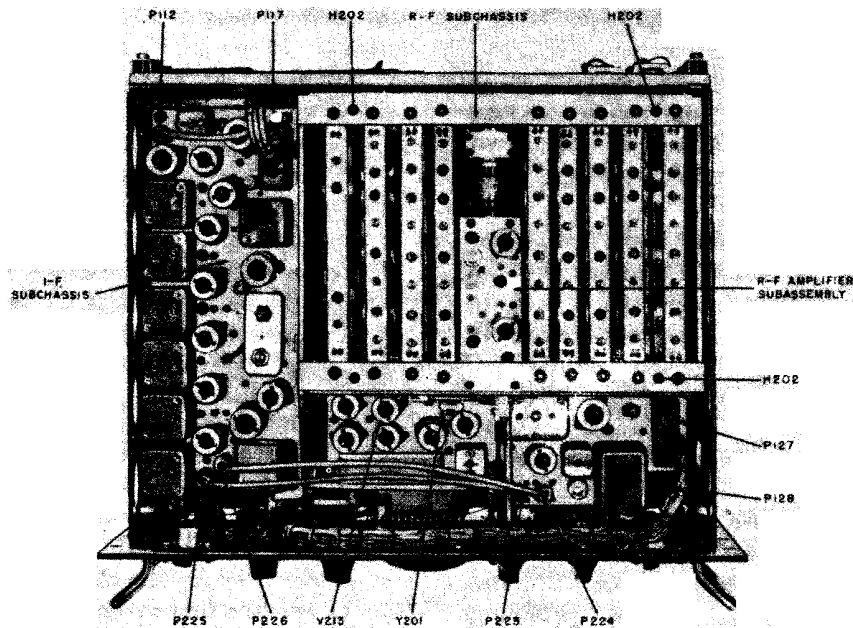

TM 855-81

Figure 70. Top view, dust cover and shield removed.

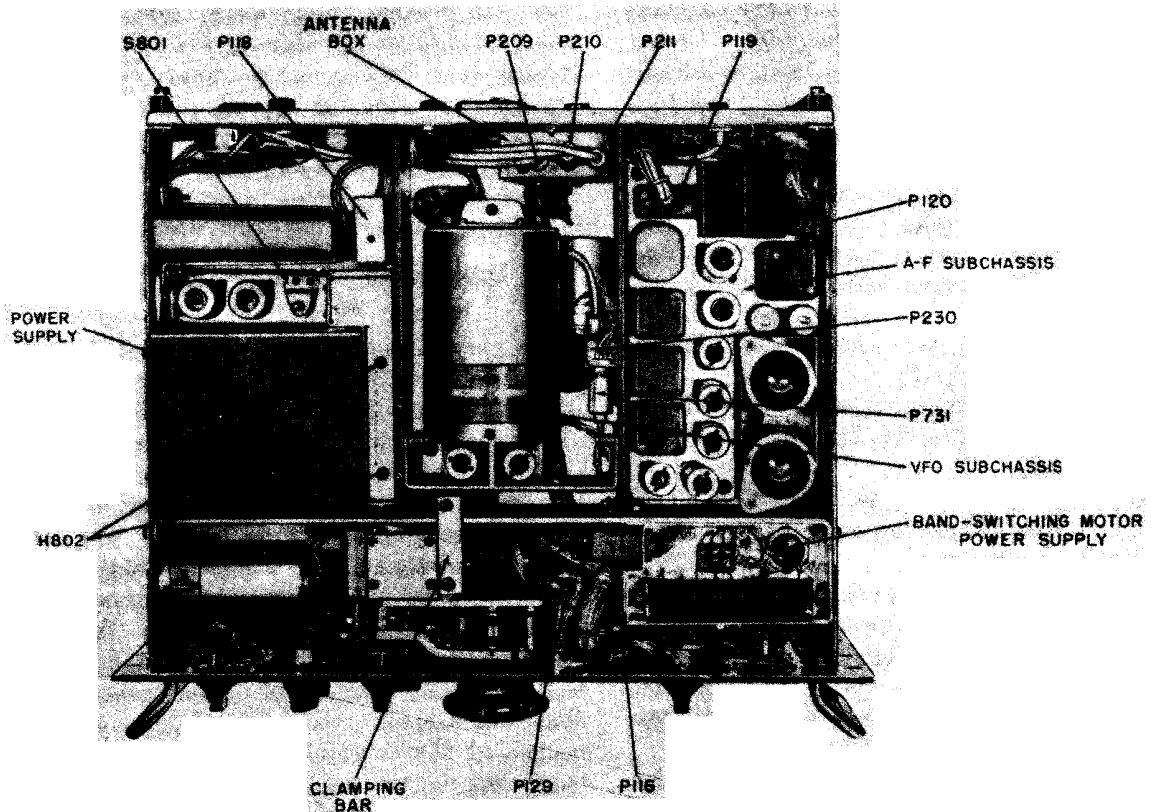

TM855-B2

Figure 71. Bottom view, dust cover removed.

that P731 has a locking device which must be rotated before removal of plug.

- (3) Rotate the **FREQ CHANGE** control until the ridge in the Oldham coupler flange nearest the vfo subchassis is vertical.

Note. If synchronization of the vfo tuning shaft and **FREQ CHANGE** control is to be maintained, do not disturb the position of the shaft during the succeeding steps or after the vfo subchassis has been removed from the receiver.

- (4) Loosen the four green captive screws in the front mounting bracket of the subchassis, and loosen the green color-coded captive screw in the rear bracket.
- (5) Carefully remove the subchassis from the receiver; lift it straight up to disengage the coupler and then tilt it slightly to clear the receiver. The floating disk is held in place by a coating of grease; take steps to avoid its loss.

n. Replacement of Vfo Subchassis. To replace the vfo subchassis, proceed as follows:

- (1) If the vfo tuning shaft was disturbed while the subchassis was being removed from the receiver or if a new vfo is to be installed, synchronize the shaft as described in paragraph 120i.
- (2) If the position of the tuning shaft has not been changed, follow the removal procedure (*m* above) in reverse order.

o. Removal of Band-Switching Motor Power Supply (fig. 71). To remove the band-switching motor power supply, proceed as follows:

- (1) Remove the bottom dust cover of the receiver.
- (2) Disconnect plug P116 from J423.
- (3) Remove the two roundhead screws which hold the power supply to the main frame side panel, and remove the two similar screws which are located between the power supply and vfo.

(4) Lift the unit straight out of the receiver.

p. Replacement of Band-Switching Motor Power Supply. To replace the band-switching motor power supply, follow the removal procedure (*o* above) in reverse order.

q. Removal of Antenna Box (fig. 71). To remove the antenna box for troubleshooting or repair, proceed as follows:

- (1) Disconnect coaxial connector P209 from J109, P210 from J110, and P211 from J111.
- (2) Unsolder the leads from the winding of antenna relay K101 (fig. 72).
- (3) Remove the three screws that secure the antenna box to the back panel of the receiver.

r. Replacement of Antenna Box. To replace the antenna box, follow the removal procedure (*q* above) in reverse order.

s. Removal of Dial Lamps (fig. 69). To remove dial lamps I 201 and I 202, unscrew the cap which is mounted on the back of the dial front plate by turning it counterclockwise. After detaching the socket, remove the midget lamp from the holder in the dial plate.

t. Replacement of Dial Lamps. To replace the dial lamps, follow the removal procedure (*s* above) in reverse order.

u. Removal of Tuning Motor Brushes. To re-

move the brushes from motor B202, unseat the small spring clamps retaining the rubber gaskets located near the top of the motor. Remove the brushes by prying the spring holders out of the brush receptacles.

v. Replacement of Tuning Motor Brushes. To replace the tuning motor brushes, follow the removal procedure (*u* above) in reverse order.

111. Lubrication of Mechanical Tuning System

The only parts of the radio receiver that require lubrication are the mechanical gear train (including the tuning motor gear train, and slug racks) and the BFO PITCH control-shaft bearing. The receiver is lubricated initially at the factory and should be lubricated thereafter every 6 months under normal operating conditions. The lubrication interval should be shortened only if need is indicated by inspection or if abnormal conditions or activities are encountered. When the equipment is operated in a hot, dry climate, it may be necessary to lubricate the porous bronze fittings about twice as often as indicated. It must be remembered that overlubrication can cause more harm than no lubrication. Check the condition of the mechanical tuning system each time that the receiver is withdrawn from the case or rack for servicing. Rotate the FREQ CHANGE control

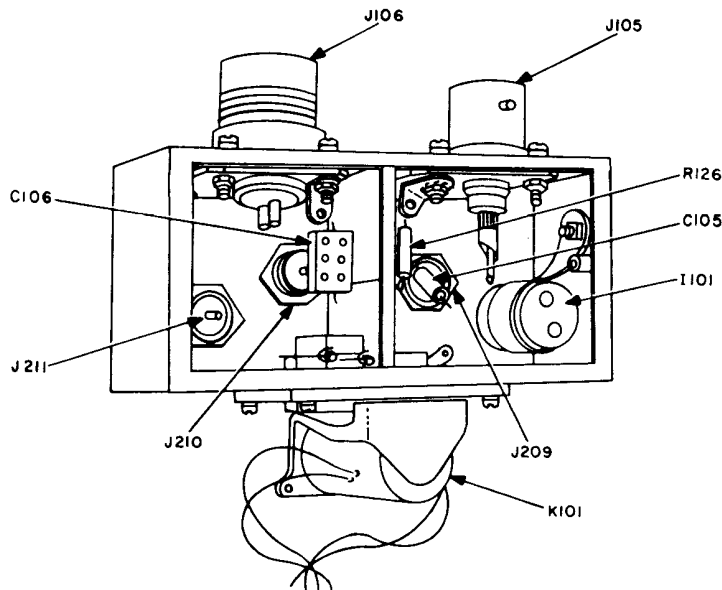
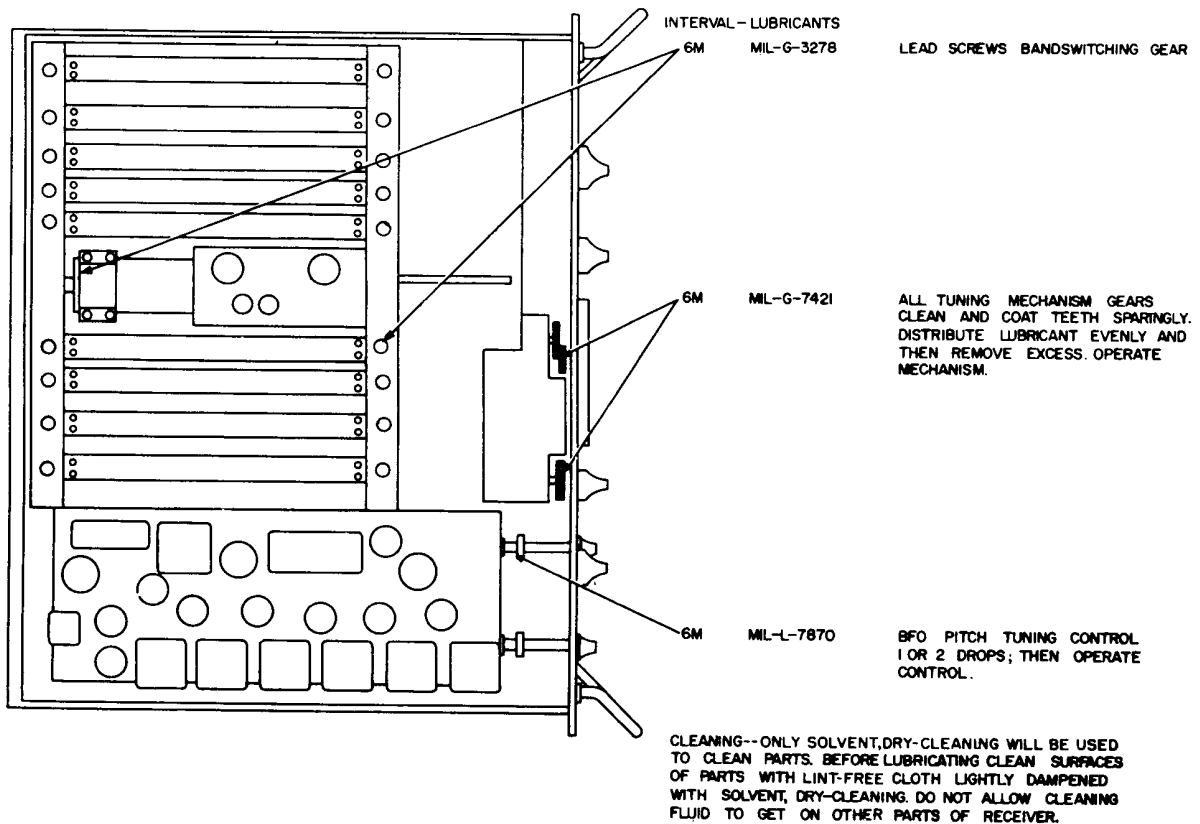

Figure 72. Antenna box, interior view.

TM 855-63

LUBRICANTS	INTERVAL
MIL-L-7870-LUBRICATING OIL GENERAL PURPOSE, LOW TEMPERATURE	6M-6 MONTHS
MIL-G-7421-GREASE	



TM 855-85

Figure 73. Lubrication of tuning mechanism, slug racks, and band-switching motor.

manually through its range and check for ease of operation. Check for lack of lubrication on gears, bearings, and lead screws; inspect for gritty grease and oil. Operate the BFO PITCH control; if operation is rough or uneven, check the lubrication of the control-shaft bearing. Operate the MOTOR TUNE control. Check for excessively noisy operation and proper operation of the tuning and band-switching motors. Carefully listen for changes in motor speed, because binding of the gear train or bearings will appear as motor drag.

Caution: Do not attempt to lubricate the sealed oscillator (vfo), regardless of possible noisy operation of the unit during tuning. Unstable operation of the receiver may result.

a. *Cleaning Before Lubrication.* Remove the rf subchassis in accordance with the instructions contained in paragraph 110e. Use a thin, long-handled brush having medium bristles dipped in Solvent, Dry Cleaning (SD). Remove dirt, oil, and grease from the gears, bearings, and lead screws. Rotate the **FREQ CHANGE** control to reach all the gear teeth. After dipping the brush in solvent (SD), remove the excess fluid to prevent it from dripping on connecting cables, wiring, or other electrical parts. Before proceeding with lubrication, use a clean, dry, lint-free cloth to wipe all parts.

b. *Detailed Lubrication Instructions.* Lubricate the gear train and lead screws as indicated in figure 73. To oil the bearings, dip a length of wire into the oil to collect a small drop at the end, and

transfer the oil to the bearing by touching the end of the wire to the edge of the bearings. Do not use too much oil. A standard grease gun and a thin long-handled brush should be used to apply the grease.

112. Parts Lubricated by Manufacturer

Prior to delivery of Radio Receiver R-389/URR, the following parts are lubricated by the manufacturer:

- a. Gears and lead screws—Grease, Aircraft and

Instruments (GL), MIL-G-3278 or Alpha-Moly G.

- b. Bearings—Oil, General Purpose, Low Temperature, Lubricating (OGP), MIL-L-7870.

113. Refinishing

Instructions for touchup painting are given in paragraph 41b, and instructions for refinishing badly marred panels or exterior cabinets are contained in TM 9-2851, Painting Instructions for Field Use.

Section III. ALINEMENT AND ADJUSTMENT PROCEDURES

114. Test Equipment and Tools Required for Alinement and Adjustment

- a. *Signal Generator.* The signal generator must be an accurately calibrated instrument, such as Signal Generator TS-588A/U (TM 11-5018), capable of producing rf signals within a frequency range of 15 to 1,500 kc. The attenuator must be capable of varying the output of the signal generator over a range of approximately 1 microvolt to 1 volt.

- b. *Output Meter.* Output Meter TS-585/U (TM 11-5017) or equivalent should be used when measuring the rf sensitivity. A vacuum-tube voltmeter, such as Electronic Multimeter TS-505/U (TM 11-5511), is also required.

- c. *Voltohmeter.* A voltohmmeter is required for voltage and resistance checks. Multimeter TS-352/U (TM 11-5527) is suitable for this purpose.

- d. *Vtvm.* A vacuum-tube voltmeter that has a .01- to .1-volt ac range, such as Electronic Multimeter ME-6A/U (TM 11-5549), is required for performing the regulated-voltage hum adjustment.

- e. *Variable Autotransformer.* A variable autotransformer, such as Transformer CN-16/U, is required for performing the regulated-voltage hum adjustment.

- f. *Tools.* A bakelite alinement tool is required for adjusting trimmer capacitors. Any metal screwdriver of suitable size may be used for adjusting the transformer cores. The wrench and the screwdriver supplied with the receiver are required for adjustments during synchronization of the tuning shafts.

Notc. Before alining allow the receiver to warm up for at least 1 hour.

115. Adjustment of Band-Switching Motor Control Switch

Synchronize the band-switching motor control switch as follows:

- a. Manually tune the receiver to 27 kc.
- b. Loosen the clamp screw of the slider on section A (fig. 74).
- c. Adjust the slider so that it rests between the segments of bands A and B. Tighten the clamp screw. Check to see that band switching takes place between 26 and 28 kc for rotation in either direction of the **FREQ CHANGE** knob.
- d. Tune the receiver to 865 kc.
- e. Loosen the clamp screw of the slider on section B (fig. 74).
- f. Adjust the slider so that it rests between the segments of bands F and G. Tighten the clamp screw. Check to see that the band switching takes place between 860 and 870 kc for rotation in either direction of the **FREQ CHANGE** knob.
- g. Make sure that open-circuit conditions exist between the sliders and associated band segments by measuring with an ohmmeter.

116. Adjustment of the **FREQ CHANGE** Slip Clutch (fig. 45)

Proper adjustment of the **FREQ CHANGE** slip clutch is done in the following manner:

- a. Operate the tuning motor until the 52-turn stop engages at either the high or low extremity of the tuning system.
- b. Tighten the slip-clutch screws until the **FREQ CHANGE** knob turns the frequency counter. Proper adjustment occurs when the knob slips as the **DIAL LOCK** is tightened, and normal manual turning is possible when the **DIAL LOCK** is disengaged.

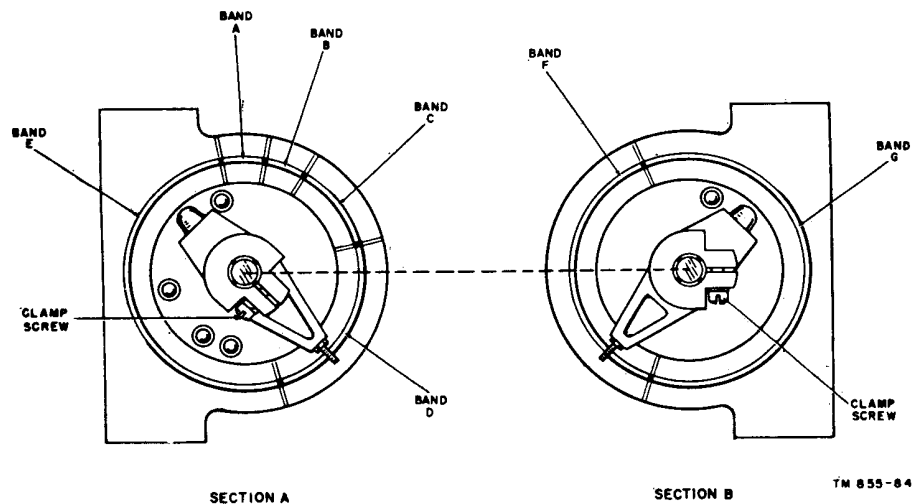

Figure 74. Band-switching motor control switch, showing segments and sliders.

117. Adjustment of the Disk Clutch Assembly (figs. 75 and 76)

The disk clutch assembly is adjusted in the following manner:

- a. Loosen the clutch-adjusting nuts (fig. 75).
- b. Move the clutch arm mounting post to the position that permits the gear train to turn when the MOTOR TUNE switch is operated. The clutch arm mounting post is positioned correctly when there is the least binding as the FREQ CHANGE knob is turned manually and when there is no excessive slippage as the tuning motor is used.

118. Regulated-Voltage Hum Adjustment

If objectionable hum is noted in the output of the receiver, adjust the regulated voltage for minimum hum as follows:

- a. Be sure that switch S801 is in the 115-volt position (fig. 71).
- b. Connect Power Cable Assembly CX-1358/U between the receiver and a variable autotransformer, such as Transformer CN-16/U.
- c. Connect Multimeter TS-352/U, set at 100- to 200-volt ac range, across the output of the autotransformer.
- d. Connect Electronic Multimeter ME-6A/U, set at .01 to .1-volt ac range, between B+ 180 V DC jack J601 (fig. 60) and ground.

Warning: Avoid contact with the B+ 180 V DC jack when the receiver is turned on; the high voltage present at this jack is dangerous.

e. Be sure that the receiver is grounded; then connect the autotransformer to 115-volt, 60-cycle source.

f. Check to see that switch S801 on Power Supply PP-621/URR is set at the 115V position; then turn on the receiver and allow it to warm up.

g. Adjust the autotransformer for an accurate 115-volt line-voltage indication on Electronic Multimeter ME-6A/U.

h. Insert the screw driver in the slot of HUM BAL control R614 (fig. 81), accessible through the right side plate of the main frame, and adjust for minimum indication on Electronic Multimeter ME-6A/U.

119. Checking Mechanical Synchronization

Before starting to align the receiver, check the synchronization of the dial and tuning slug racks as described in a through f below. Refer to figure 77 for the locations of the various slug racks.

a. Tune the FREQ CHANGE control to 14.0 kc on the dial.

b. Carefully measure from the top of the vfo output circuits slug rack to the top of the lead-screw bearing retainer bar (fig. 78). This distance should be exactly 1.656 inches at both ends of the slug rack.

c. Measure from the top of the injection mixer circuits slug rack to the top of the lead-screw retainer bar. This distance should be exactly .656 inch.

d. Tune the FREQ CHANGE control to 28.8 kc on the dial. Check to see that the band A slug

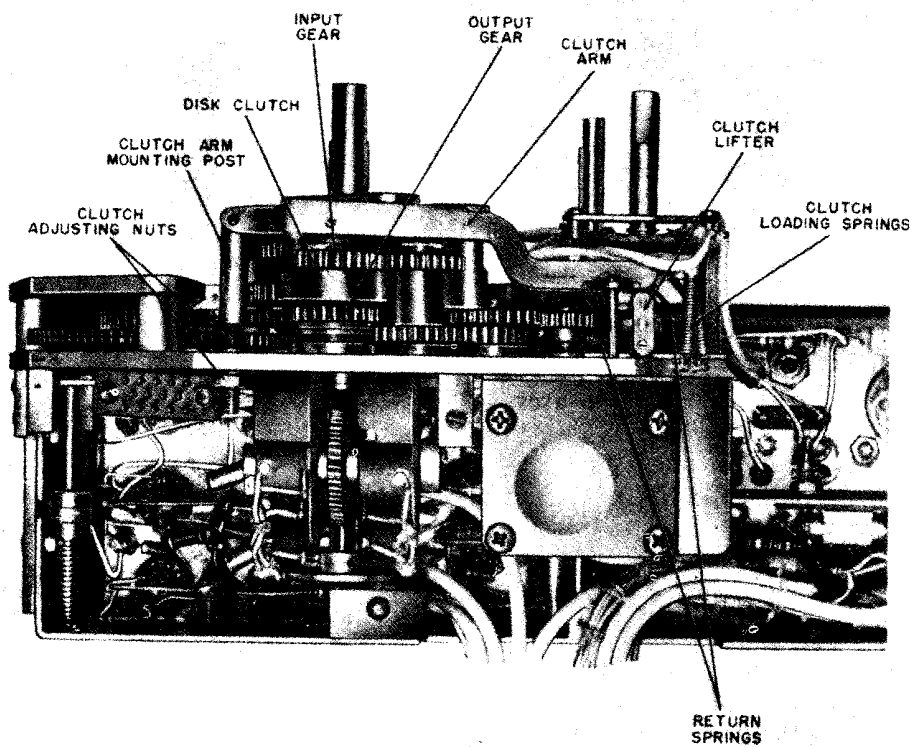

TM 855-86

Figure 75. Disk clutch assembly, mounted.

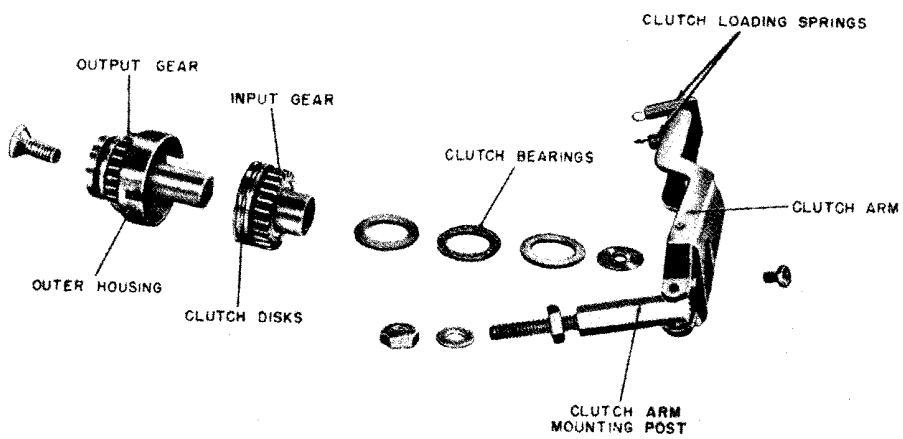

TM 855-87

Figure 76. Disk clutch assembly, exploded view.

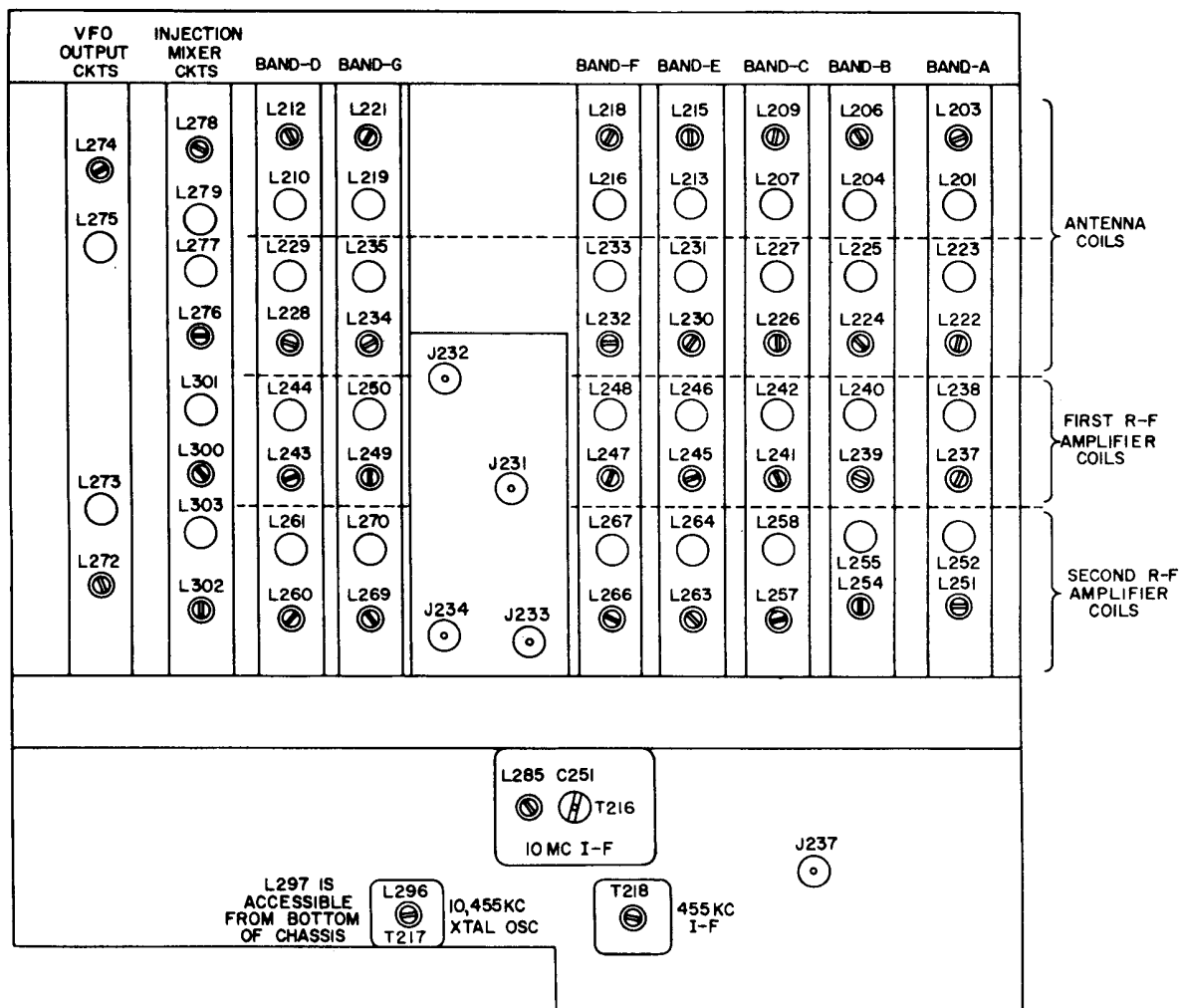

TM 855-88

Figure 77. Location of rf alignment adjustments.

rack is at the extreme top of its travel on its two lead screws. To do this, turn the **FREQ CHANGE** control a few turns in each direction from 28.8 kc. As the control is turned in each direction, the band A slug rack should start to go downward.

e. Check the dial settings at which the remainder of the slug racks should be at the top of their travel as shown in (1) through (6) below.

- (1) Check band B slug rack at 57.8 kc.
- (2) Check band C slug rack at 123.8 kc.
- (3) Check band F slug rack at 219.0 kc.
- (4) Check band D slug rack at 253.0 kc.
- (5) Check band E slug rack at 521.0 kc.
- (6) Check band G slug rack at 545.0 kc.

f. If one or more of the slug racks are not at the positions given in *a* through *e* above, follow the instructions in paragraph 120 for synchronizing the tuning system.

120. Synchronization of Tuning System

To perform the synchronizing operations given in *a* through *h* below, first remove the rf subchassis from the main frame (par. 110e). To check that any slug rack is at the top of its travel, pass a stiff wire through the holes provided in the front and rear chassis plates, through the larger hole in the slug rack slide that travels on the lead screw, and through the small hole in the shaft of the lead screw (fig. 78).

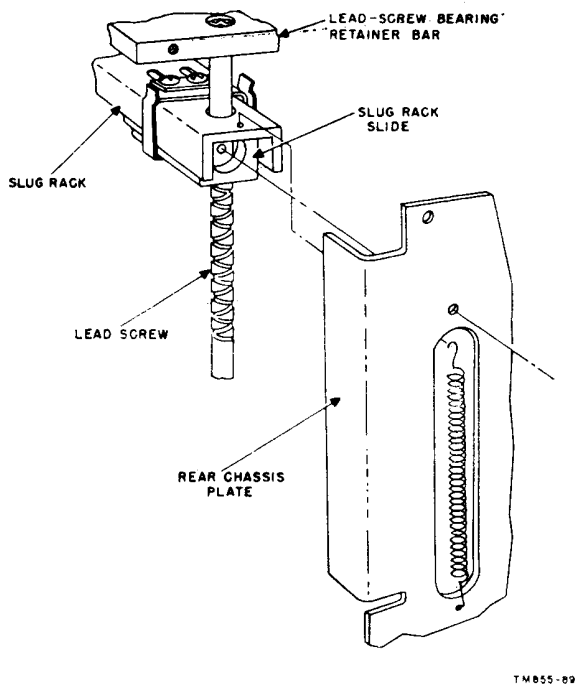

Figure 78. Section of tuning slug rack.

a. Vfo and Mixer Circuits.

- (1) Set the tuning indicator to 14.0 kc.
- (2) Loosen the clamps on the four lead screws for the injection mixer circuits and the vfo output circuits. Remove the locking keys, clamps, and gears. Refer to figure 77 for the location of the proper slug racks. Figure 79 identifies the parts to be loosened or removed.
- (3) With a screwdriver, turn the two lead screws that drive the vfo output slug rack until the rack is 1.656 inches down from the top of the lead-screw retainer bar (fig. 78). Measure the distance carefully at each end of the slug rack.
- (4) Replace the vfo slug rack gears and clamps, insert the locking keys, and tighten the clamps.
- (5) Set the rack for the injection mixer in the same manner as described in (3) above; carefully measure .656 inch down from the retainer bar.
- (6) Replace the injection mixer slug rack gears and clamps, insert the locking keys, and tighten the clamps.

b. Band A Slug Rack.

- (1) Set the frequency indicator dial at 28.8 kc.
- (2) Loosen the clamps and remove the two lead-screw gears for band A slug rack (fig. 77).
- (3) Manually turn the two lead screws until the rack is at the top of its travel; use the alining-wire method described at the beginning of this paragraph as a check.
- (4) Replace the gears and locking keys and tighten the clamps for the front and rear lead screws while the alining wires are still in place.
- (5) Remove the alining wires from the lead screws.

c. Band B Slug Rack.

- (1) Set the frequency indicator dial at 57.8 kc.
- (2) Perform the procedure given in *b*(2) through (5) above for the band B slug rack.

d. Band C Slug Rack.

- (1) Set the frequency indicator dial at 123.8 kc.
- (2) Perform the procedure given in *b*(2) through (5) above for the band C slug rack.

e. Band D Slug Racks.

- (1) Set the frequency indicator dial at 253.0 kc.

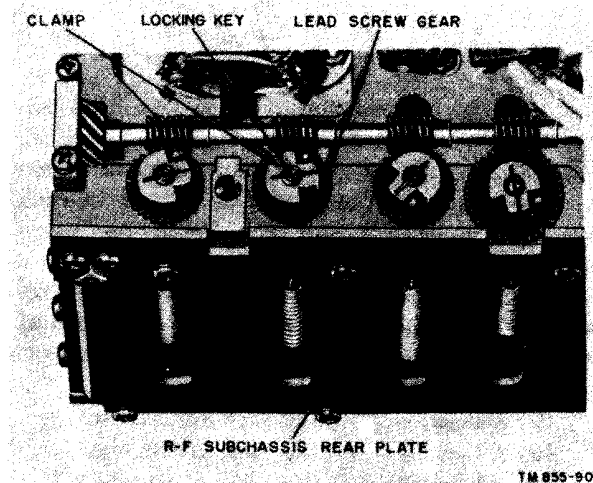

Figure 79. Sectional view of slug-rack lead screw drive assembly.

- (2) Perform the procedure given in *b*(2) through (5) above for the band D slug rack.

f. Band E Slug Rack.

- (1) Set the frequency indicator dial at 521.0 kc on the low range.
- (2) Perform the procedure given in *b*(2) through (5) above for the band E slug rack.

g. Band F Slug Rack.

- (1) Set the frequency indicator dial at 219.0 kc.
- (2) Perform the procedure given in *b*(2) through (5) above for the band F slug rack.

h. Band G Slug Rack.

- (1) Set the frequency indicator dial at 545.0 kc on the low range.
- (2) Perform the procedure given in *b*(2) through (5) above for the band G slug rack.

i. Variable-Frequency Oscillator. Before performing the operations described in (1) through (5) below, refer to the caution at the beginning of paragraph 110. To synchronize the vfo, proceed as follows:

- (1) Remove the vfo subchassis without unplugging the connecting cables (par. 110*m*).
- (2) Turn the **FREQ CHANGE** knob to obtain the lowest frequency reading as noted under the caution in paragraph 110.
- (3) Manually turn the Oldham coupler flange on the vfo shaft counterclockwise until the 52-turn stop mechanism prevents further rotation.
- (4) Replace the vfo chassis (par. 110*n*); be careful that the two parts of the Oldham coupler fit together properly. It may be necessary to rock the **FREQ CHANGE** control slightly to engage them.
- (5) After the vfo chassis is replaced, the frequency indication, when the **FREQ CHANGE** control is rotated to the low stop, should be the same as that previously noted.
- (6) If the lowest frequency reading on the frequency counter is not known, synchronize the vfo as follows:

- (*a*) Remove the vfo subchassis without unplugging the connecting cables (par. 110*m*).
- (*b*) Set the **FREQ CHANGE** control for a dial reading of exactly 15 kc.
- (*c*) Turn the Oldham coupler flange counterclockwise until the 52-turn stop prevents further rotation.
- (*d*) Insert a length of wire between V702 and its shield. Connect the other end of the wire to the antenna input of another receiver, such as another Radio Receiver R-389/URR. Tune the second receiver to exactly 470 kc; with its bfo on and its bfo pitch control set at zero.
- (*e*) Turn the vfo shaft clockwise until the output of the vfo is zero beat in the receiver.
- (*f*) Replace the vfo subchassis (par. 110*n*). It may be necessary to rock the **FREQ CHANGE** control slightly to permit the parts of the Oldham coupler to fit together properly.

121. Alinement of 455-kc If. Stages

a. Turn on Signal Generator TS-588A/U and allow it to warm up to its stabilized condition. Connect it between the control grid (pin 1) of second mixer tube V205 and ground.

b. For an output meter, connect a vtvm (vacuum tube voltmeter) (such as Electronic Multimeter TS-505/U) between **DIODE LOAD** terminal 15 of the rear terminal strip (fig. 7) and ground. Set the function switch of the vtvm for negative dc polarity at terminal 15.

c. Set the **IF. BANDWIDTH** switch to the .1 KC position, **RF GAIN** control to 10, and **BFO** switch to **OFF**. Remove vacuum tube V210 from its socket to disable the 10,455-kc crystal oscillator during alinement of the if. stages. Turn the **FUNCTION** switch to **MGC** and allow the receiver to warm up for several minutes.

d. Tune the signal generator to 455 kc (unmodulated); then adjust its frequency control for peak indication on the vtvm. To obtain a peak indication, it may be necessary to set the attenuation of the signal generator for high amplitude output signal (3 volts). If an indication on the vtvm is obtained, proceed with *e* below. If an indication is not obtained, perform the procedure

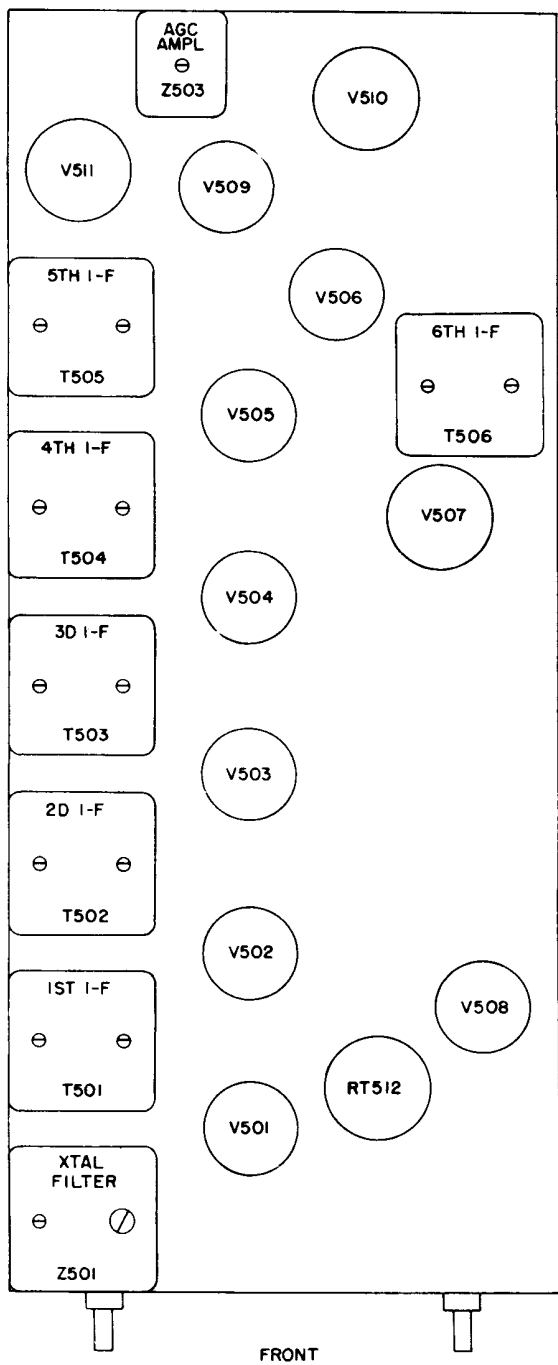

TM 855-91

Figure 80. If. subchassis, location of tubes and trimmers.

outlined in (1) below and, if necessary, (2) below, to secure approximate alinement before proceeding with *e* below.

- (1) With the signal generator tuned to 455 kc and set for full output, turn the re-

ceiver IF. BANDWIDTH switch to the 8 KC position. If the output indication is not yet obtained, proceed with (2) below. If the output is obtained, adjust the cores of transformers T506 through T501 (fig. 80) and T218 (fig. 77), in that order, for peak indication on the vtvm. Set the IF. BANDWIDTH switch at the next lower position and repeat the adjustment of the transformer cores for peak output. Repeat this procedure for each setting of the IF. BANDWIDTH switch until peak output is obtained at the .1 KC position of the switch; then proceed with (e) below.

Note. The frequency of the tuned circuits will decrease as the slugs are screwed farther into the coils, and will increase as the slugs are withdrawn.

- (2) It should be necessary to perform the procedure outlined in (a) through (e) below only when the transformer cores have been displaced greatly from their normal positions within the coils. Set the IF. BANDWIDTH switch to the 2 KC position, and proceed as follows:
 - (a) Tune the signal generator to 455 kc and set it for maximum output. Remove sixth if. amplifier tube V506 (fig. 80) and wrap a thin wire around pin 1 (control grid). Replace the tube and connect the other end of the wire to the signal generator output.
 - (b) Adjust the cores of transformer T506 for peak indication on the vtvm.
 - (c) Connect the signal generator output to fifth if. amplifier V505 in the same manner as described in (a) above, and adjust the cores of transformer T505 for maximum output.
 - (d) Repeat the above procedure for each remaining set of if. tubes and transformers in the following order: V504 and T504, V503 and T503, V502 and T502, V501 and T501, and V205 and T218.
 - (e) Set the IF. BANDWIDTH switch to .1 KC position and proceed as outlined in *e* below.

e. Connect the signal generator output to the control grid (pin 1) of V205 and set it to 455 kc. While adjusting the attenuator of the signal gen-

erator to maintain an output of approximately 6 volts, as indicated on the vtvm, carefully tune the signal generator to the exact frequency required to obtain a peak output indication on the vtvm. Do not disturb this frequency setting while carrying out the procedures outlined in *f*, *g*, and *h* below. Check the setting repeatedly during these steps to be sure it has not been changed.

f. Set the IF. BANDWIDTH switch to the 2 KC position.

g. Adjust the cores of transformers T506, T505, T504, T503, T502, and T218, in that order, for peak output indication, while continuously adjusting the attenuator of the signal generator to maintain an indication of approximately 6 volts on the vtvm. Repeat these adjustments until no further increase in output is noticeable.

h. Change the setting of the IF. BANDWIDTH switch to the 8 KC position, and adjust the cores of transformer T501 for maximum output. Repeat the adjustment of the cores until no further increase in output can be produced.

i. Return the IF. BANDWIDTH switch to the .1 KC position.

j. Adjust the output of the signal generator for an indication of 6 volts on the vtvm. While detuning the signal generator in one direction from the 455-ke point, adjust the attenuator to multiply the output by 1,000. Continue to detune the signal generator until the vtvm indicates 6 volts.

k. Adjust the phasing capacitor in crystal filter Z501 for a minimum indication on the vtvm. Mark the location of the capacitor slot.

l. Tune the signal generator to the other side of 455 ke until the vtvm again indicates 6 volts.

m. Again adjust the phasing capacitor in Z501 for a minimum indication on the vtvm and mark the position of the slot. Set the capacitor halfway between the two marks. To avoid possible incorrect indications caused by passing through minimum or maximum capacitance, note that the two settings for minimum output must be less than 45° apart.

n. With the IF. BANDWIDTH switch in the .1 KC position, tune the signal generator to obtain peak output. Set the IF. BANDWIDTH switch to the 1 KC position. Adjust the core of the *tuning coil* in crystal filter Z501, until the frequency indication required for obtaining peak output with the IF. BANDWIDTH switch in 1 KC position corresponds exactly with the frequency indication required for peak output with the IF.

BANDWIDTH switch in the .1 KC position. Retune the signal generator, and alternately change positions of the IF. BANDWIDTH switch as required to complete this adjustment.

o. Set the IF. BANDWIDTH switch to the .1 KC position, and tune the signal generator for maximum output as described in *e* above. Do not disturb this frequency setting during the adjustment of the agc tuning circuit as instructed in *p* through *r* below.

p. Disconnect the vtvm lead from terminal 15 of the rear terminal strip, and connect it to terminal 4 of the rear terminal strip (fig. 7).

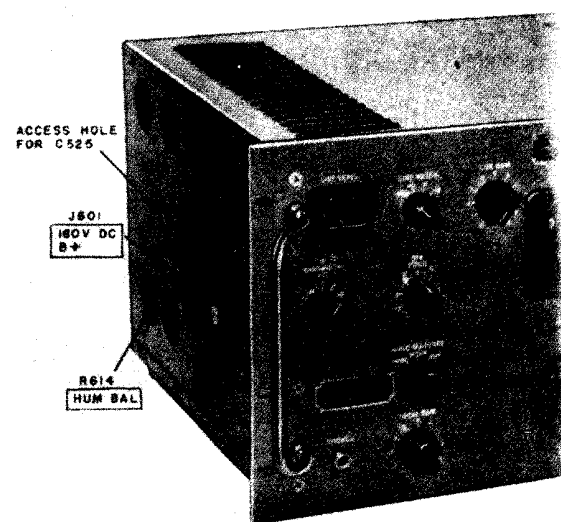

TM855-102

Figure 81. Components behind left side of main frame.

q. Set the FUNCTION switch to AGC, and the IF. BANDWIDTH switch to the 2 KC position. Insert vacuum tube V210 into its socket.

r. Adjust the core of Z503 for a maximum voltage indication on the vtvm, while adjusting the attenuator of the signal generator to maintain a peak indication of approximately 2 volts. When this adjustment is completed, disconnect the vtvm.

122. Alinement of Rf Subchassis

a. General. The chart in *b* below gives the steps for alining the vfo, the injection mixer, and the output coupler circuits. Connect Electronic Multimeter ME-6A/U between test jack J237 and ground. Set the meter to measure rf voltage. Follow the steps in the order given. Figure 77 shows the location of the parts to be adjusted.

b. Alinement of Vfo, Injection Mixers, and Output Coupler.

Circuit	Step	Set FREQ RANGE at (kc)	Tune revr to kc	Adjust	Procedure
Vfo output circuits	1	15-500	15	L274	For steps 1 through 4, adjust for maximum indication on vtvm. Repeat these steps until no further increase in vtvm indication is obtained.
	2	500-1500	500	L272	
	3	15-500	500	L275	
	4	500-1500	1,500	L273	
Injection mixers	5	15-500	15		Position L300 and L302 slugs approximately ¼ inch above slug rack. For steps 6 through 9, adjust for maximum indication on vtvm. Repeat these steps until no further increase in vtvm indication is obtained.
	6	15-500	15	L301	
	7	500-1500	500	L303	
	8	500-1500	1,500	L302	
Output coupler	9	15-500	500	L300	Position L276 and L278 slugs approximately ¼ inch above slug rack. For steps 11 through 14, adjust for maximum indication on vtvm. Repeat these steps until no further increase in vtvm indication is obtained.
	10	15-500	15		
	11	15-500	15	L277	
	12	500-1500	500	L279	
	13	500-1500	1,500	L278	
	14	15-1500	500	L276	

Note. During the remaining procedures in this paragraph, set the IF BANDWIDTH switch to the bandwidth indicated on the RF BANDWIDTH indicator whenever the frequency of the receiver is changed.

c. First Mixer Output Transformer T216 (fig. 87).

- (1) Set the FUNCTION switch to MGC, RF GAIN control to maximum, FREQ RANGE switch to 500-1500 KC, and BFO switch to OFF. Tune the receiver to 1500 kc.
- (2) Connect a vtvm to measure the dc voltage between DIODE LOAD terminal 15 or 16 and ground on the rear terminal strip (fig. 7). The meter should be set to measure approximately 5 volts. Set the function switch of the meter to measure negative polarity at terminal 15 or 16.
- (3) Set the signal generator to approximately 1500 kc, and connect its output to the ANTENNA BALANCED 125 OHM input jack.
- (4) Tune the signal generator for peak indication on the vtvm, and adjust the output attenuator of the signal generator to keep the vtvm indication below 5 volts.

- (5) Alternately adjust primary trimmer capacitor C251 and the slug of secondary coil L285 to obtain a peak indication on the vtvm.

Caution: There is high voltage on the trimmer capacitor. Use a nonmetallic screw driver for adjusting this capacitor.

d. Second Mixer Output, Transformer T218 (fig. 77). Follow the procedure described in *c* above; adjust the slug of transformer T218 (instead of T216) to obtain a peak indication of vtvm.

e. 10,455-kc Crystal Oscillator, Transformer T217 (fig. 77).

- (1) Connect a vtvm to measure the rf voltage at test jack J237.
- (2) Remove the clamping bar (fig. 71) to reach the slug of secondary coil L297, and adjust for a peak indication on the vtvm.
- (3) Disconnect the vtvm from J237. Connect and adjust the vtvm as described in *b*(2) above.
- (4) Set the FUNCTION switch to MGC, the RF GAIN control to 10, and the FREQ RANGE switch to 500-1500 KC. Tune the receiver for a dial reading of 1,500 kc.

- (5) Set the signal generator to approximately 1,500 kc, and connect the generator output to the receiver ANTENNA BALANCED 125 OHM input jack.
- (6) Tune the signal generator for peak indication on the vtvm, and adjust the output attenuator of the signal generator to keep the vtvm indication below 5 volts.
- (7) Adjust the slug of primary coil L296 to obtain a peak indication on the vtvm.

f. Rf Stages.

- (1) Set the FUNCTION switch to MGC and the RF GAIN control to 10.
- (2) Leave the vtvm connected as indicated in *d* above.
- (3) If preliminary adjustments are unnecessary, connect the signal generator output to the receiver ANTENNA BALANCED 125 OHM input jack.

Note. Refer to the appropriate technical manual for the signal generator for the proper method of matching the impedance of the signal generator and receiver.

- (4) If preliminary adjustments are necessary because of extreme misalignment, connect the signal generator through a .01-microfarad (μf) capacitor in series with a 10,000-ohm resistor, to the jack points listed in column 5 of the chart ((8) below) in the order given, instead of connecting it to the antenna input terminals. Proceed with alinement as directed in (5) through (8) below. After completing the preliminary procedure, connect the signal generator to the antenna input terminals; then repeat the alinement; make all the adjustments in the order listed.
- (5) With the FREQ CHANGE control, set the frequency indicator dial to the settings listed in the first column of the chart and set the FREQ RANGE switch to the position indicated in the second column.
- (6) After setting the FREQ CHANGE control and the FREQ RANGE switch for a group of adjustments, tune the signal generator to the frequency listed in the third column. To obtain the exact required frequency, tune the signal generator for a peak indication on the vtvm.

- (7) During the alinement procedure, change the setting of the signal-generator attenuator as required to maintain an output indication of less than 5 volts.
- (8) Proceed with the rf alinement by performing the adjustments in the order listed in the chart below. Refer to figure 77 for the location of tuning slugs. Refer to figure 53 for the locations of the test jacks. Jack J105 is the ANTENNA UNBALANCED jack on the rear panel.

Note. The settings of the FREQ CHANGE control given in the first column represent the limits of the bands. When tuning from the low limit to the high limit in any one band, be sure that the band-switching motor does not cycle into the next higher band. For example, when tuning from 15 kc to 26 kc (band A), any overtravel past 26 kc will cause the band-switching motor to switch to band B. Should this happen, tune the FREQ CHANGE control low enough to restore the band-switching mechanism to band A.

FREQ CHANGE control setting	FREQ RANGE switch position (KC)	Signal generator frequency (tune for peak output) in kc	Adjust slugs for peak output	Signal generator connection (preliminary alinement only)
15-----	15-500---	15	L251 L237 L222 L203	J234 J232 J231 J235
26-----	15-500---	26	L252 L238 L223 L201	J234 J232 J231 J105
28-----	15-500---	28	L254 L239 L224 L206	J234 J232 J231 J105
54-----	15-500---	54	L255 L240 L225 L204	J234 J232 J231 J105
56-----	15-500---	56	L257 L241 L226 L209	J234 J232 J231 J105
115-----	15-500---	115	L258 L242 L227 L207	J234 J232 J231 J105
120-----	15-500---	120	L260 L248 L228 L212	J234 J232 J231 J105

FREQ CHANGE control setting	FREQ RANGE switch position (KC)	Signal generator frequency (tune for peak output) in kc	Adjust slugs for peak output	Signal generator connection (preliminary alignment only)
240-----	15-500---	240	L261 L244 L229 L210	J234 J232 J231 J105
245-----	15-500---	245	L263 L245 L230 L215	J234 J232 J231 J105
500-----	15-500---	500	L264 L246 L231 L213	J234 J232 J231 J105
500-----	500-1500.	500	L266 L247 L232 L218	J234 J232 J231 J105
860-----	500-1500.	860	L267 L248 L233 L216	J234 J232 J231 J105
870-----	500-1500.	870	L269 L249 L234 L221	J234 J232 J231 J105
1500-----	500-1500.	1500	L270 L250 L235 L219	J234 J232 J231 J105

123. Adjustment of Potentiometer R260

(fig. 49)

Set the FUNCTION switch to MGC. Connect the vtvm between one of the DIODE LOAD connections on the rear terminal strip and ground. Apply a 10-mc signal between jack J237 and ground. Adjust the RF GAIN control to keep the indication on the vtvm below 10 volts. Adjust R260 for minimum indication on the vtvm.

124. Adjustment of GAIN ADJ Potentiometer R562

a. Disconnect coaxial connectors P225 and P226 from J525 and J526, located on the if. sub-chassis (fig. 70).

b. Connect Signal Generator TS-588A/U or equivalent between J525 and the receiver ground (chassis). Turn on the signal generator and tune

it to 455 kc. Adjust the attenuator for an output of 150 μ v.

c. Connect a vtvm, such as Electronic Multi-meter TS-505/U, between DIODE LOAD terminal 15 on the rear terminal strip of the receiver and the receiver ground (fig. 7). Set the function switch of the meter for measuring -7 volts dc.

d. Turn the receiver FUNCTION switch to MGC and the RF GAIN control to 10. Adjust GAIN ADJ potentiometer R562 (fig. 55) for an indication of -7 volts on the vtvm. Reconnect P225 and P226 after completing the adjustment.

125. Adjustment of CARR-METER ADJ Potentiometer R537

The CARRIER LEVEL meter is zero-adjusted with the CARR-METER ADJ control R537 as follows: Set the FUNCTION switch at AGC and rotate the RF GAIN control to its extreme counterclockwise position. Adjust R537 (fig. 55) for an indication of 0 on the CARRIER LEVEL meter.

126. Adjustment of Neutralizing Capacitor C525

Adjust capacitor C525 after alinement of tuning circuits has been completed, or at any time when required to obtain minimum bfo signal at IF. OUTPUT 50 OHM jack J104.

a. Connect an ac vtvm such as Electronic Multimeter ME-6U from jack J104 to ground.

b. Remove Plug P225 (fig. 70) from jack J525. Ground the center terminal of J525. Use the shortest possible length of wire.

c. Turn IF. BANDWIDTH switch to 2 KC, RF GAIN control fully clockwise, BFO PITCH control to 0, BFO switch to ON, and the FUNCTION switch to AGC.

d. Insert a screwdriver that has an insulated shank through the hole in the left side of the main frame and engage trimmer capacitor C525 (figs. 56 and 81). Turn the trimmer capacitor to obtain minimum reading on the ac vtvm.

Caution: The screwdriver for adjusting C525 must be insulated to prevent short-circuiting bare wires in the if. chassis. A metal screwdriver that has a length of spaghetti tubing covering the shank is satisfactory.

e. Remove the ground wire from jack J525, replace plug P225, and remove the ac vtvm from IF. OUTPUT 50 OHM jack J104.

127. Calibration of Bfo

Calibrate the bfo whenever the front panel or the if. subchassis have been removed and replaced. Calibrate it as follows:

a. Set the IF. BANDWIDTH at the .1 KC position, turn the FUNCTION switch to AGC, and turn the RF GAIN control to 10.

b. Connect a headset or a loudspeaker to the receiver. Tune the FREQ CHANGE control until a strong, nonfading signal from an external source is received, as indicated on the CARRIER LEVEL meter and heard on the headset. Adjust the FREQ CHANGE control for maximum indication on the meter. If a satisfactory signal cannot be obtained use a signal generator, tuned to any frequency to which the receiver can be tuned.

c. Set the BFO switch at ON, and adjust the BFO PITCH control for zero beat; zero beat should occur at the 0 position of the control. If the condition is not obtained, loosen the clamp that secures the control shaft behind the front panel, and position the knob at 0; then tighten the clamp.

128. Measurement of Rf Sensitivity

In addition to the test equipment referred to in paragraph 114, a dummy antenna is required for this measurement. This consists of a 125-ohm nonreactive resistor for the balanced antenna input and a 250- $\mu\mu\text{f}$ capacitor for the unbalanced antenna input.

a. Setting of Front Panel Controls.

- (1) Set the IF. BANDWIDTH switch according to the following chart:

Band	Range kc	Set IF. BANDWIDTH to KC
A.....	15-27.....	1
B.....	27-55.....	2
C.....	55-117.....	4
D through G.....	117-1,500.....	8

- (2) Set the FUNCTION switch to MGC.
- (3) Set the RF GAIN control to maximum.
- (4) Set the BFO switch to OFF.
- (5) Set the LIMITER control to 0.
- (6) Set the AUDIO RESPONSE control to MEDIUM.

b. Preliminary Procedure for Measurement of Am Sensitivity.

- (1) Connect Signal Generator TS-588A/U output in series with dummy antenna (125-ohm resistor) to the balanced antenna jack.
- (2) Adjust Output Meter TS-585/U controls for 600 ohms and connect it to LOCAL AUDIO terminals 6 and 7 on the rear panel of the receiver.
- (3) Set Electronic Multimeter TS-505/U for negative dc voltage and connect it between diode terminals 15 and 16, and ground on the rear panel.

c. Measuring Sensitivity. The sensitivity measurement should be made at both ends and in the middle of all bands. These frequencies (and bands) may be found in the table in paragraph 89.

- (1) Using the test conditions in *a* above, tune the receiver to the lowest frequency (15 kc), and adjust the signal generator output with no modulation for a vtvm reading of 7 volts. Adjust the signal generator frequency control to around 15 kc for a maximum vtvm indication and readjust the generator output for 7 volts. Note and record the reading on signal generator attenuator dials.
- (2) Adjust the receiver audio gain control for a reading of 1 milliwatt on the power output meter. Turn the signal generator modulation on (400 cycles at 30-percent modulation). Adjust the signal generator attenuator dials and the receiver's AUDIO GAIN for a reading of 10 milliwatts. Turn the modulation off and recheck for 1-milliwatt reading. Again turn the modulation on and check for 10 milliwatts. Repeat these checks until the proper 1 to 10 ratio is established.
- (3) Note and record the signal generator attenuator reading. This is the sensitivity figure of the receiver in microvolts.
- (4) Tune the receiver to the next higher frequency (midway between 15 and 27 kc) and repeat the steps in (1) through (3) above. Turn to 27 kc and repeat the procedure.
- (5) Use the same procedure ((1) through (4) above) to check the sensitivity on all bands up to 1,500 kc.

Section IV. FINAL TESTING

129. General

This section gives the final performance tests of the equipment. Repaired equipment meeting these performance tests will furnish uniformly satisfactory operation. Allow the receiver to warm up for a few minutes before making any measurements.

Warning: The voltages used are sufficiently high to endanger human life. Every precaution should be taken by personnel to minimize the danger of shock. The receiver chassis should be grounded during these tests.

130. Test Equipment Required

The test equipment required for final testing of Radio Receiver R-389/URR is listed *a* through *g* below.

- a.* Electronic Multimeter TS-505/U.
- b.* Spectrum Analyzer TS-723/U.
- c.* Signal Generator TS-588A/U.
- d.* Audio Oscillator TS-382A/U (TM-11-2684A).
- e.* Electron Tube Test Set TV-2/U (TM 11-2661).
- f.* Multimeter TS-352/U.
- g.* Electronic Multimeter ME-6A/U.

131. Preliminary Checks

Before testing the receiver, perform the following preliminary checks:

- a.* Check to see that all controls are operative and that they do not bind.
- b.* Measure B+ with an electronic multimeter (such as Electronic Multimeter TS-505/U) with the positive lead connected to B+ 180VDC jack J601 (fig. 81) and the negative lead connected to terminal 9 (marked GND) of rear terminal strip TB103 (fig. 7). The meter should indicate 180 volts ± 5 volts.
- c.* Check to see that all tubes and dial lights are lighted.
- d.* Check the antenna relay (par. 106*o*).
- e.* Check the bfo (par. 127).

132. If. Response

To check the if. response, proceed as follows:

- a.* Connect Electronic Multimeter TS-505/U between terminals 15 and 16 (DIODE LOAD) and

ground at rear terminal strip TB103 (fig. 7). Set the vtvm for negative voltage on the 10-volt scale.

- b.* Connect Signal Generator TS-588A/U to ANTENNA BALANCED 125 OHM receptacle J106. Tune the signal generator to a frequency of 400 kc. Adjust the attenuator for minimum output.

- c.* Set the IF. BANDWIDTH switch to the .1 KC position.

- d.* Set the FUNCTION switch to the MGC position.

- e.* Set the RF GAIN control to the 10 position.

- f.* Set the FREQ RANGE switch to the 15-500 KC position and turn the FREQ CHANGE knob until exactly 400 kc register on the frequency indicator.

- g.* Increase the signal generator output until an indication is obtained on the vtvm. Be sure that the output indication does not exceed 7 volts and tune the signal generator to maximum output indication.

- h.* Set the IF. BANDWIDTH switch to the 2 KC position.

- i.* Adjust the signal generator output attenuator, and if necessary, adjust the RF GAIN control to obtain a reference voltage indication of 7 volts on the vtvm.

- j.* Turn the FREQ CHANGE knob toward a lower frequency until the vtvm indicates 5 volts. The frequency indicator should read 399.2 kc.

- k.* Turn the FREQ CHANGE knob toward a higher frequency, passing through the 7-volt indication at 400 kc, until the vtvm again indicates 5 volts. The frequency indicator should read 400.8 kc. The voltages obtained in the procedures of *j* above and in this subparagraph represent 3-db points, and the difference in frequency-indicator dial readings should not exceed 2 kc.

- l.* Repeat the procedures of *j* and *k* above for a 3.5-volt indication on the vtvm. These readings represent 6-db points, and the difference in frequency-indicator dial readings should not exceed 2.5kc.

- m.* Repeat the procedures of *j*, *k*, and *l* above, with the IF. BANDWIDTH switch set to the 4 KC position. The difference in frequency-indicator dial readings for the 3-db points should not exceed 4 kc; the readings for the 6-db points should not exceed 4.5 kc.

n. Repeat the procedures of *j*, *k*, and *l* above, with the IF. BANDWIDTH switch set to the 8 KC position. The difference in frequency-indicator dial readings for the 3-db points should not exceed 9.2 kc; the readings for the 6-db points should not exceed 10.4 kc.

o. Compare the dial readings obtained above with the readings in the following table and the curve shown in figure 82.

IF BAND- WIDTH switch position (KC)	FREQ CHANGE setting (kc)	Voltage at 3 db below 7-volt reference	Voltage at 6 db below 7-volt reference	Reference voltage
2	398.8		3.5	
2	399.2	5.0		
2	400.0			7.0
2	400.8	5.0		
2	401.2		3.5	
4	397.9		3.5	
4	398.2	5.0		
4	400.0			7.0
4	401.8	5.0		
4	402.1		3.5	
8	394.8		3.5	
8	395.4	5.0		
8	400.0			7.0
8	404.6	5.0		
8	405.2		3.5	

133. Overall Audio Response

To check the overall audio response, proceed as follows:

a. Connect Signal Generator TS-588A/U to ANTENNA BALANCED 125 OHM receptacle J106. Tune the signal generator to a frequency of 1,000 kc. Adjust the attenuator for minimum output.

b. Connect the output cable of Audio Oscillator TS-382A/U to the EXTERNAL MOD. terminals on the rf signal generator. (The ground terminal of the audio oscillator must be connected to the left-hand EXTERNAL MOD. terminal.) Turn the MODULATION switch to EXT.

c. Connect Spectrum Analyzer TS-723/U, in parallel with a 600-ohm, 1-watt resistor, to LOCAL AUDIO terminals 6 and 7 of the rear terminal strip (fig. 7), in accordance with the instructions furnished with the analyzer.

d. Modulate the output of the rf signal generator at 30 percent.

e. Set the IF. BANDWIDTH switch to the 8 KC position.

f. Set the AUDIO RESPONSE switch to the WIDE position.

g. Set the LIMITER switch completely counterclockwise.

h. Turn the FUNCTION switch to the AGC position.

i. Set the FREQ RANGE switch to the 500-1500 KC position and tune the FREQ CHANGE knob to the frequency of the signal generator (1,000 kc).

j. Set the audio oscillator frequency at 1,000 cycles.

k. Adjust the LOCAL AUDIO control for convenient db reference level.

l. Note the db reading on the spectrum analyzer at 10-cycle intervals, from 30 to 100 cycles; at 100 cycle intervals, from 100 to 1,000 cycles; and at 1,000 cycle intervals, from 1,000 to 10,000 cycles.

m. Compare the readings obtained with those on the chart in figure 83.

n. Repeat the procedure of *l* through *m* above for the MEDIUM position of the AUDIO RESPONSE switch.

o. Repeat the procedure for the SHARP position of the AUDIO RESPONSE switch. Note the db readings at 100-cycle intervals from 600 to 1,000 cycles and compare them with the readings on the chart in figure 83.

p. Connect the spectrum analyzer in parallel with a 600-ohm resistor to LINE AUDIO terminals 11 and 14 of rear terminal strip (fig. 7), and repeat the procedures above, except to adjust the LINE AUDIO control for the db reference level used in the procedure of *k* above.

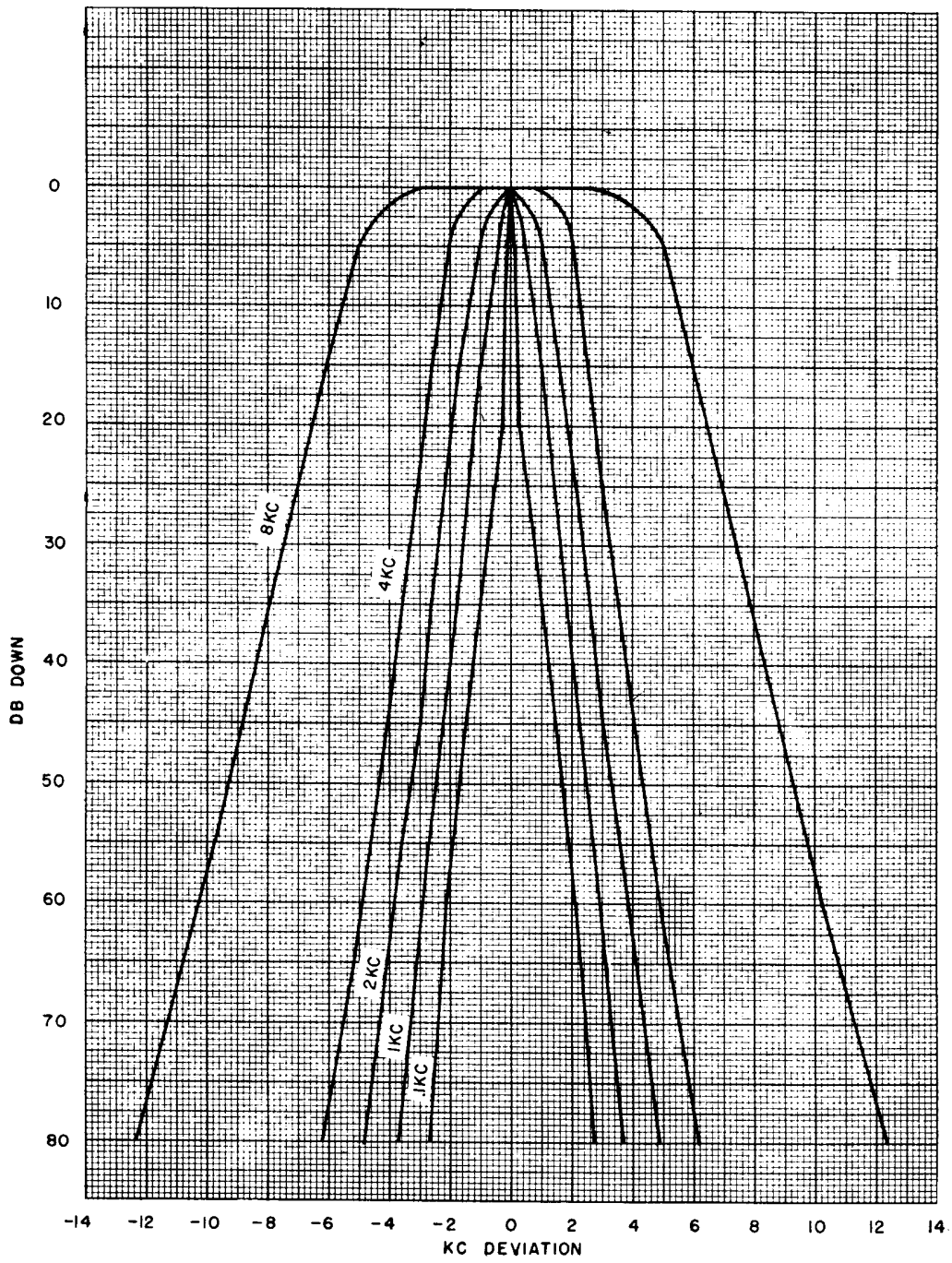
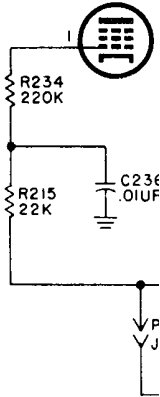

Figure 82. If. selectivity curve.

1ST R-F AMPL
V202
6BJ6



NOTES :

1. UNLESS OTHERWISE SHOWN, RESISTORS ARE IN OHMS, CAPACITORS ARE IN UUF.
2. SWITCH S107 SHOWN IN AGC POSITION.

455KC FROM
5TH I-F AMPL
V505

AGC I-F AMPL
V509
6BJ6

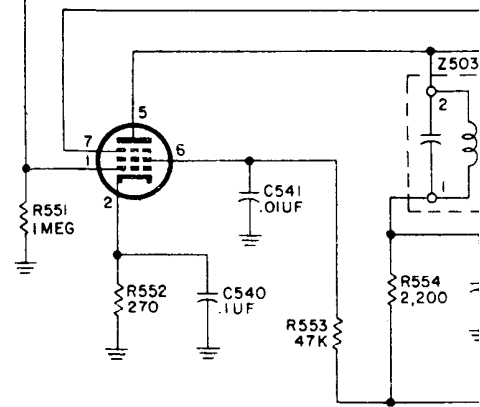

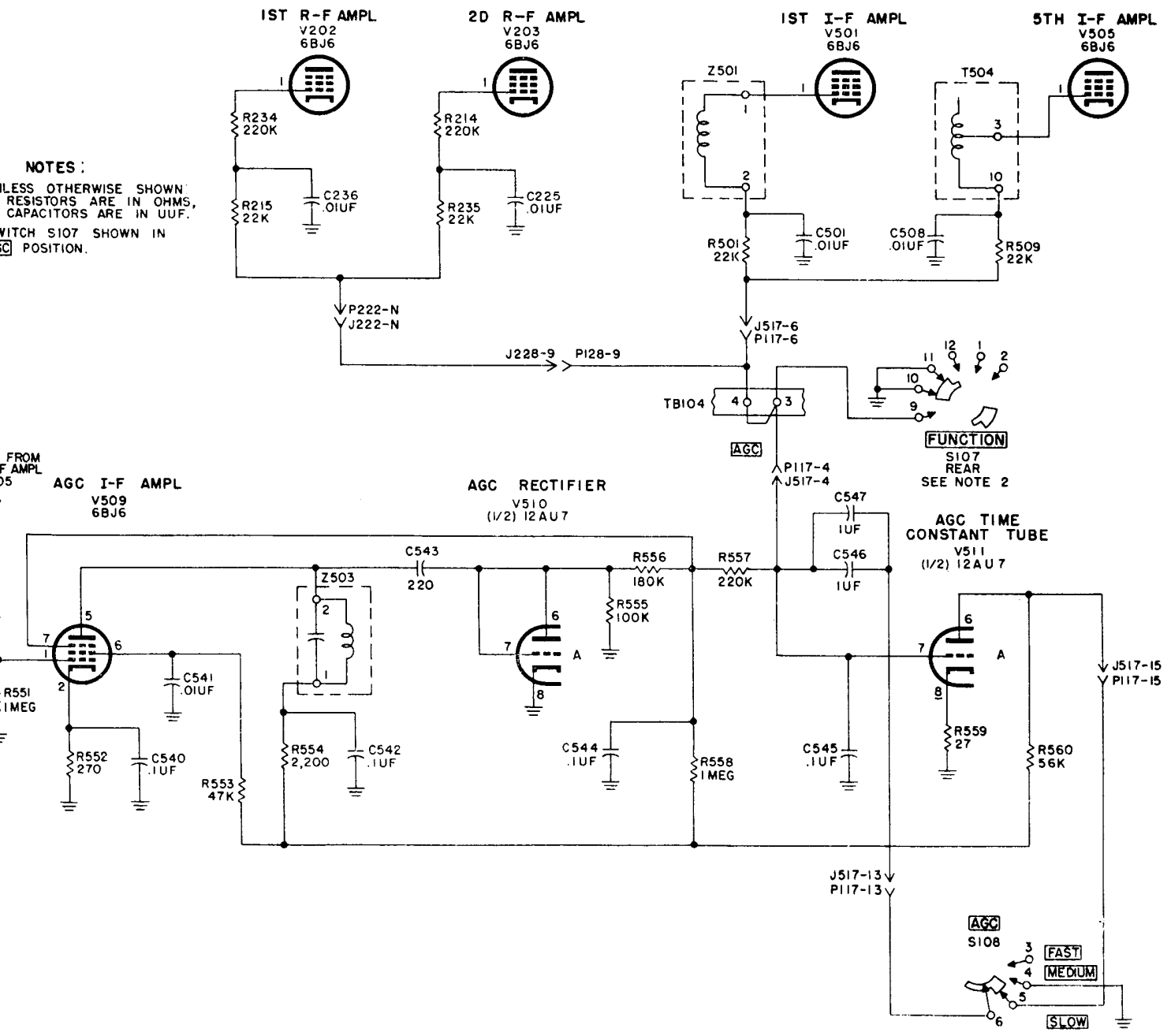
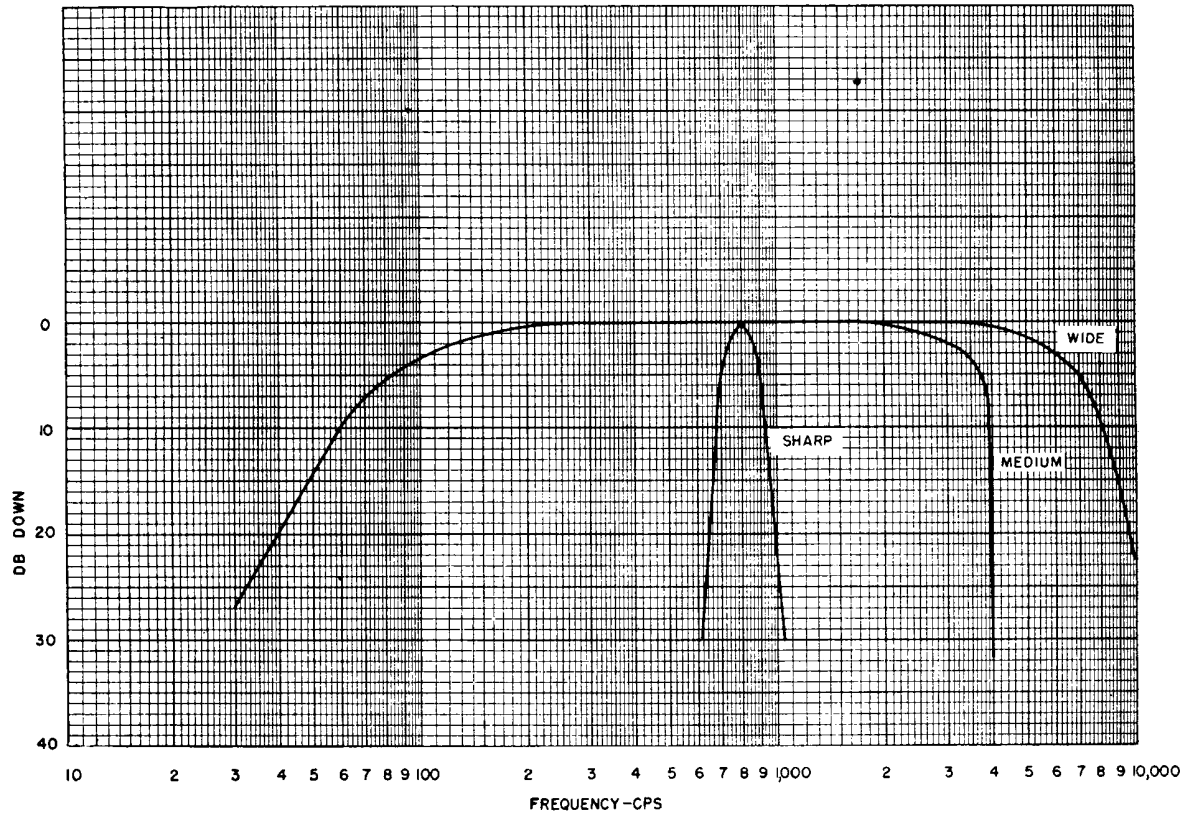

Figure 86. Age voltage distribution.



TM 855-93

Figure 83. Overall audio response chart.

CHAPTER 7

SHIPMENT AND LIMITED STORAGE AND DEMOLITION TO PREVENT ENEMY USE

Section I. SHIPMENT AND LIMITED STORAGE

134. Disassembly

The following instructions are presented as a guide for preparing Radio Receiver R-389/URR for transportation and storage.

a. Disconnect the antenna lead-in cable, Power Cable Assembly CX-1358/U, and all connections to the auxiliary equipment, if used.

b. Disconnect the headphones from the front panel.

c. Remove the receiver from the rack.

135. Repacking for Shipment or Limited Storage

a. The procedure for repacking for shipment or limited storage depends on the available ma-

terial and the conditions under which the equipment is to be shipped or stored. For repacking, follow the procedure given in paragraphs 6 and 14 in reverse order.

b. Whenever practicable, place a dehydrating agent, such as silica gel, inside the receiver. Wrap the receiver and spare parts box in corrugated paper, and protect each package with a waterproof barrier. Seal the seams of the paper barrier with waterproof sealing compound or tape. Pack the protected components in a padded wooden crate; provide at least 3 inches of excelsior or similar material between the paper barrier and the packing case.

Section II. DEMOLITION OF MATERIEL TO PREVENT ENEMY USE

136. Authority for Demolition

The demolition procedures outlined in paragraph 137 will be used to prevent the enemy from using or salvaging this equipment. Demolition of the equipment will be accomplished only upon order of the commander.

137. Methods of Destruction

a. Smash. Smash the crystal, controls, tubes, slug racks, coils, switches, capacitors, transformers, and headset, etc.; use sledges, axes, pickaxes, hammers, crowbars, or other heavy tools.

b. Cut. Cut cords and wiring; use axes, hand-axes, or machetes.

c. Burn. Burn cords, resistors, capacitors, coils, wiring, and manuals; use gasoline, kerosene, oil, flame throwers, or incendiary bombs.

d. Bend. Bend cabinet and chassis.

e. Explosives. If explosives are necessary, use firearms, grenades, or TNT.

f. Disposal. Bury or scatter the destroyed parts in slit trenches, fox holes, or other holes, or throw them into streams.

g. Destroy. Destroy everything.

RESISTOR COLOR CODE MARKING (MIL-STD RESISTORS)

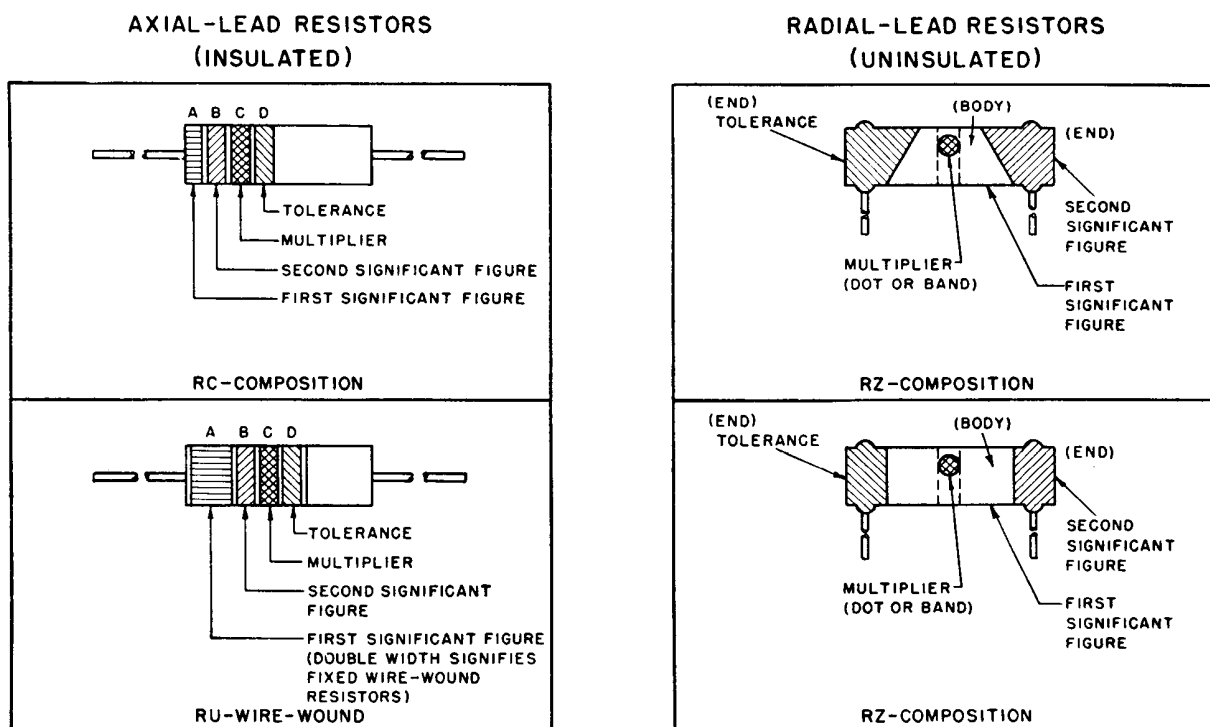

RESISTOR COLOR CODE

BAND A OR BODY*		BAND B OR END*		BAND C OR DOT OR BAND*		BAND D OR END*	
COLOR	FIRST SIGNIFICANT FIGURE	COLOR	SECOND SIGNIFICANT FIGURE	COLOR	MULTIPLIER	COLOR	RESISTANCE TOLERANCE (PERCENT)
BLACK	0	BLACK	0	BLACK	1	BODY	± 20
BROWN	1	BROWN	1	BROWN	10	SILVER	± 10
RED	2	RED	2	RED	100	GOLD	± 5
ORANGE	3	ORANGE	3	ORANGE	1,000		
YELLOW	4	YELLOW	4	YELLOW	10,000		
GREEN	5	GREEN	5	GREEN	100,000		
BLUE	6	BLUE	6	BLUE	1,000,000		
PURPLE (VIOLET)	7	PURPLE (VIOLET)	7				
GRAY	8	GRAY	8	GOLD	0.1		
WHITE	9	WHITE	9	SILVER	0.01		

* FOR WIRE-WOUND-TYPE RESISTORS, BAND A SHALL BE DOUBLE-WIDTH. WHEN BODY COLOR IS THE SAME AS THE DOT (OR BAND) OR END COLOR, THE COLORS ARE DIFFERENTIATED BY SHADE, GLOSS, OR OTHER MEANS.

EXAMPLES (BAND MARKING):

10 OHMS ± 20 PERCENT: BROWN BAND A; BLACK BAND B; BLACK BAND C; NO BAND D.
 4.7 OHMS ± 5 PERCENT: YELLOW BAND A; PURPLE BAND B; GOLD BAND C; GOLD BAND D.

EXAMPLES (BODY MARKING):

10 OHMS ± 20 PERCENT: BROWN BODY; BLACK END; BLACK DOT OR BAND; BODY COLOR ON TOLERANCE END.
 3,000 OHMS ± 10 PERCENT: ORANGE BODY; BLACK END; RED DOT OR BAND; SILVER END.

STD-R1

Figure 84. Resistor color code marking.

CAPACITOR COLOR CODE MARKING (MIL-STD CAPACITORS)

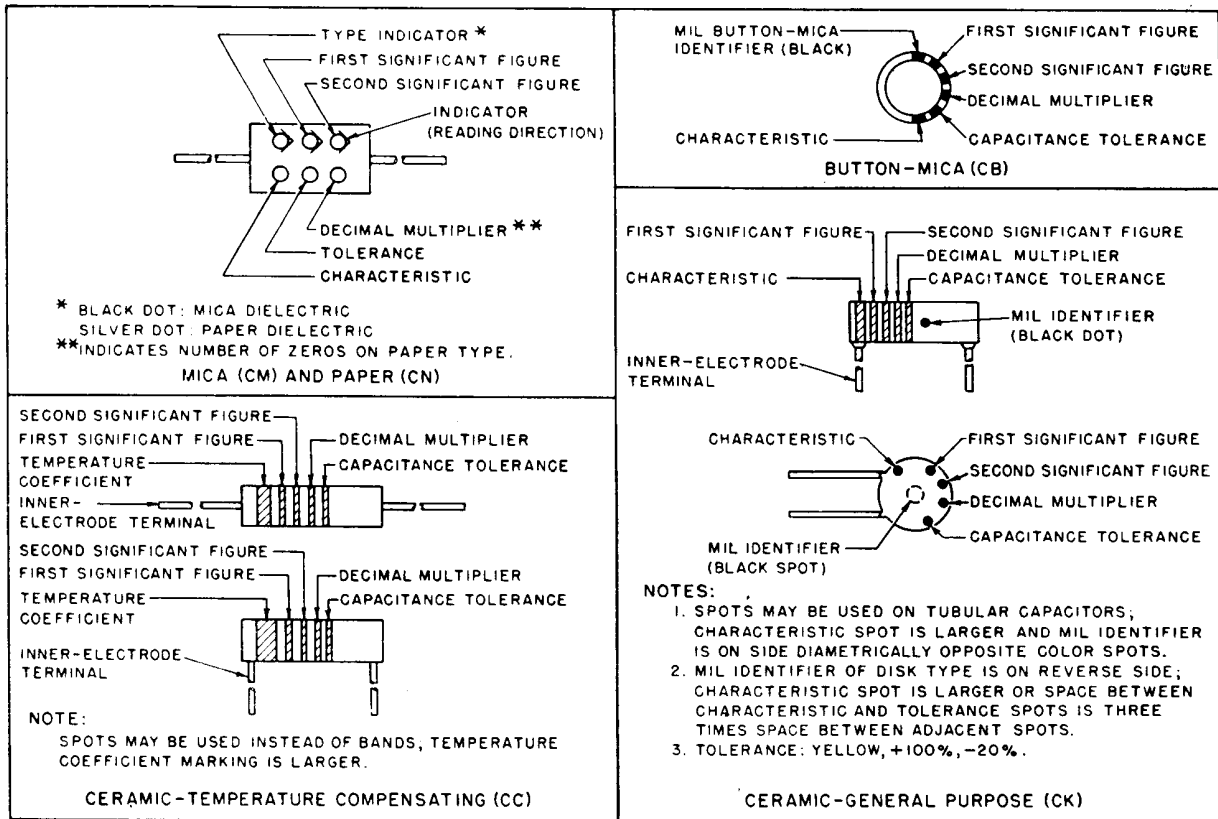

CAPACITOR COLOR CODE

COLOR	SIG FIG.	MULTIPLIER		CHARACTERISTIC ¹				TOLERANCE ²				TEMPERATURE COEFFICIENT (UUF/UF/°C)	
		DECIMAL	NUMBER OF ZEROS	CM	CN	CB	CK	CM	CN	CB	CC		
											OVER 10UUF		10UUF OR LESS
BLACK	0	1	NONE		A			20	20	20	20	2	ZERO
BROWN	1	10	1	B	E	B	W					1	-30
RED	2	100	2	C	H		X	2		2	2		-80
ORANGE	3	1,000	3	D	J	D			30				-150
YELLOW	4	10,000	4	E	P								-220
GREEN	5		5	F	R						5	0.5	-330
BLUE	6		6		S								-470
PURPLE (VIOLET)	7		7		T	W							-750
GRAY	8		8				X					0.25	+30
WHITE	9		9								10	1	-330(±500) ³
GOLD		0.1						5		5			+100
SILVER		0.01						10	10	10			

1. LETTERS ARE IN TYPE DESIGNATIONS GIVEN IN MIL-C SPECIFICATIONS.
 2. IN PERCENT, EXCEPT IN UUF FOR CC-TYPE CAPACITORS OF 10 UUF OR LESS.
 3. INTENDED FOR USE IN CIRCUITS NOT REQUIRING COMPENSATION.

STD-CI

Figure 85. Capacitor color code marking.

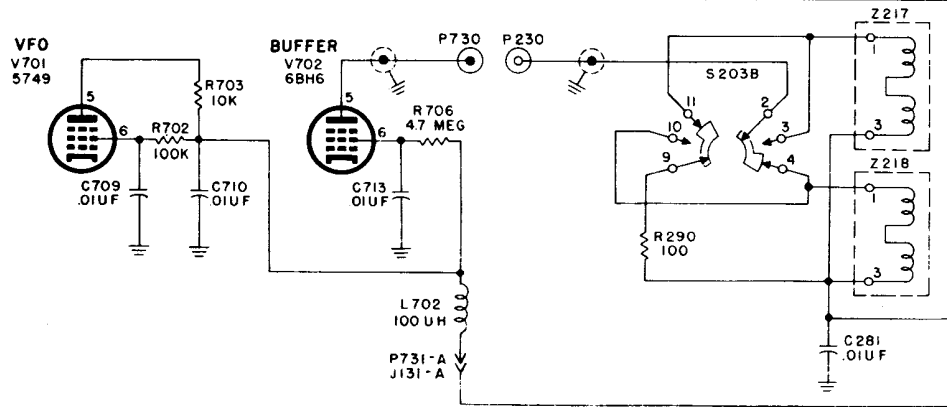
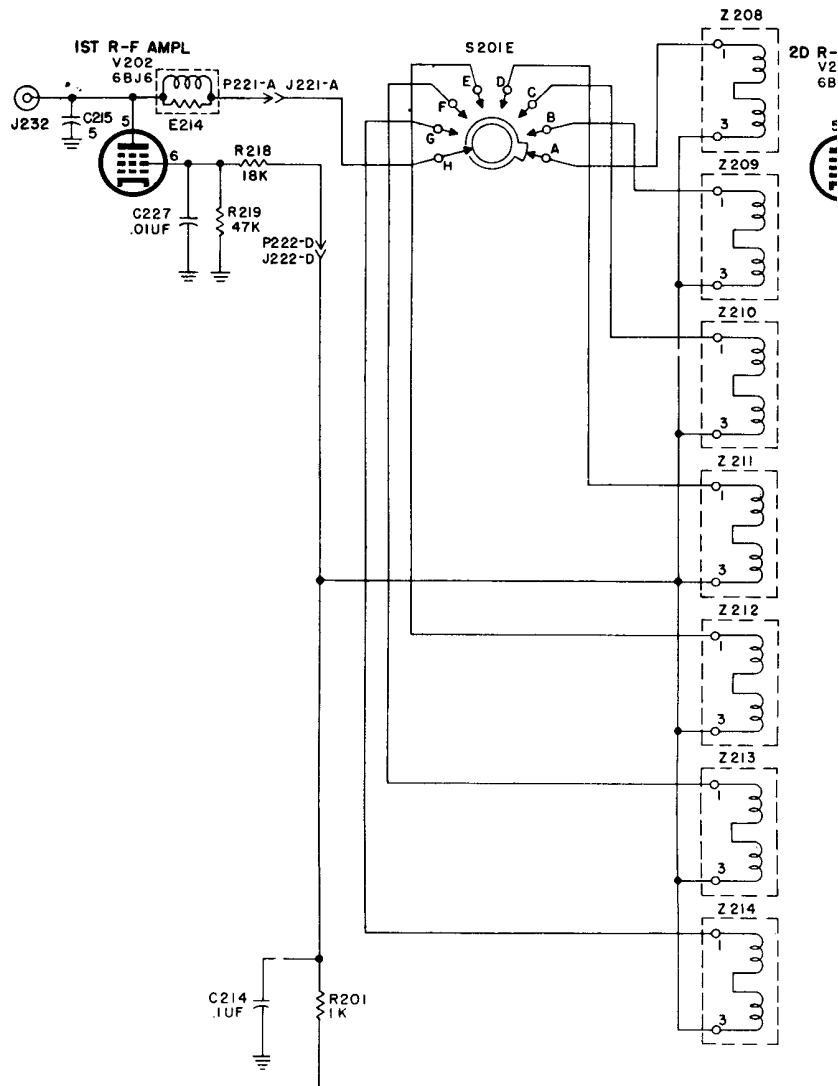

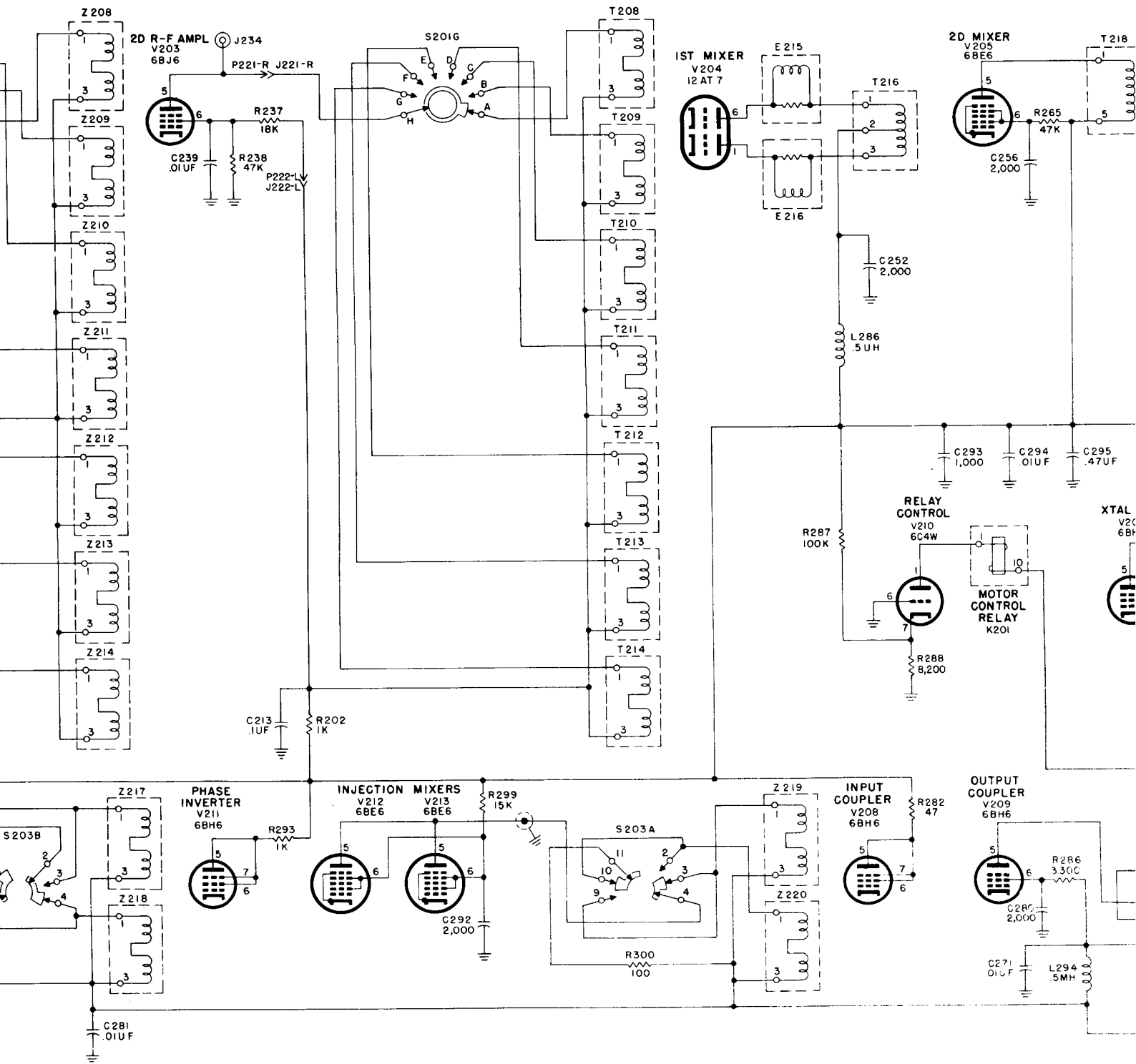

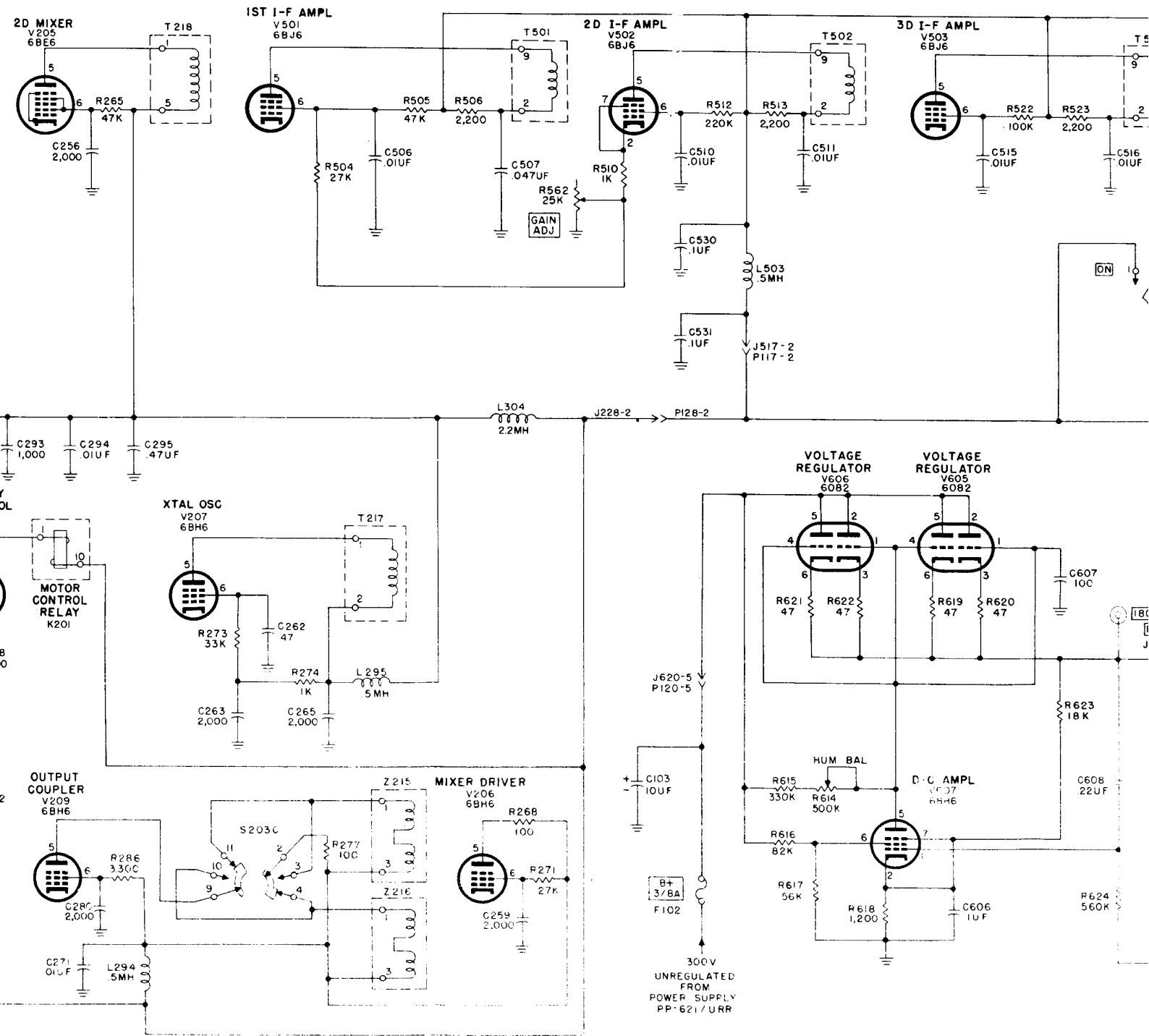
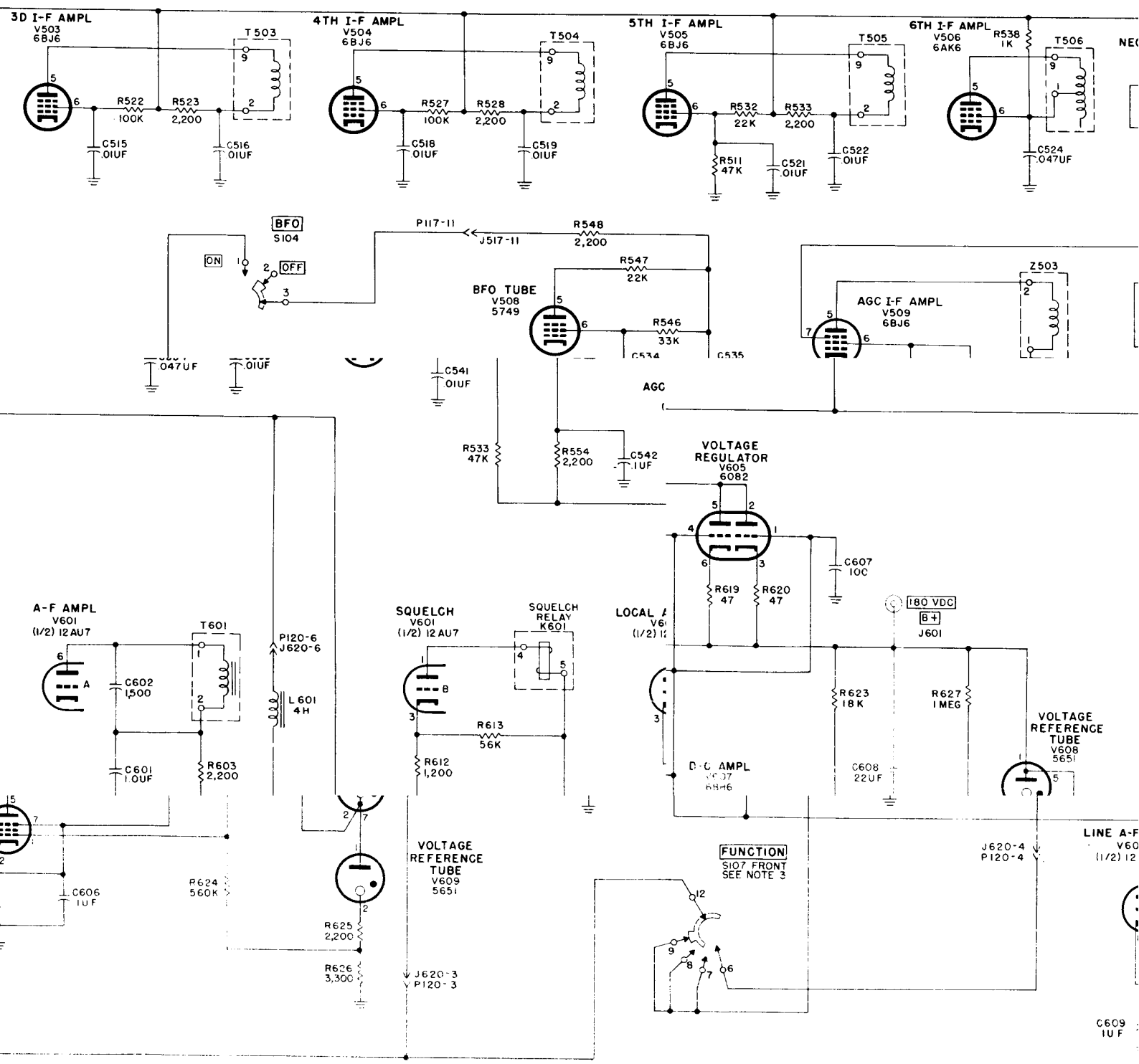
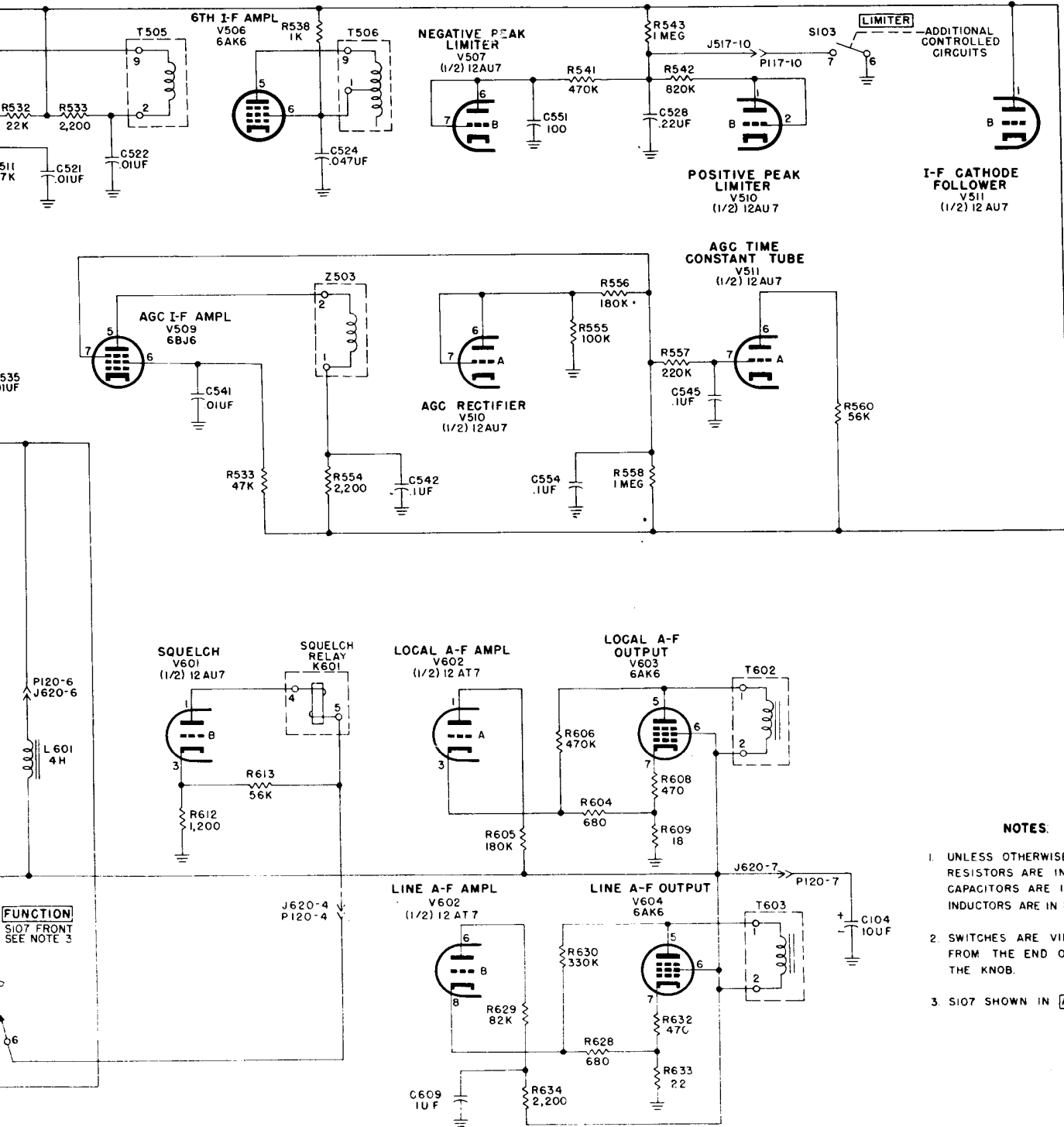
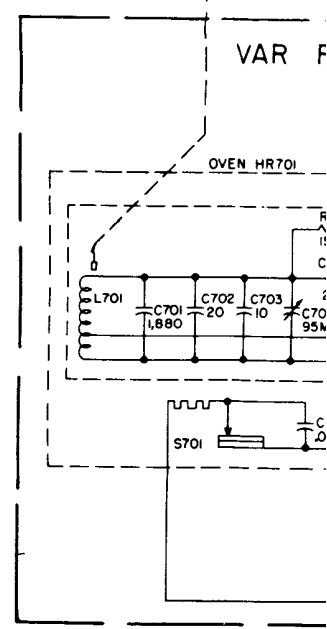
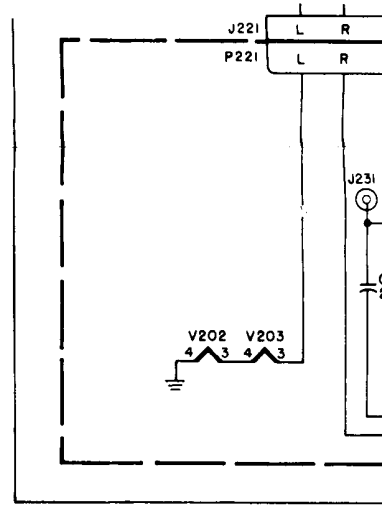
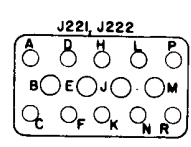
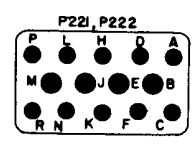

Figure 87. B+ voltage distribution.





- 58 P120-1 AF (902)
- 59 P118-3 180V PS (902)
- 60 P118-4 180V PS (935)
- 61 P120-2 AF (935)



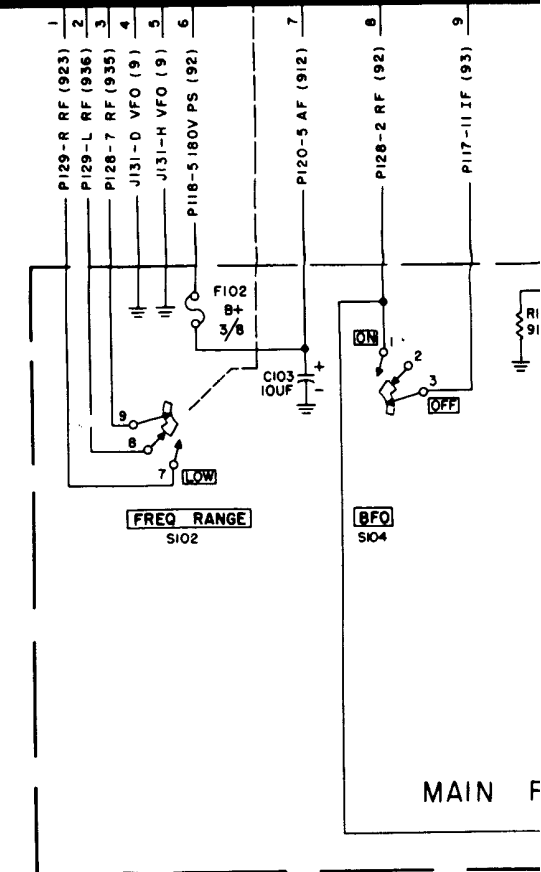
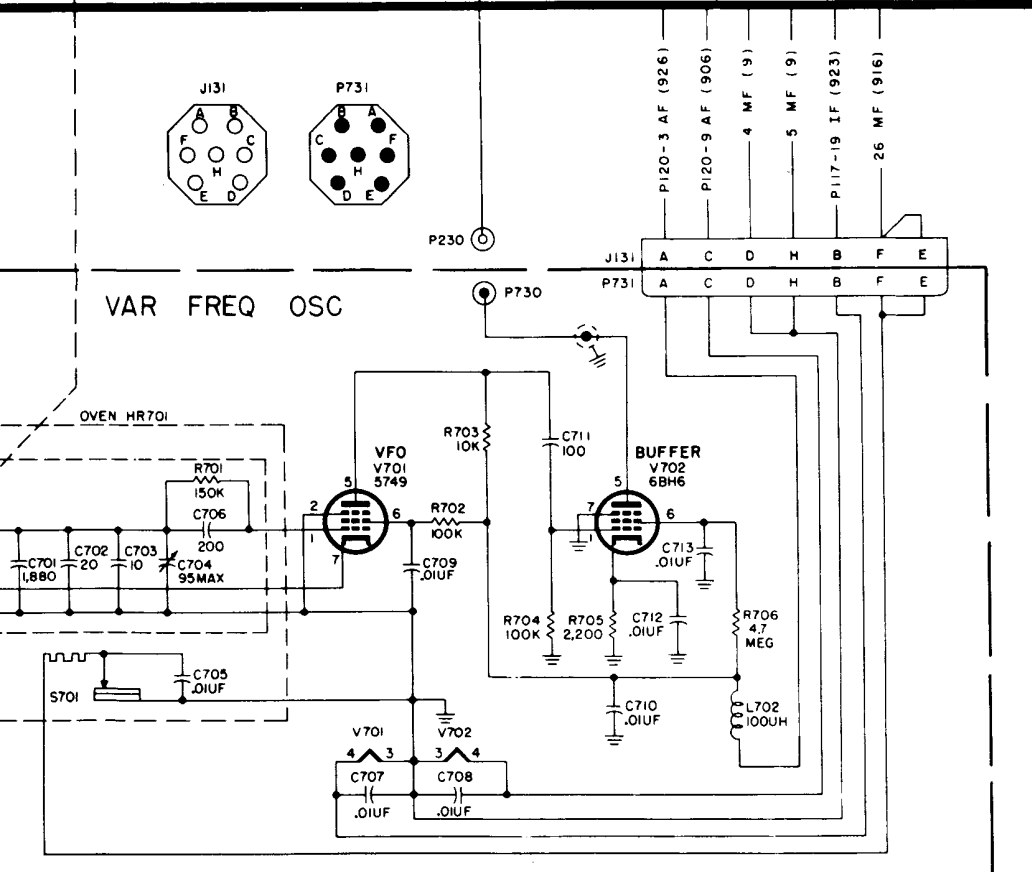
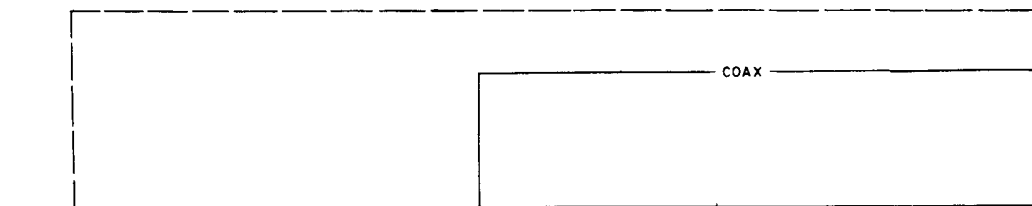
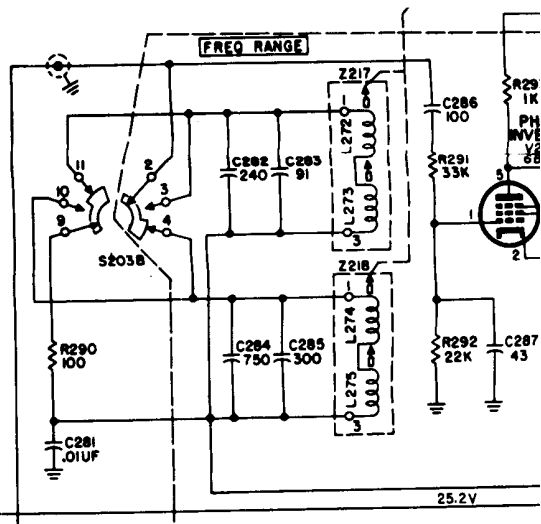
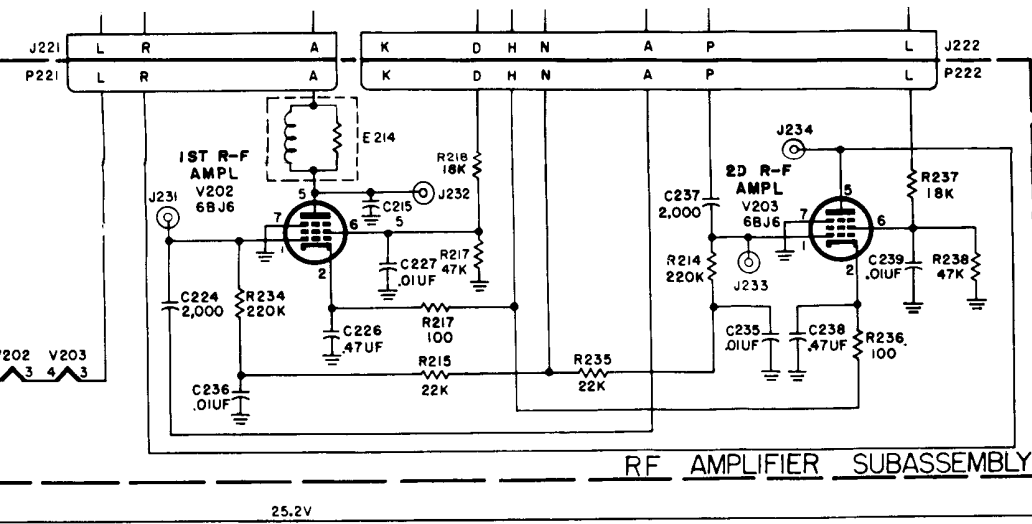

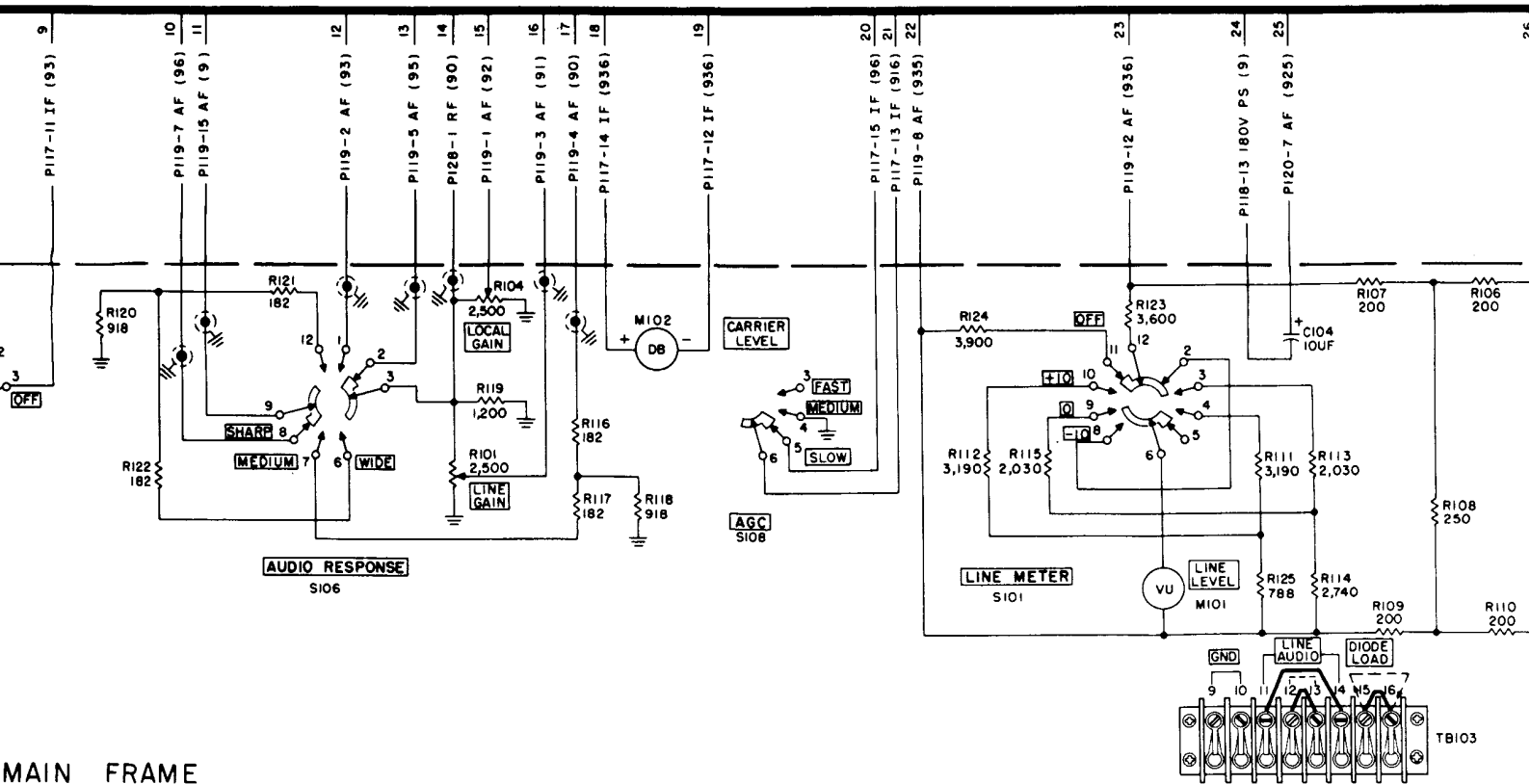
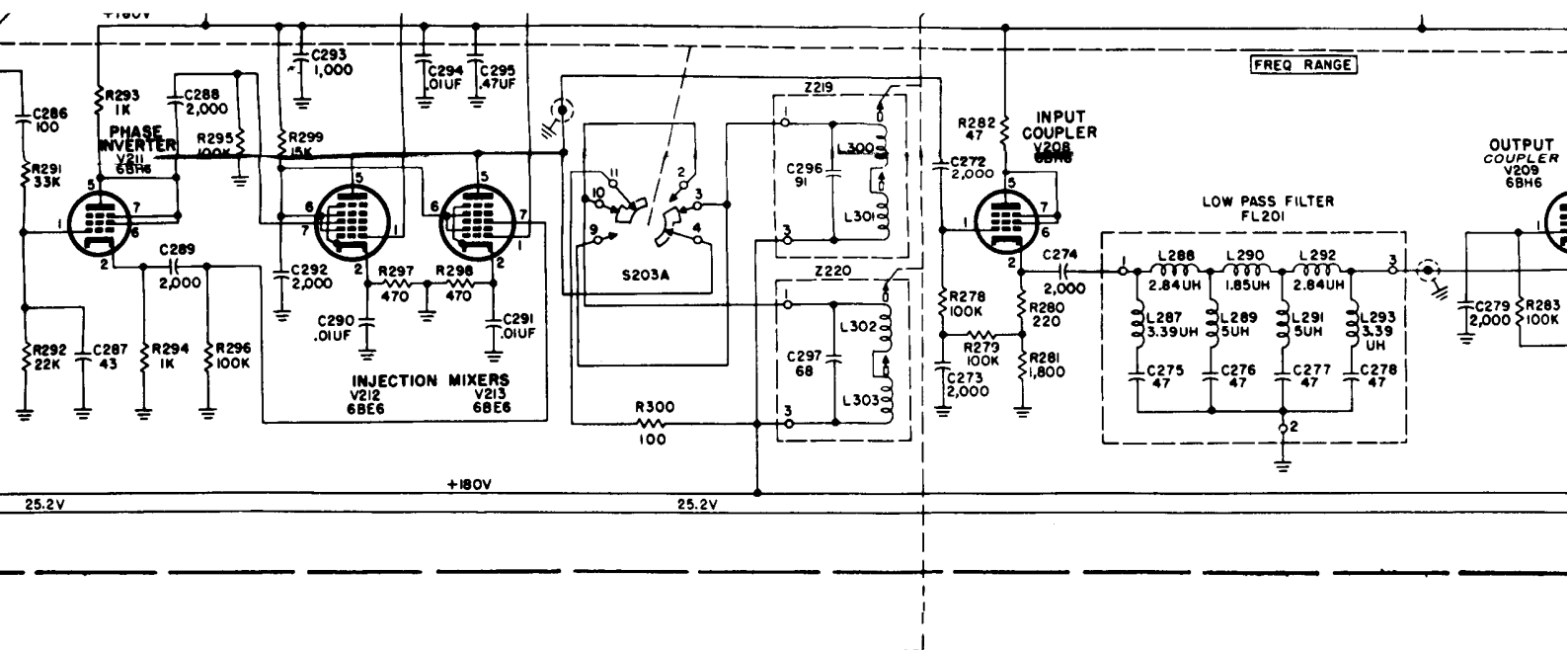
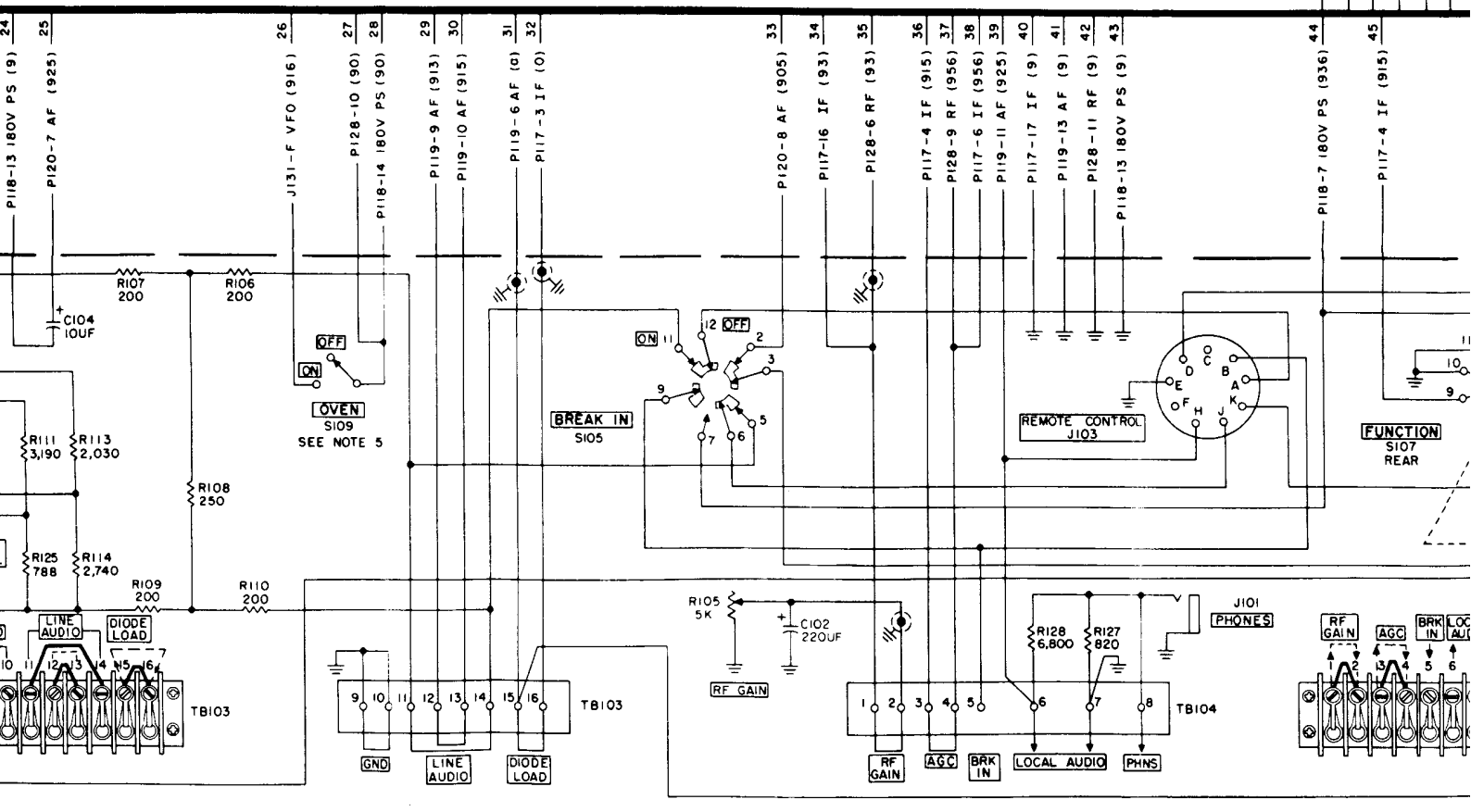
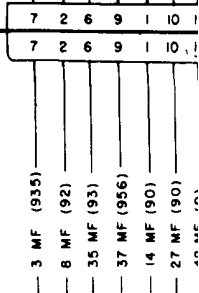
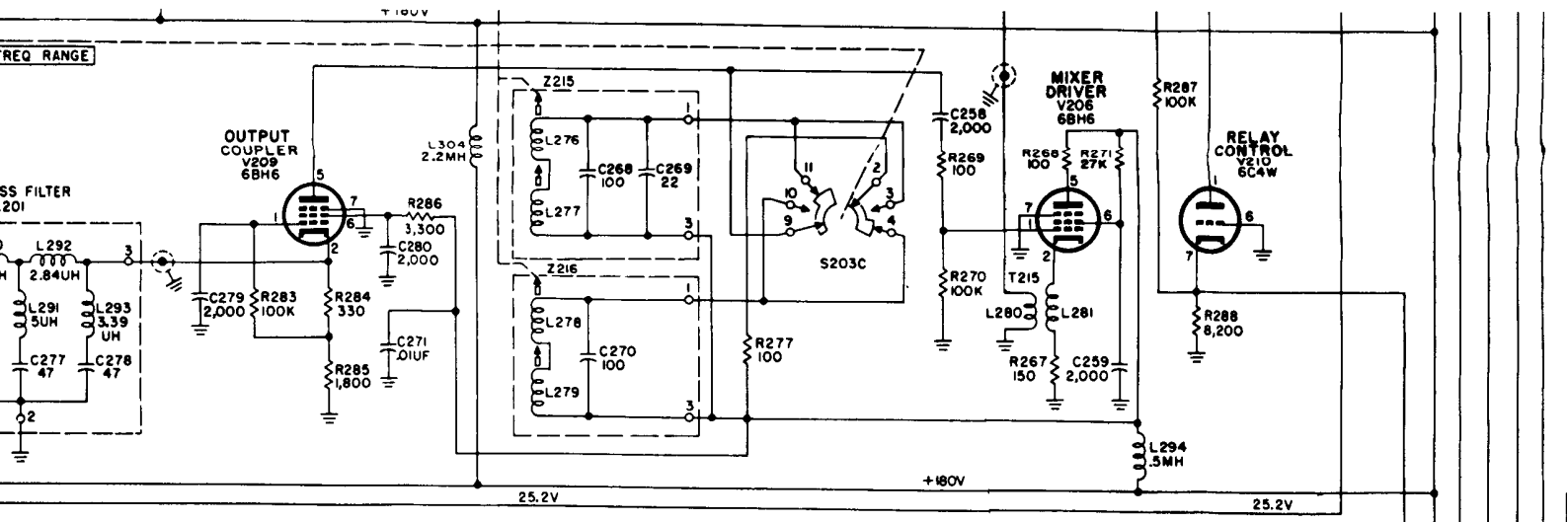
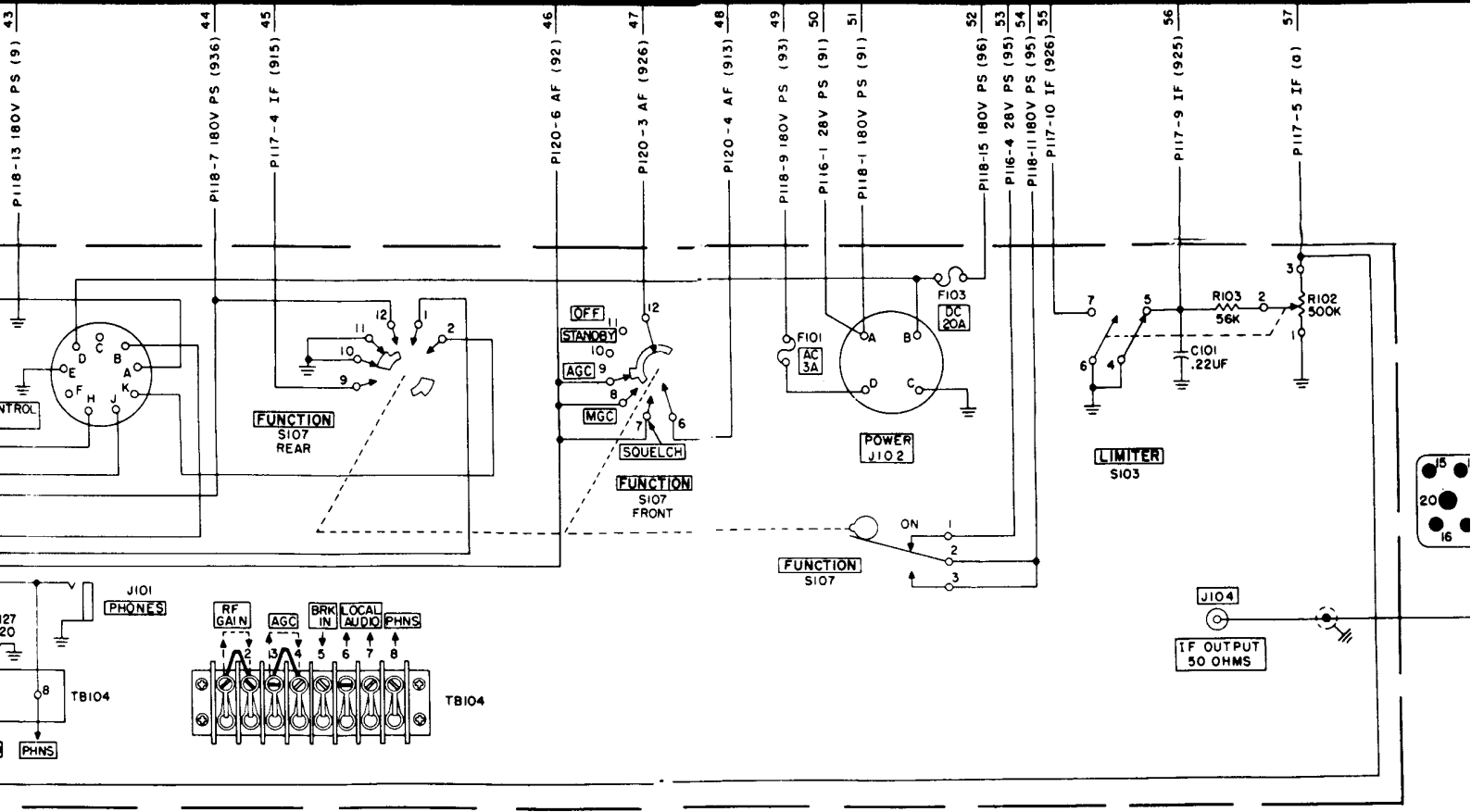
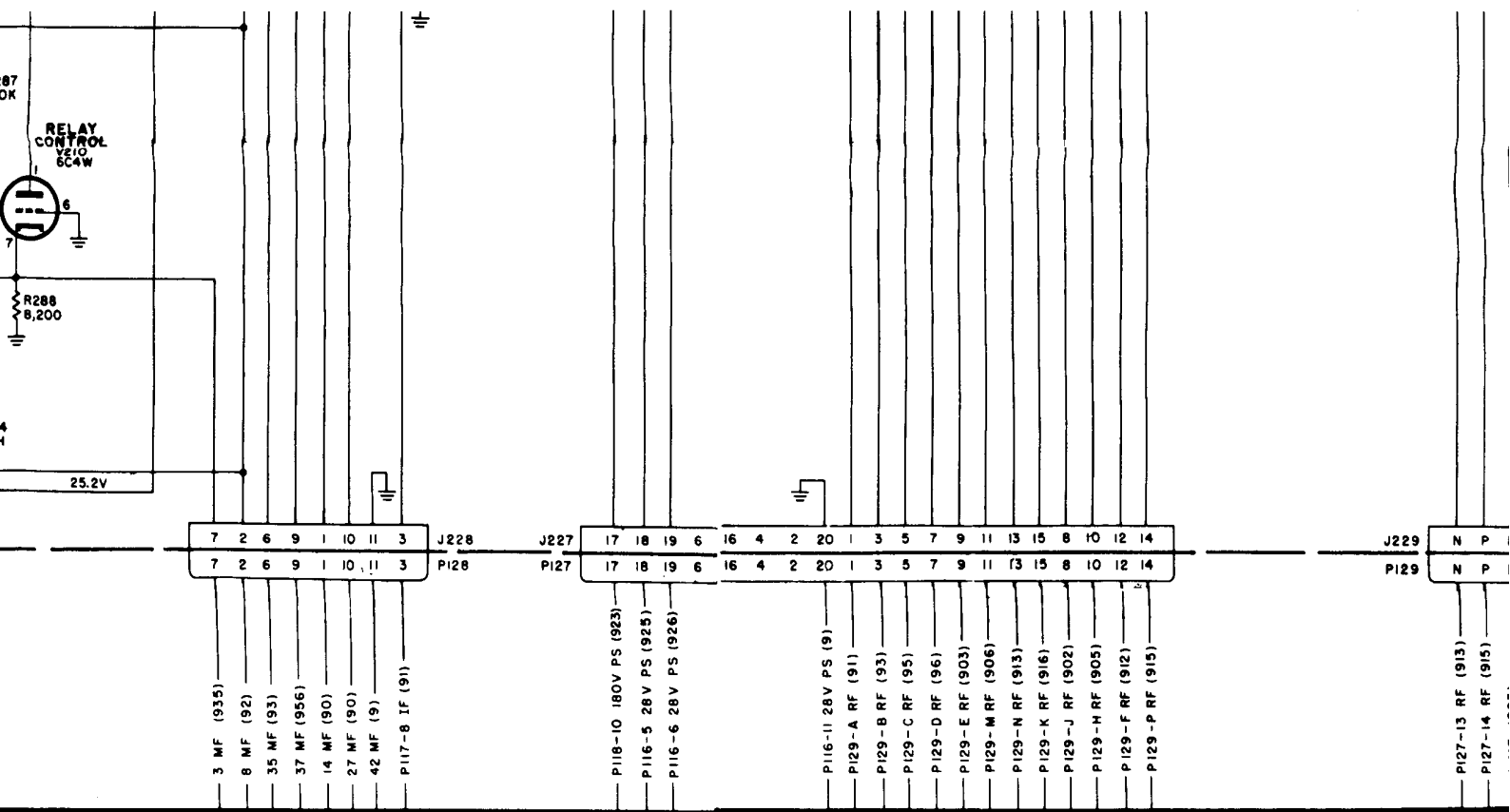
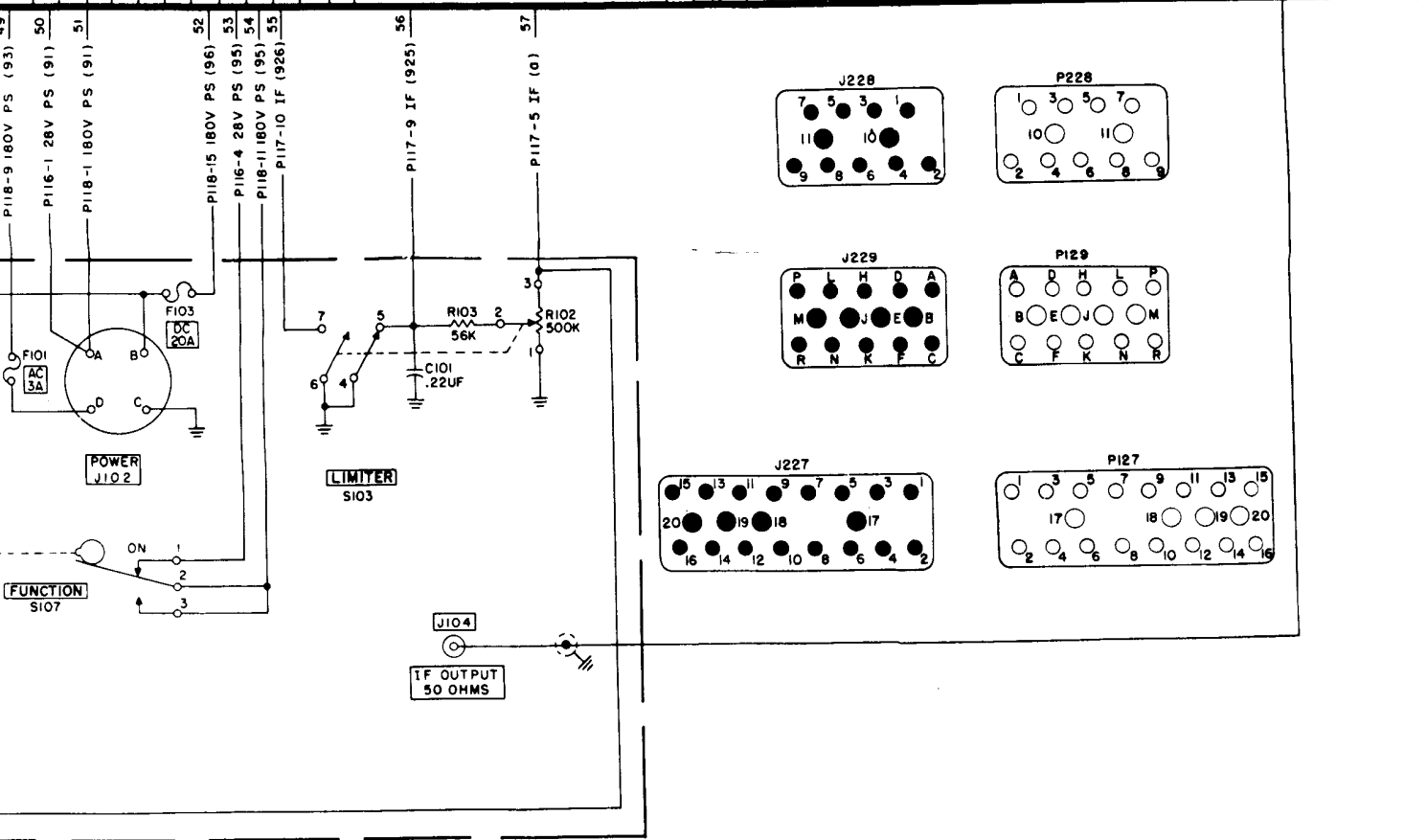
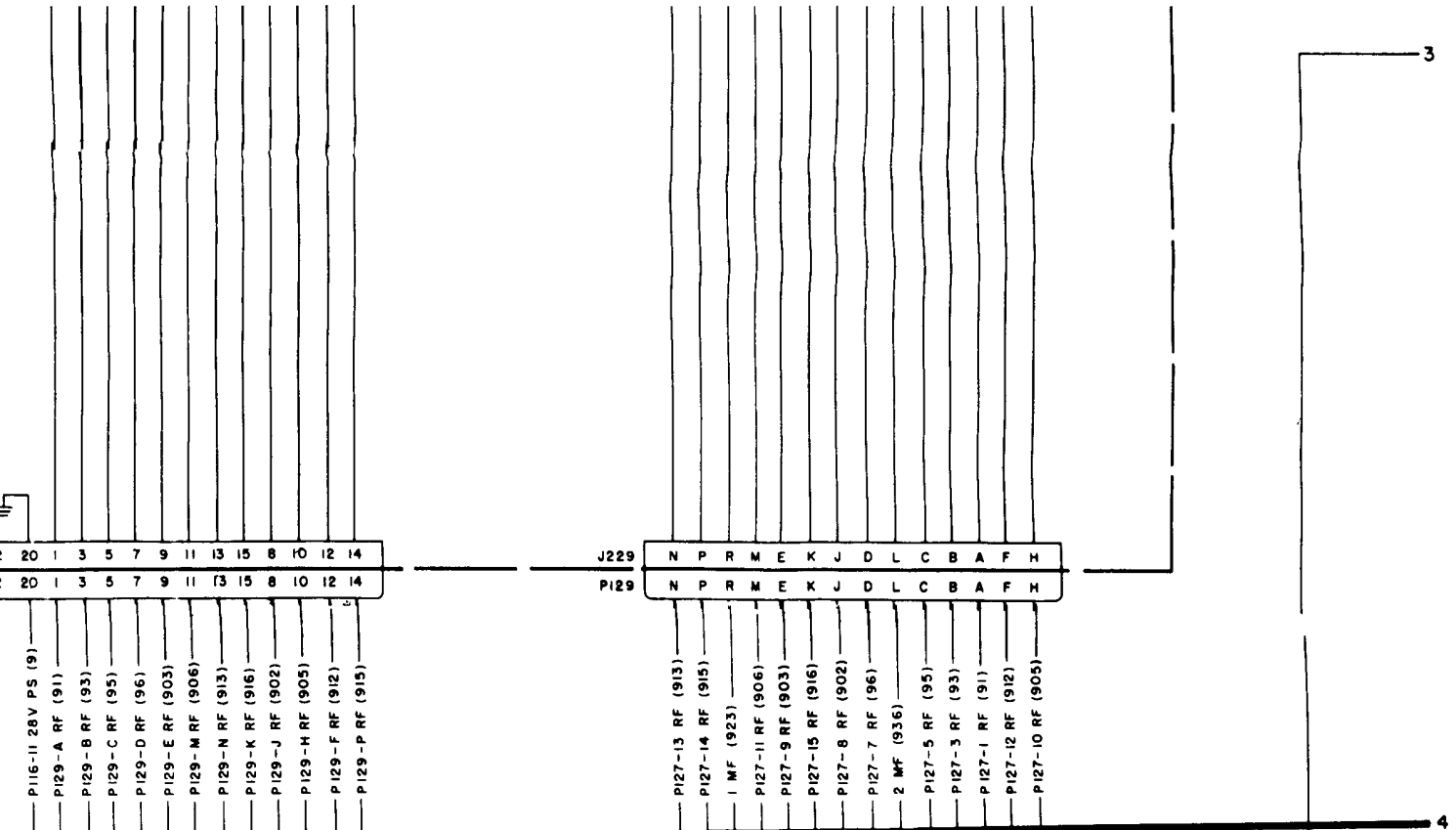

Figure 88. Subchassis and interconnection diagram.



and interconnection diagram.





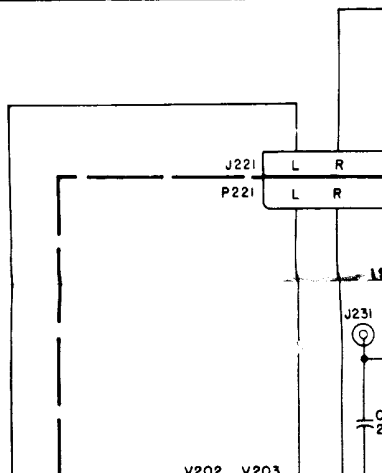
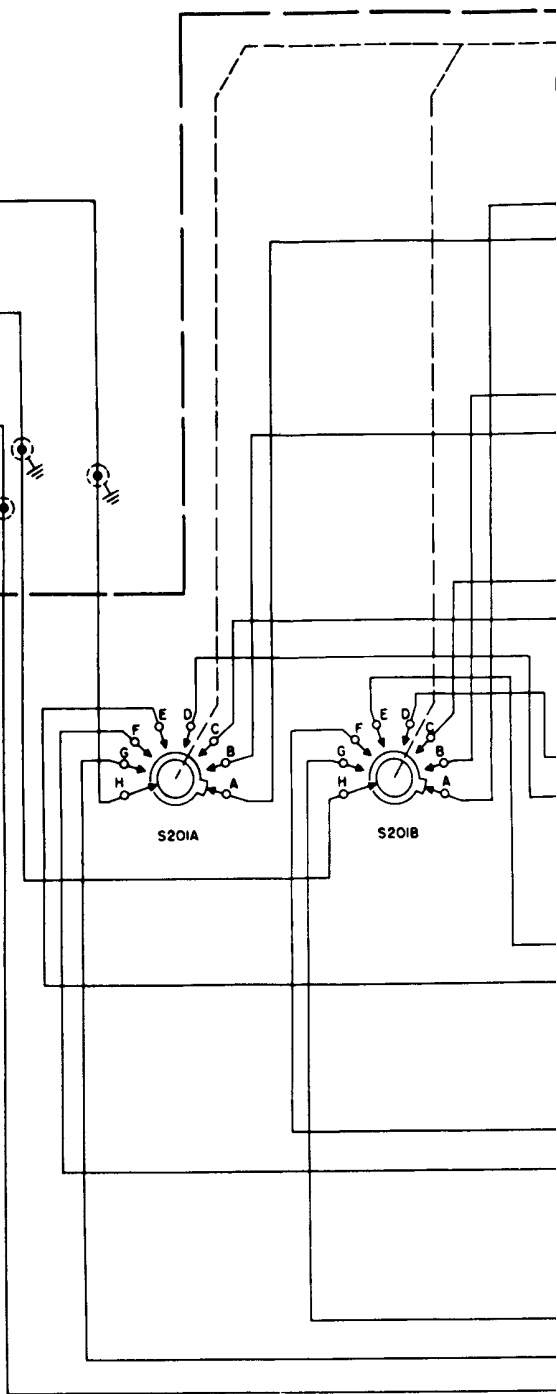
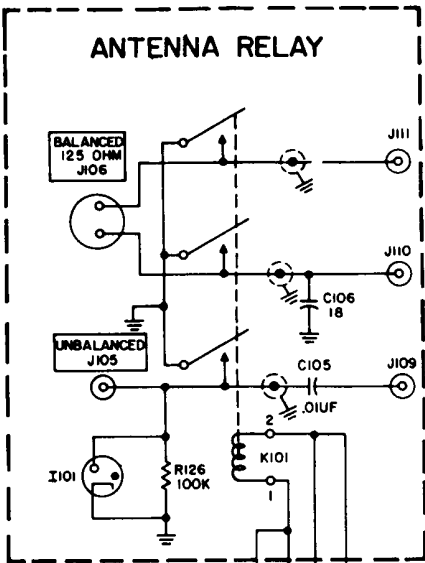

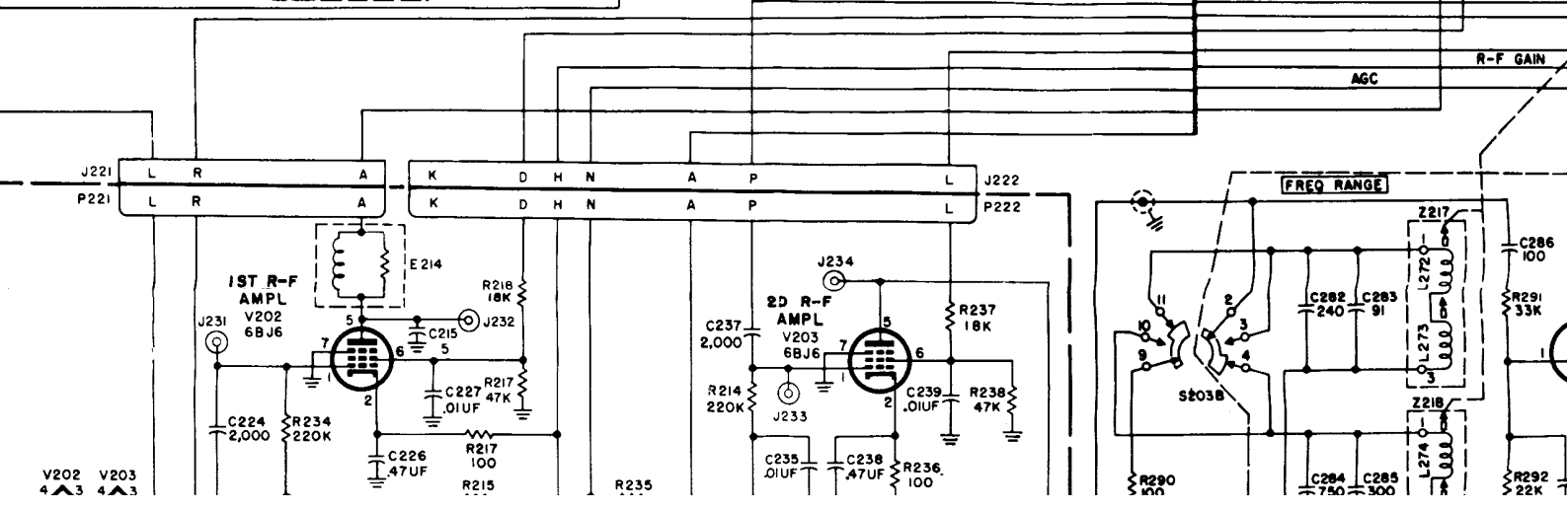
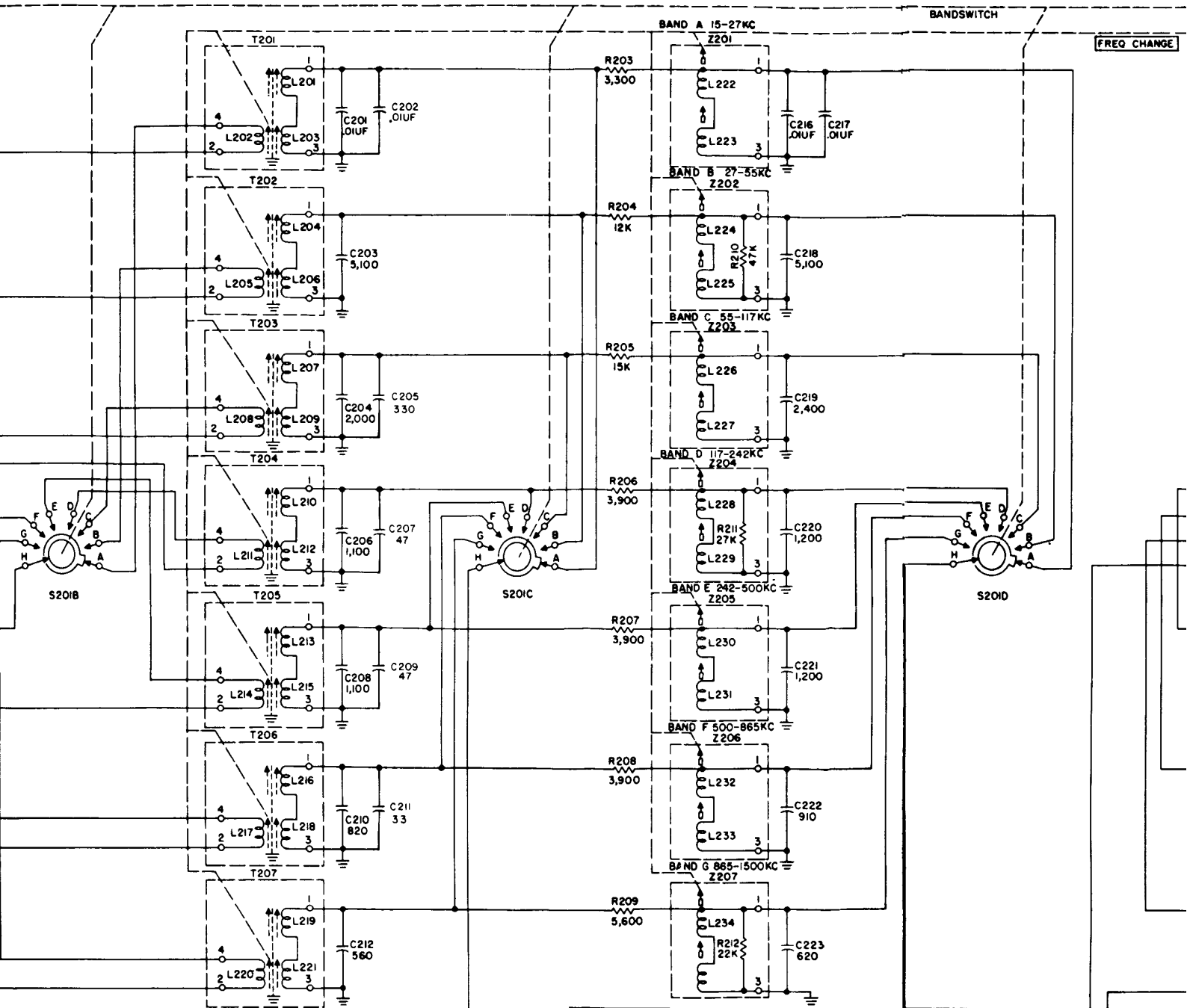

V202 V203
4 3 4 3

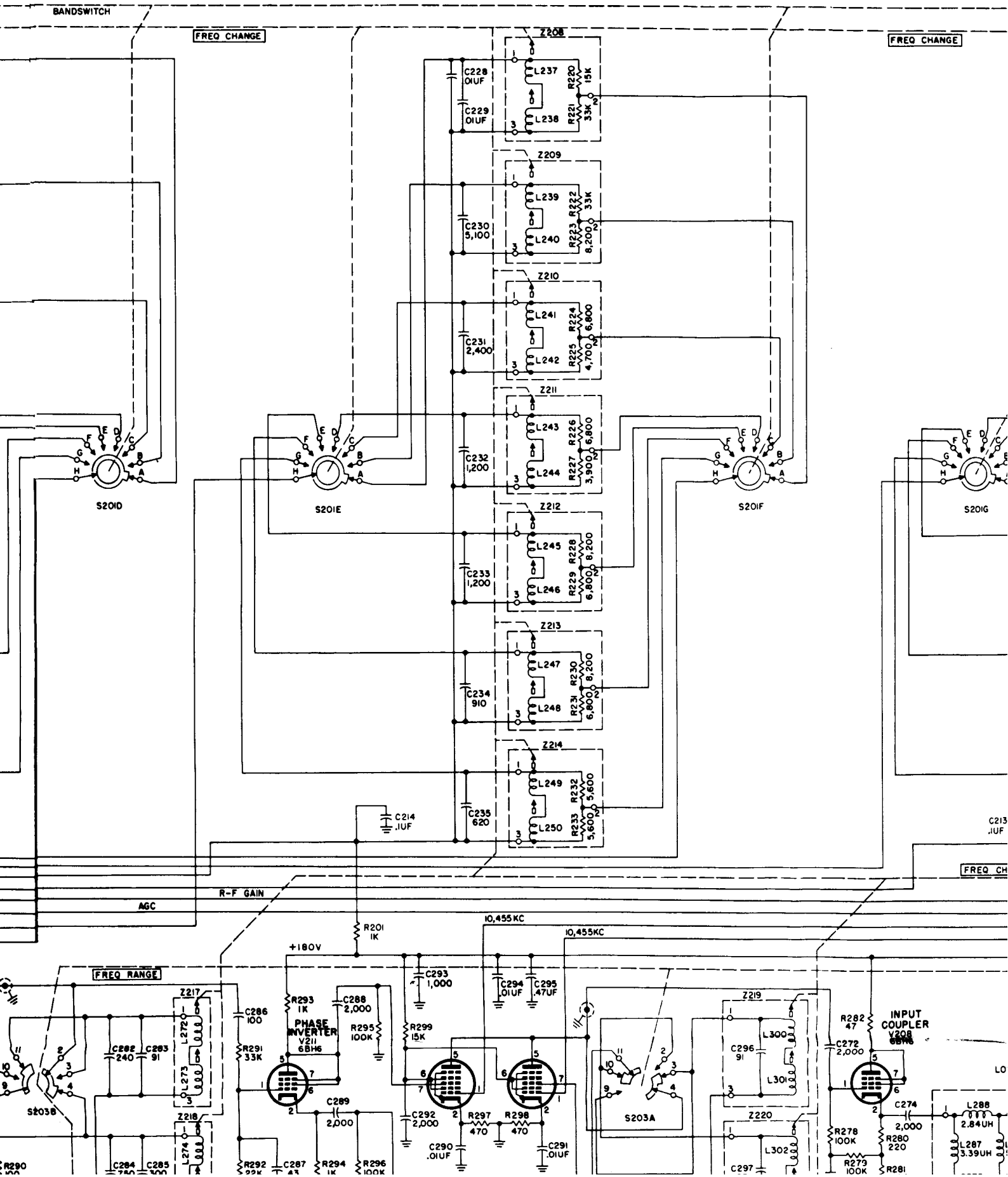

BANDSWITCH

FREQ CHANGE

FREQ CHANGE

S20ID

S20IE

S20IF

S20IG

C213
.1UF

FREQ CH

AGC

R-F GAIN

FREQ RANGE

+180V

10,455KC

10,455KC

INPUT COUPLER
V208
6896

S203B

S203A

R290

LO

LO

S290

S281

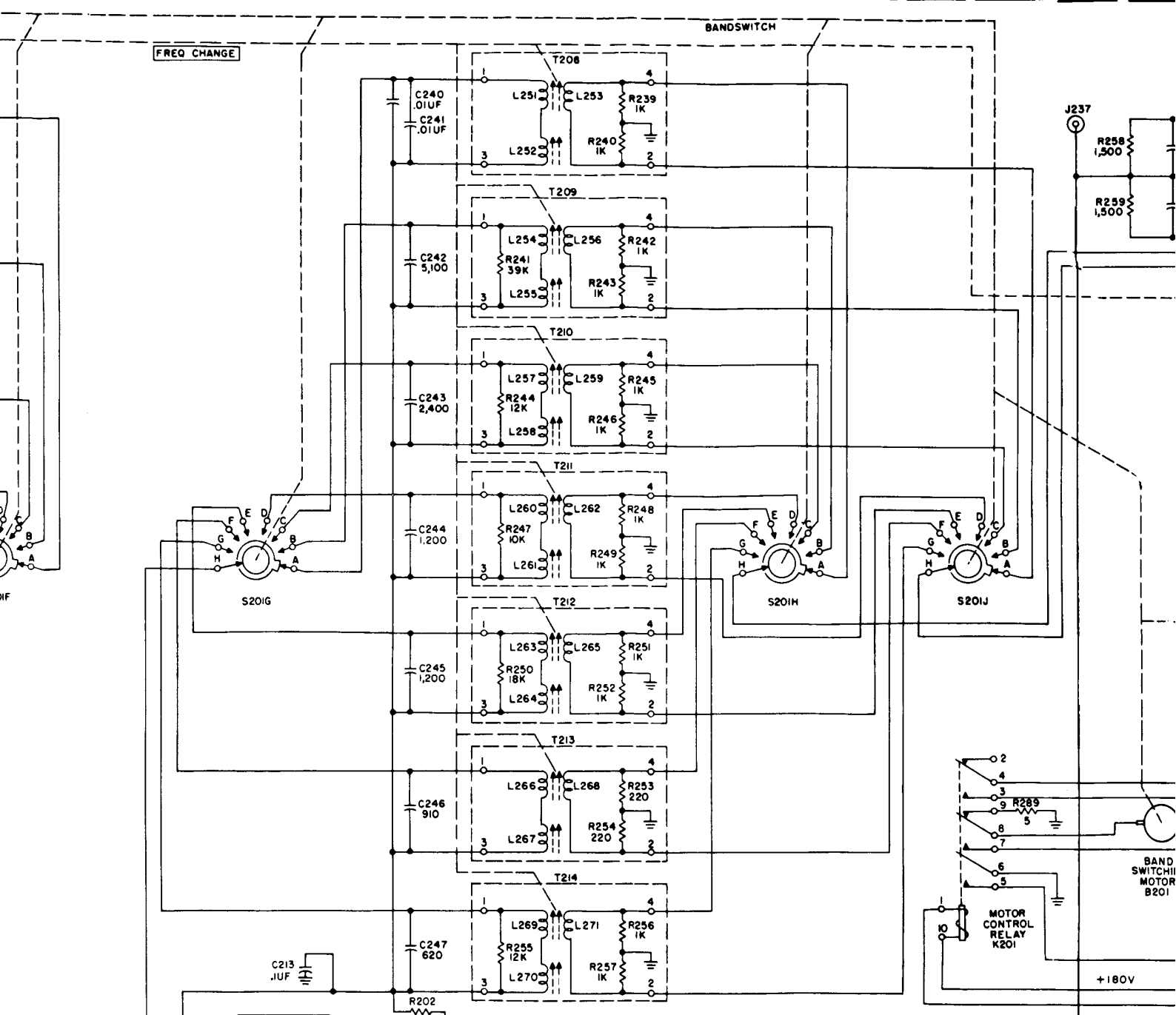

R-F GAIN
 AGC
 10, 455 KC
 10, 455 KC

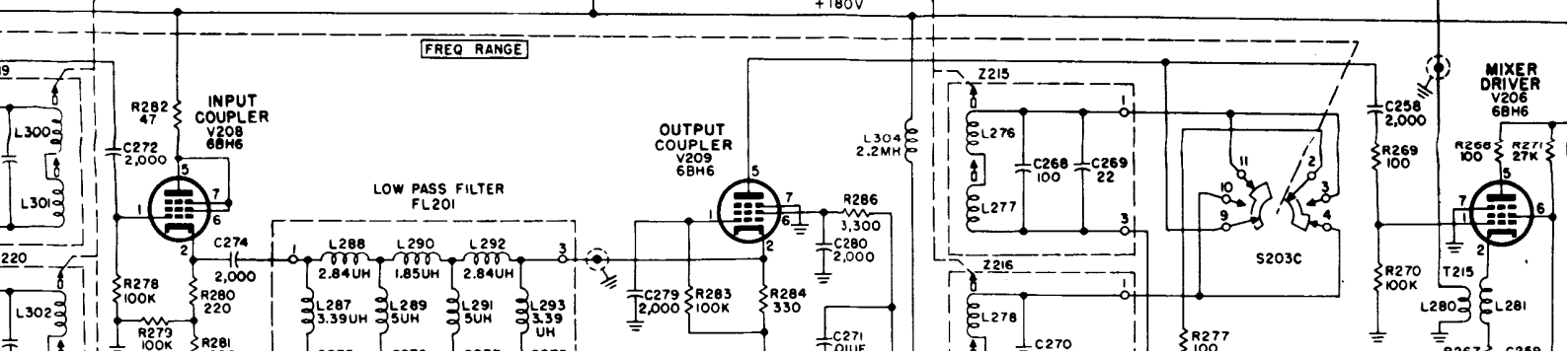

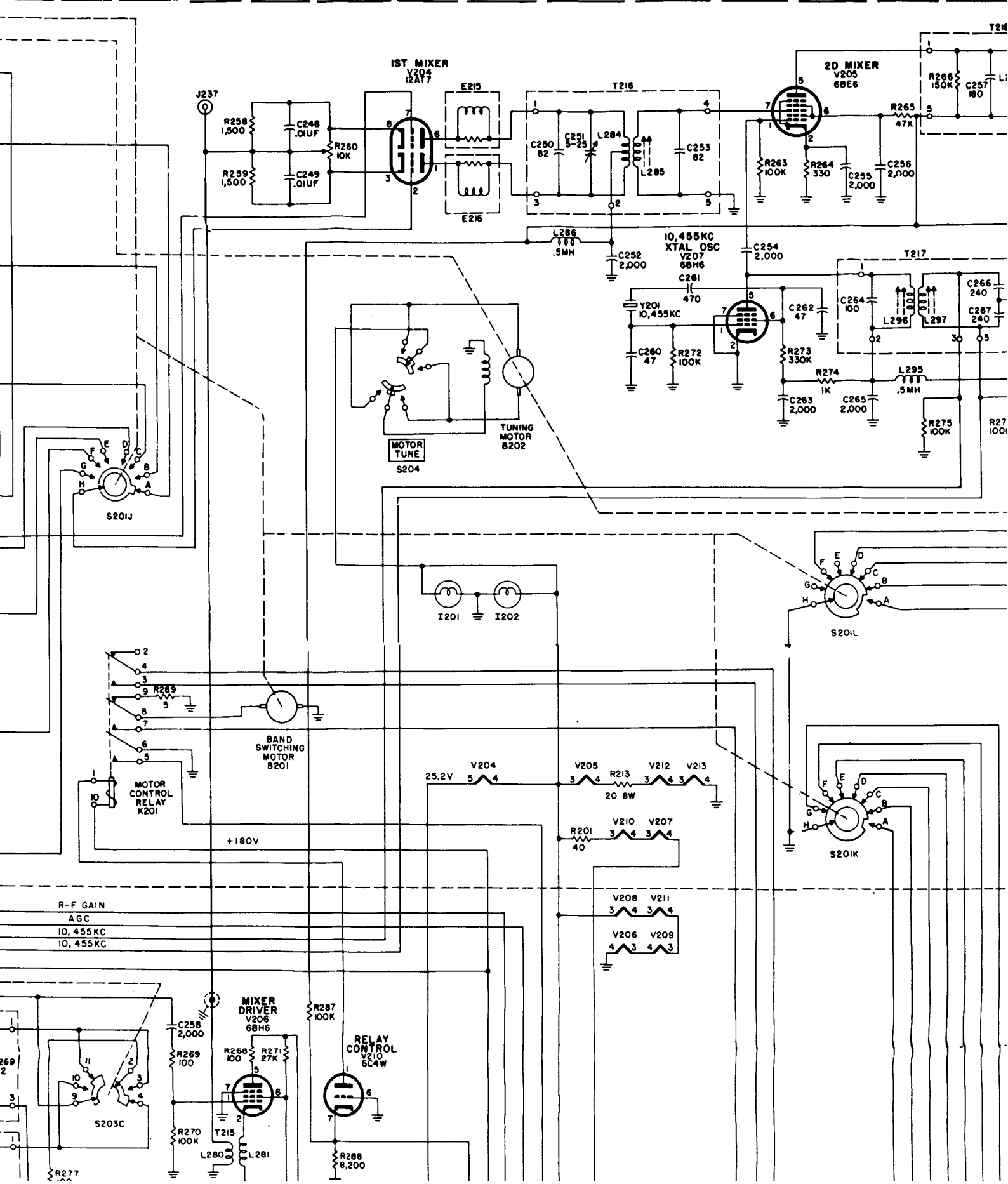

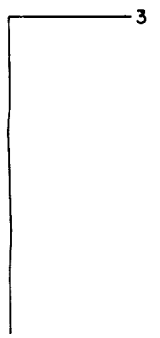
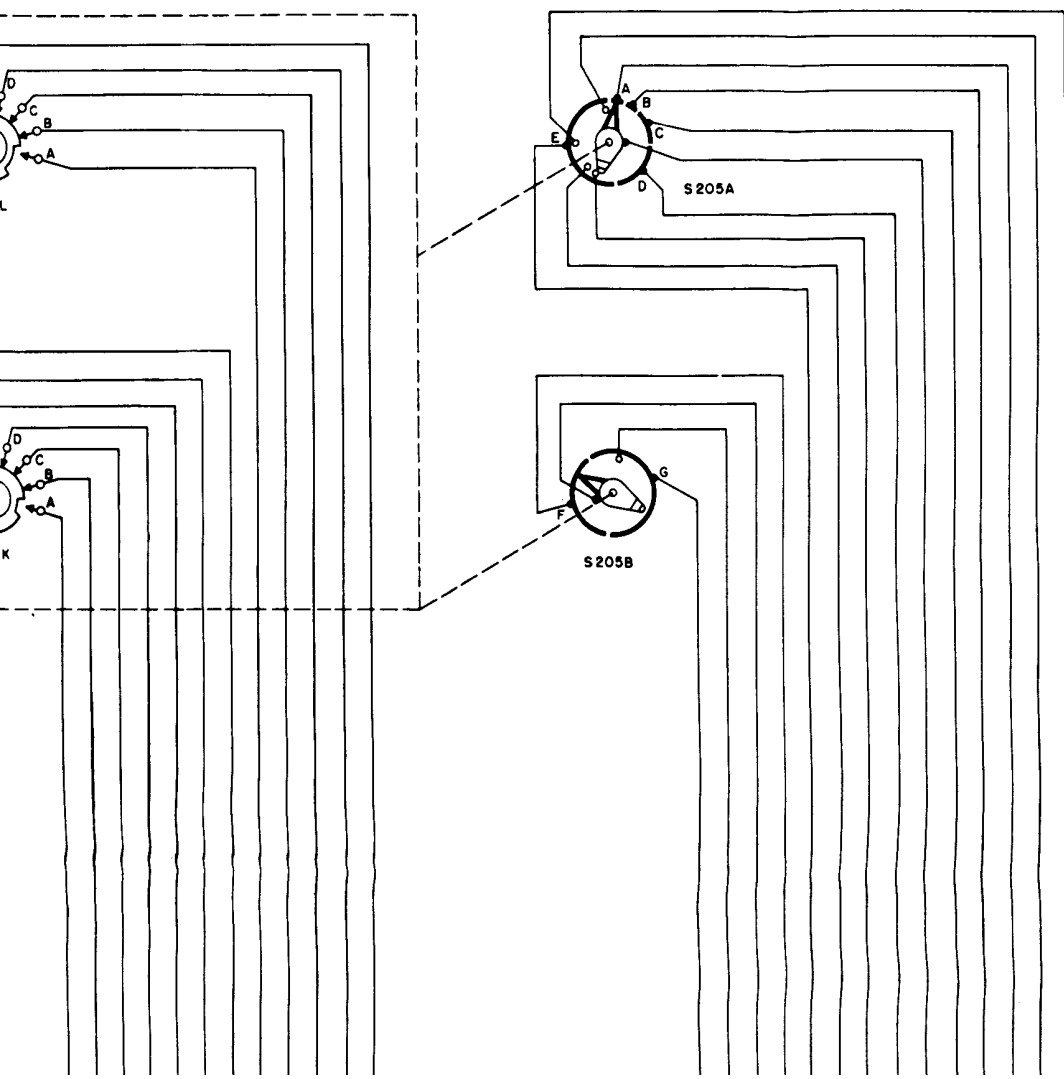
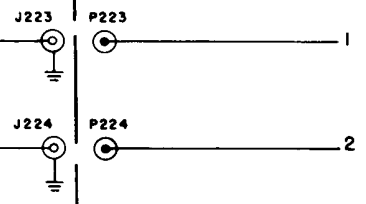
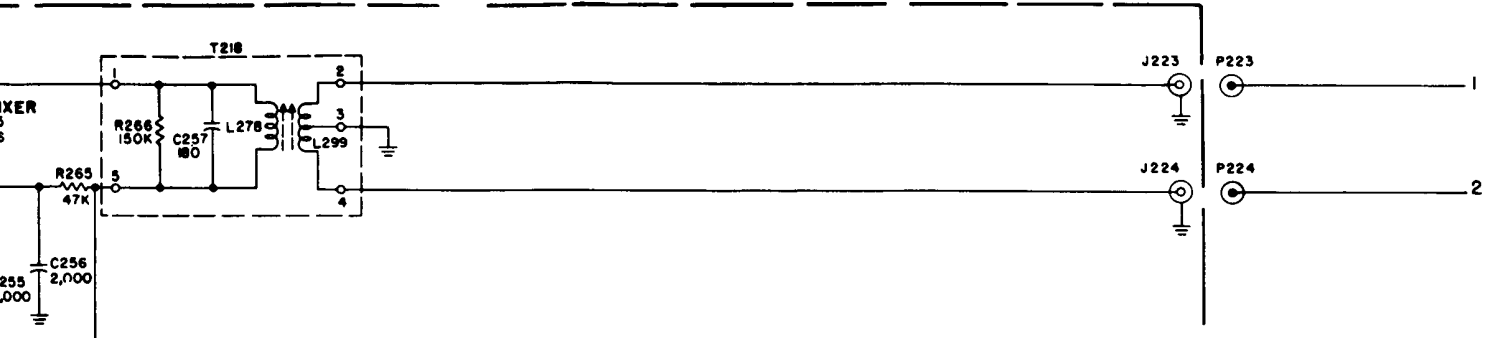

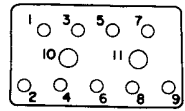

P116

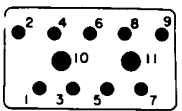

J423

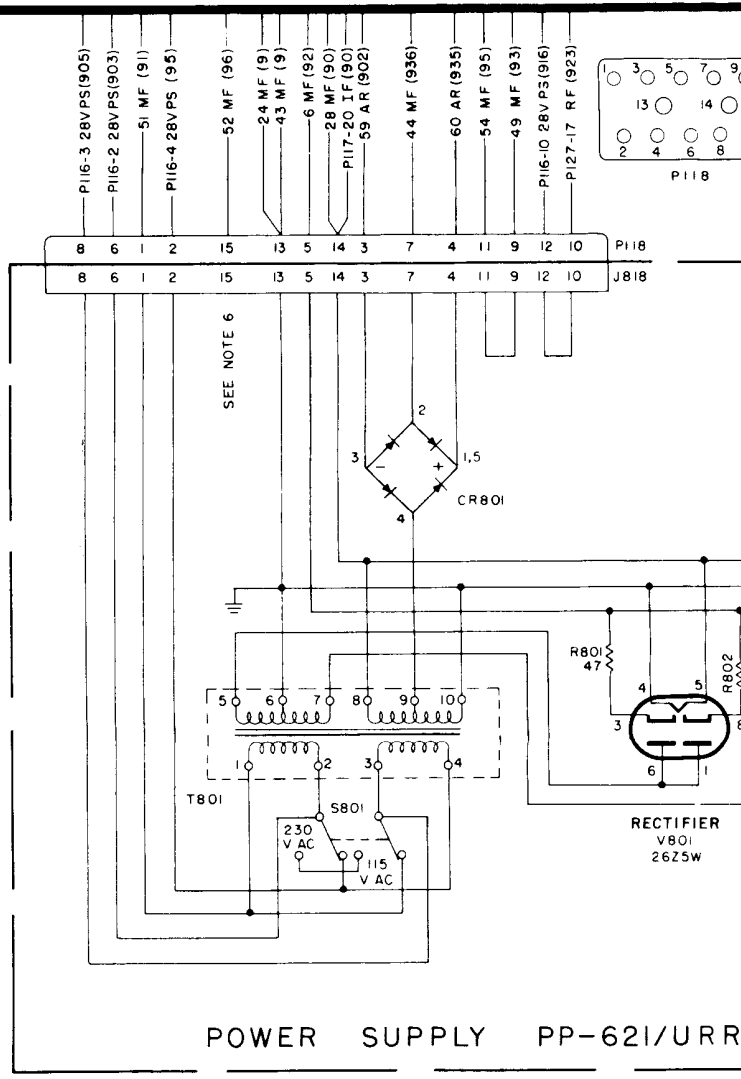
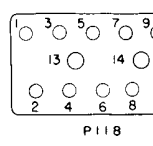
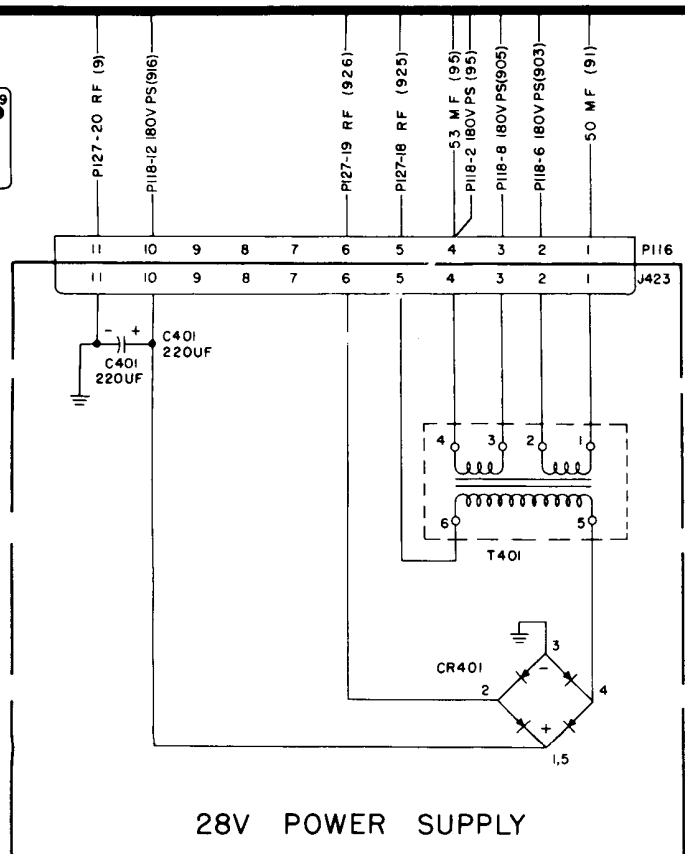

POWER SUPPLY PP-621/URR

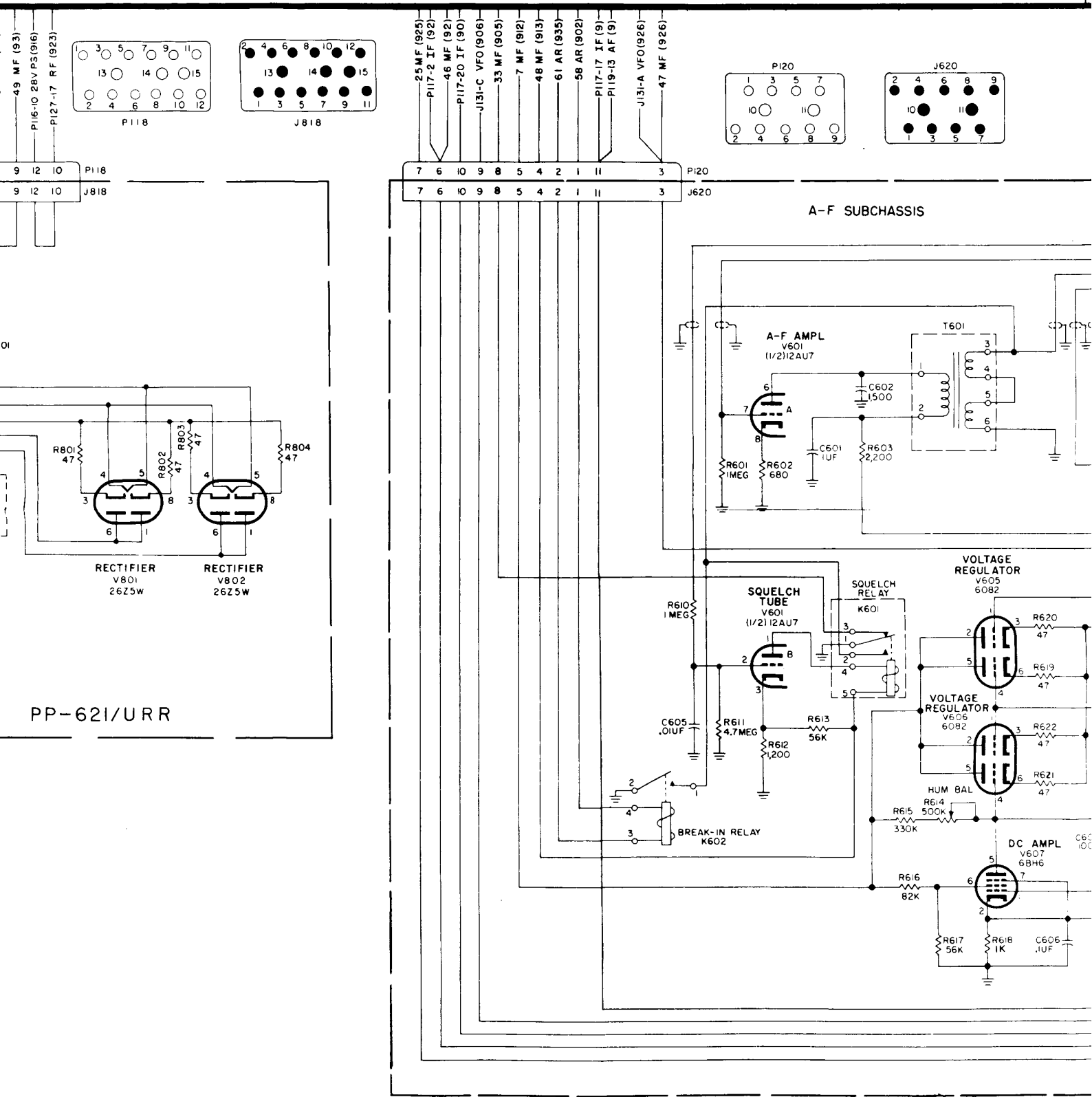
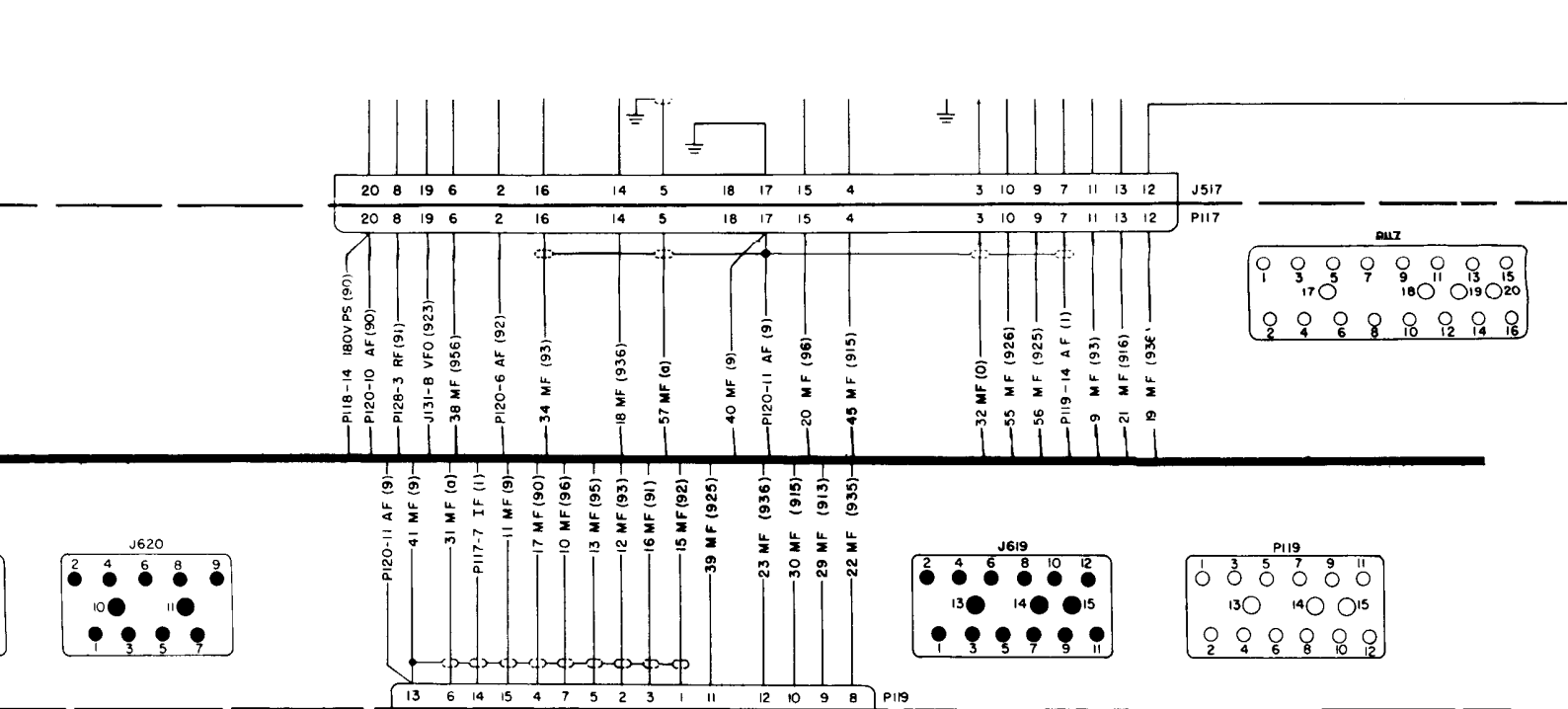
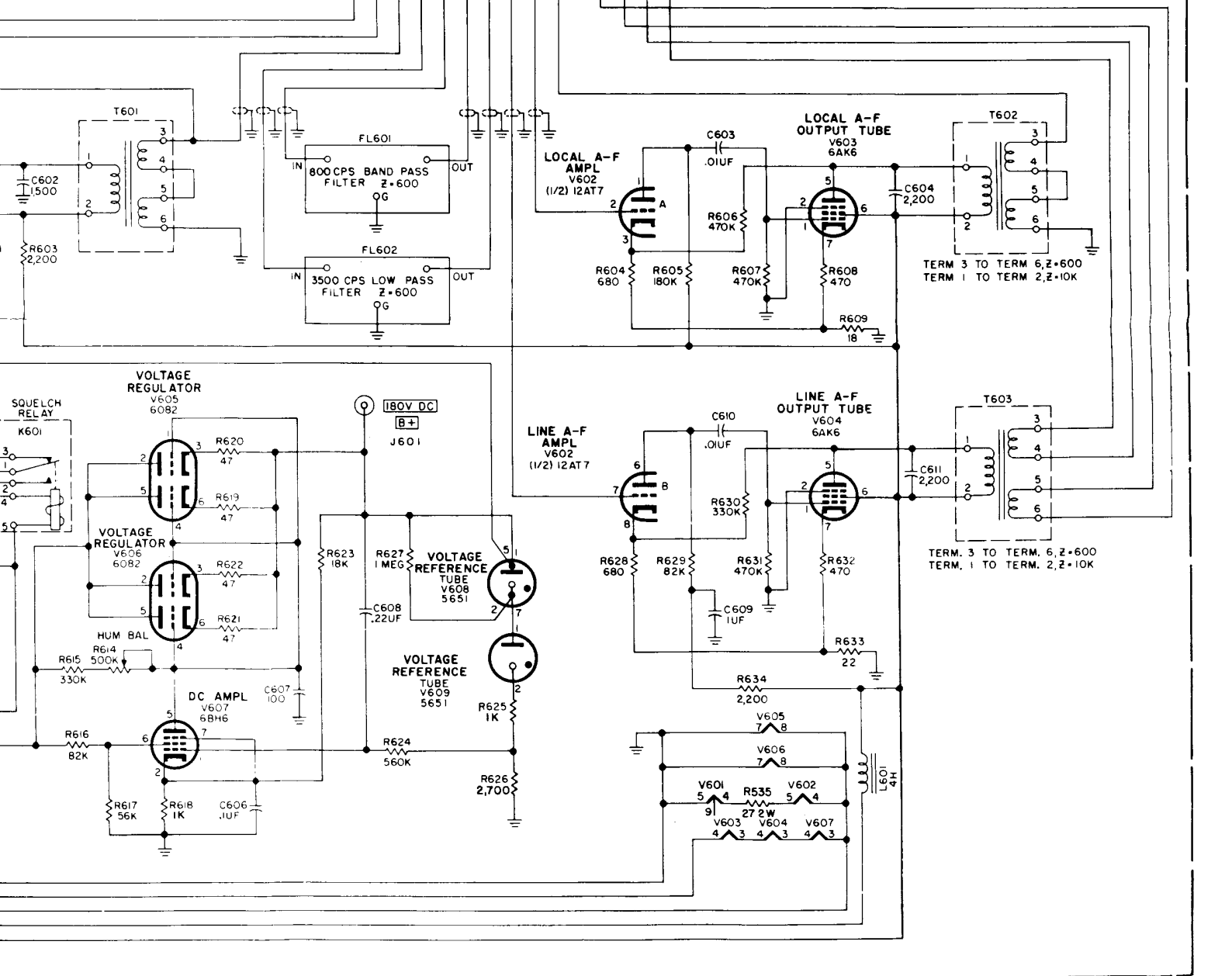

Figure 88. Subchassis and interconnection diagram—Continued.



SUBCHASSIS



Continued.

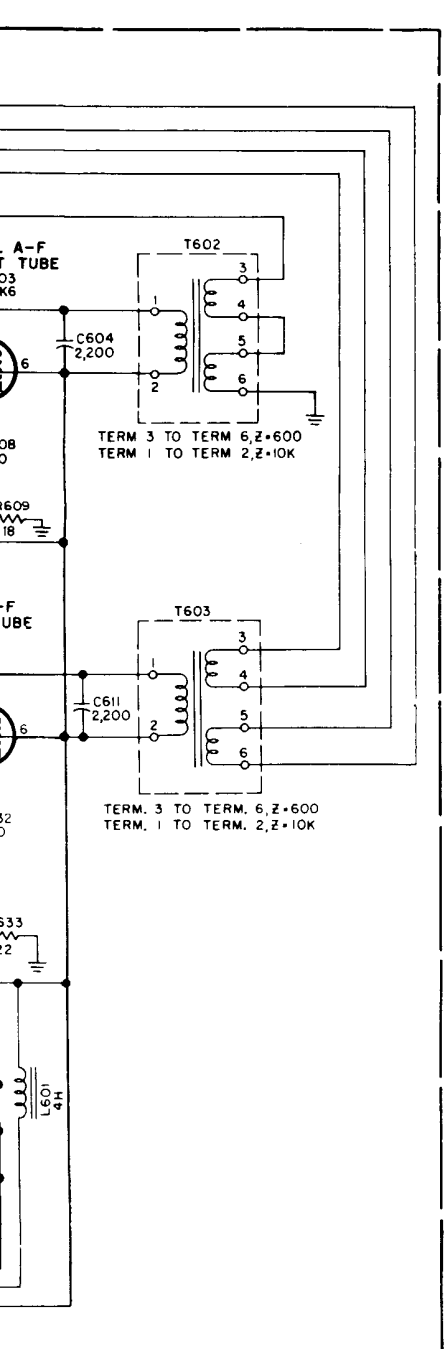
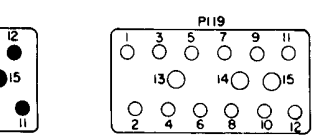
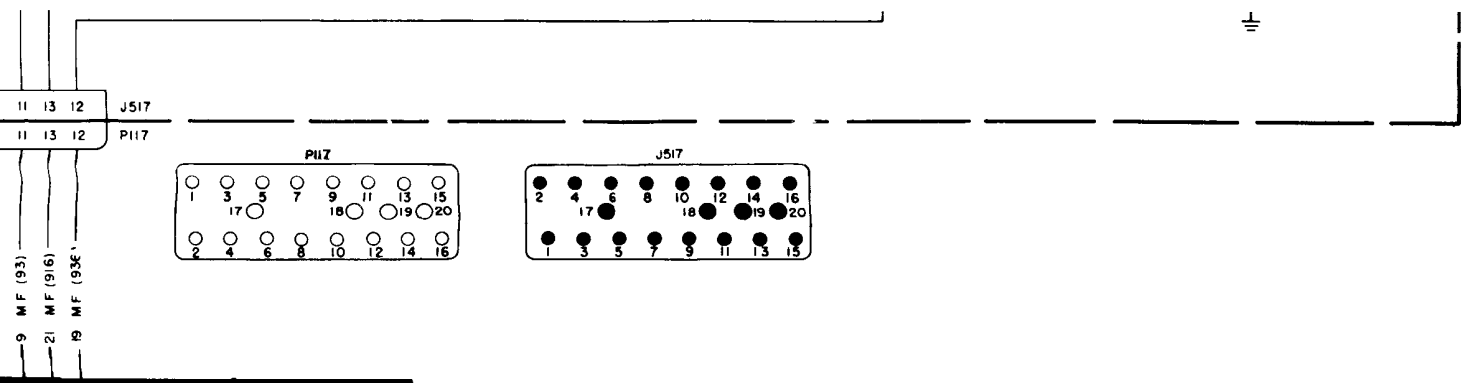

NOTES:

- 1 UNLESS OTHERWISE SHOWN, RESISTORS ARE IN OHMS, CAPACITORS ARE IN UUF.
- 2 ALL SWITCHES ON THIS DIAGRAM ARE SHOWN AS VIEWED FROM THE END OPPOSITE THE KNOB OR DRIVEN END. S102, S201, AND S203 ARE SHOWN IN POSITION FOR OPERATION IN THE 15-500 KC RANGE. S201 AND S205 ARE SHOWN IN POSITION FOR OPERATION IN THE BAND OF 15 TO 27 KILOCYCLES.
- 3 IN I-F CHASSIS STAMPED "MOD", FOLLOWED BY A NUMBER, R558 IS 1.2 MEG.
- 4 [] INDICATES EQUIPMENT MARKING.
- 5 R561 SELECTED AT TEST-RANGE OF VALUES OF 560 TO 5,600 OHMS.
- 6 NOT USED IN RADIO RECEIVER R-389/UUR.
- 7 ALL RELAY AND OVEN SWITCH CONTACTS ARE SHOWN IN THEIR NORMAL POSITIONS WITH POWER "OFF."
- 8 ABBREVIATIONS:
 AR = ANTENNA RELAY
 AF = A-F SUBCHASSIS
 IF = I-F SUBCHASSIS
 MF = MAIN FRAME
 28VPS = BAND SWITCHING MOTOR POWER SUPPLY
 180VPS = PP-621/UUR
 RF = RF SUBCHASSIS
- 9 WIRE COLOR CODE, APPLIES ONLY TO CABLING AND CONNECTORS
 FIRST NO. = BODY COLOR
 SECOND NO. = WIDE TRACER
 THIRD NO. = NARROW TRACER
 1 = BROWN
 2 = RED
 3 = ORANGE
 4 = YELLOW
 5 = GREEN
 6 = BLUE
 9 = WHITE
 0 = BLACK
 NO CODE NUMBER = BUS WIRE
 □ = TRANSPARENT
10. EXAMPLES OF THE CODING USED FOR THE INTERCONNECTING CABLE ON THIS DRAWING ARE AS FOLLOWS:

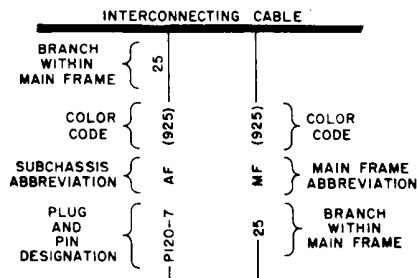

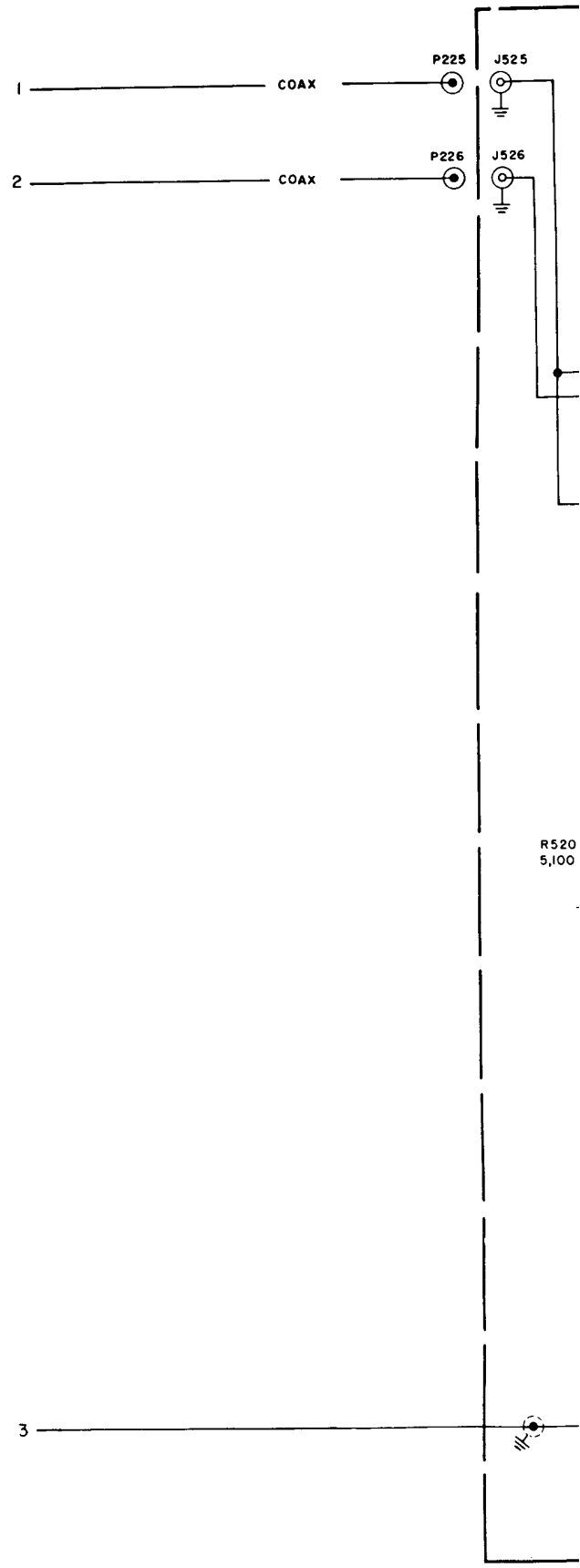

P225

P226

J525

J526

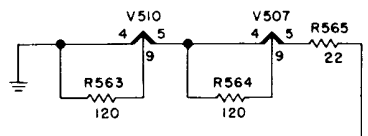
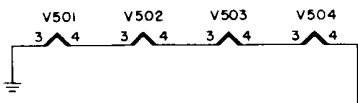
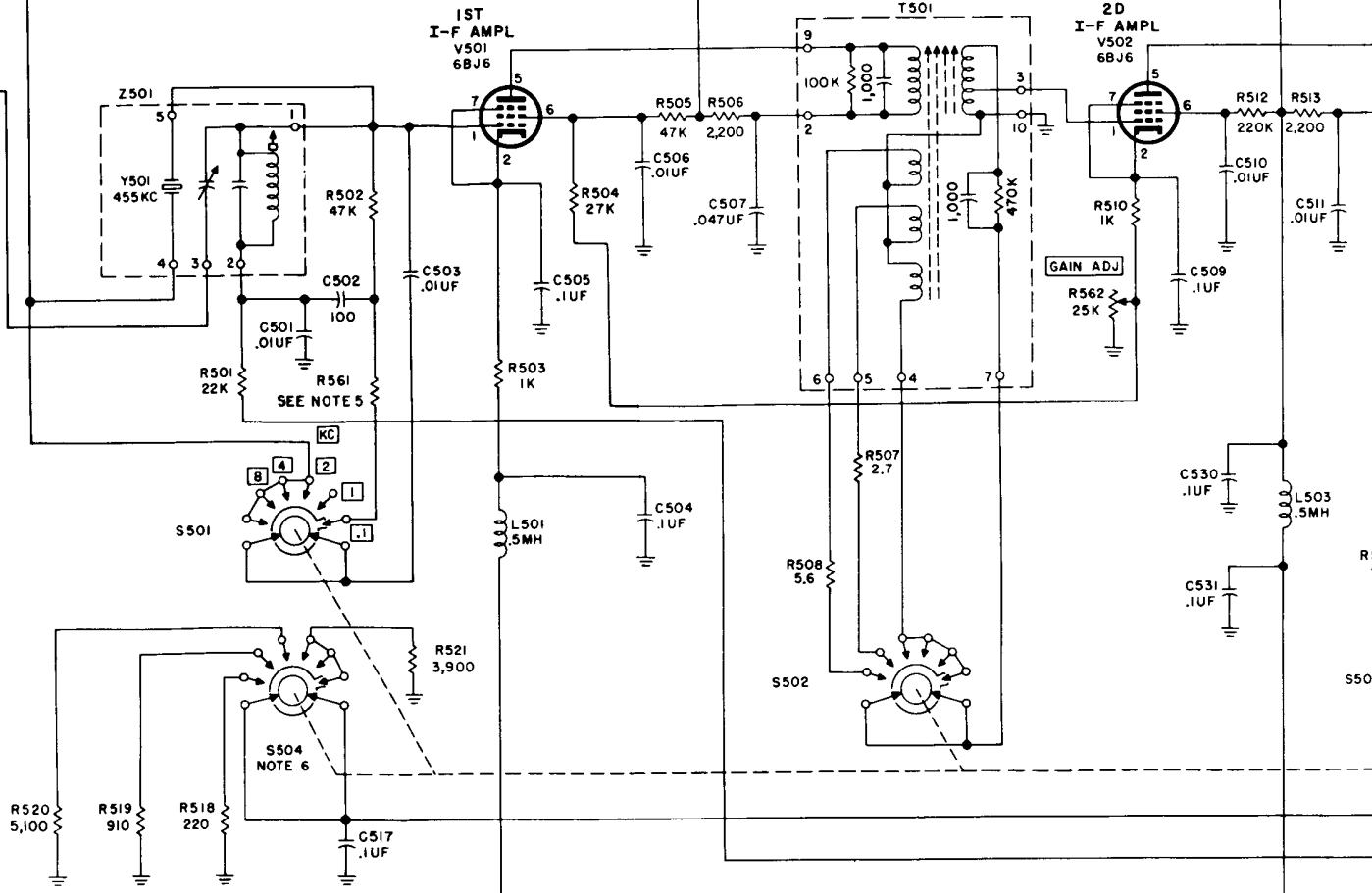

I-F SUBCHASSIS

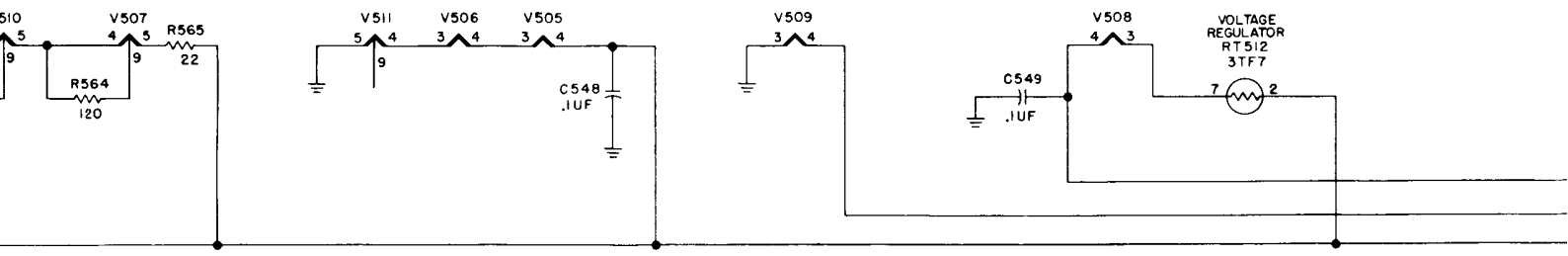
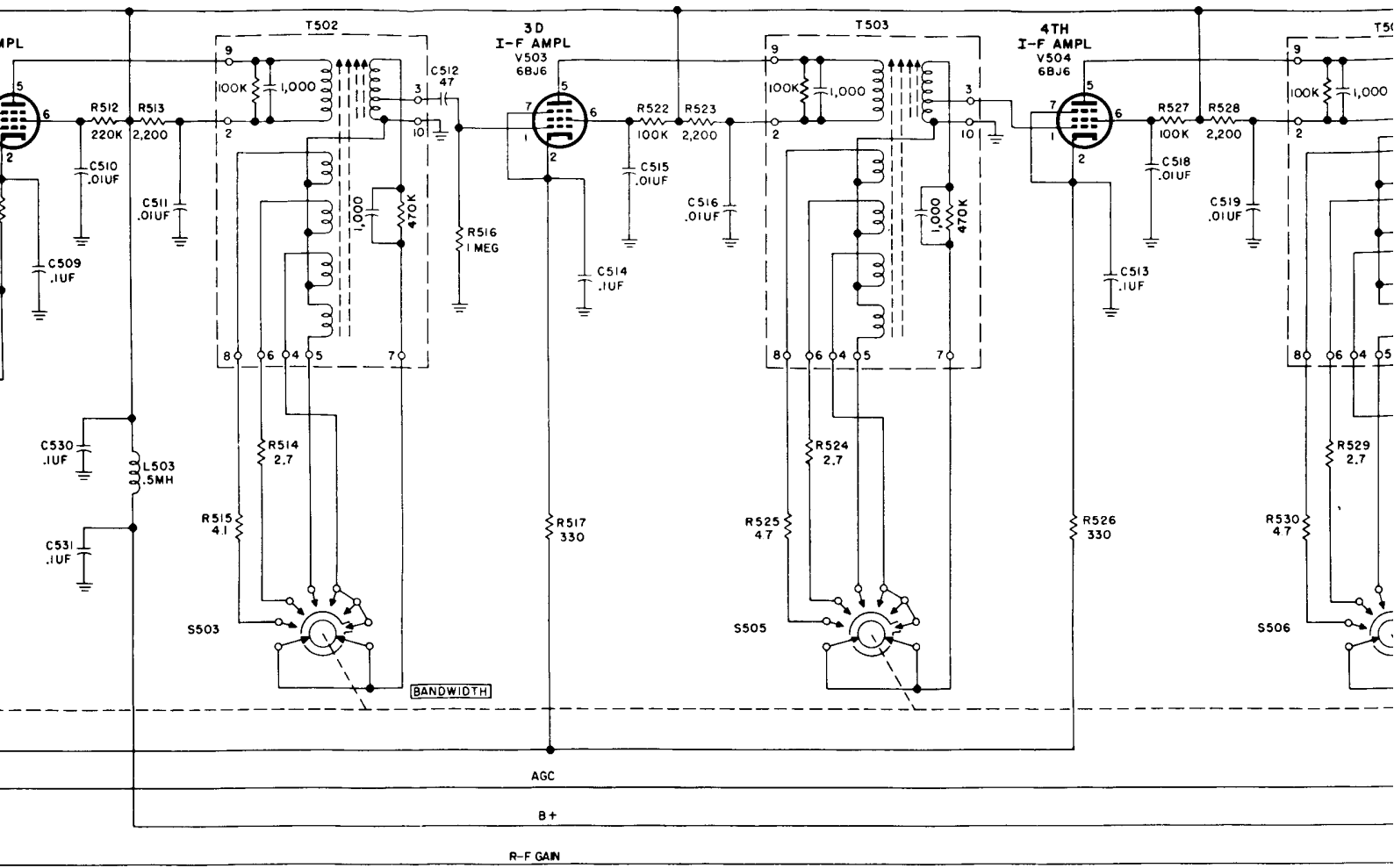

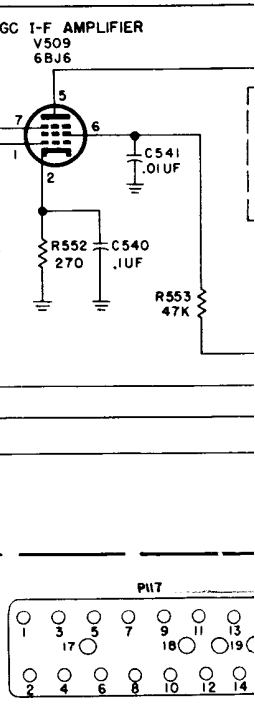
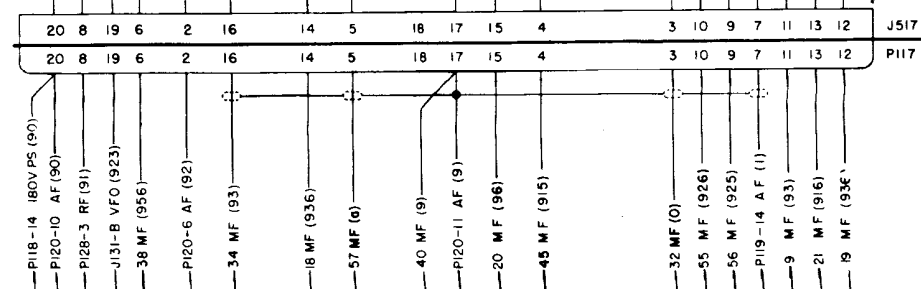
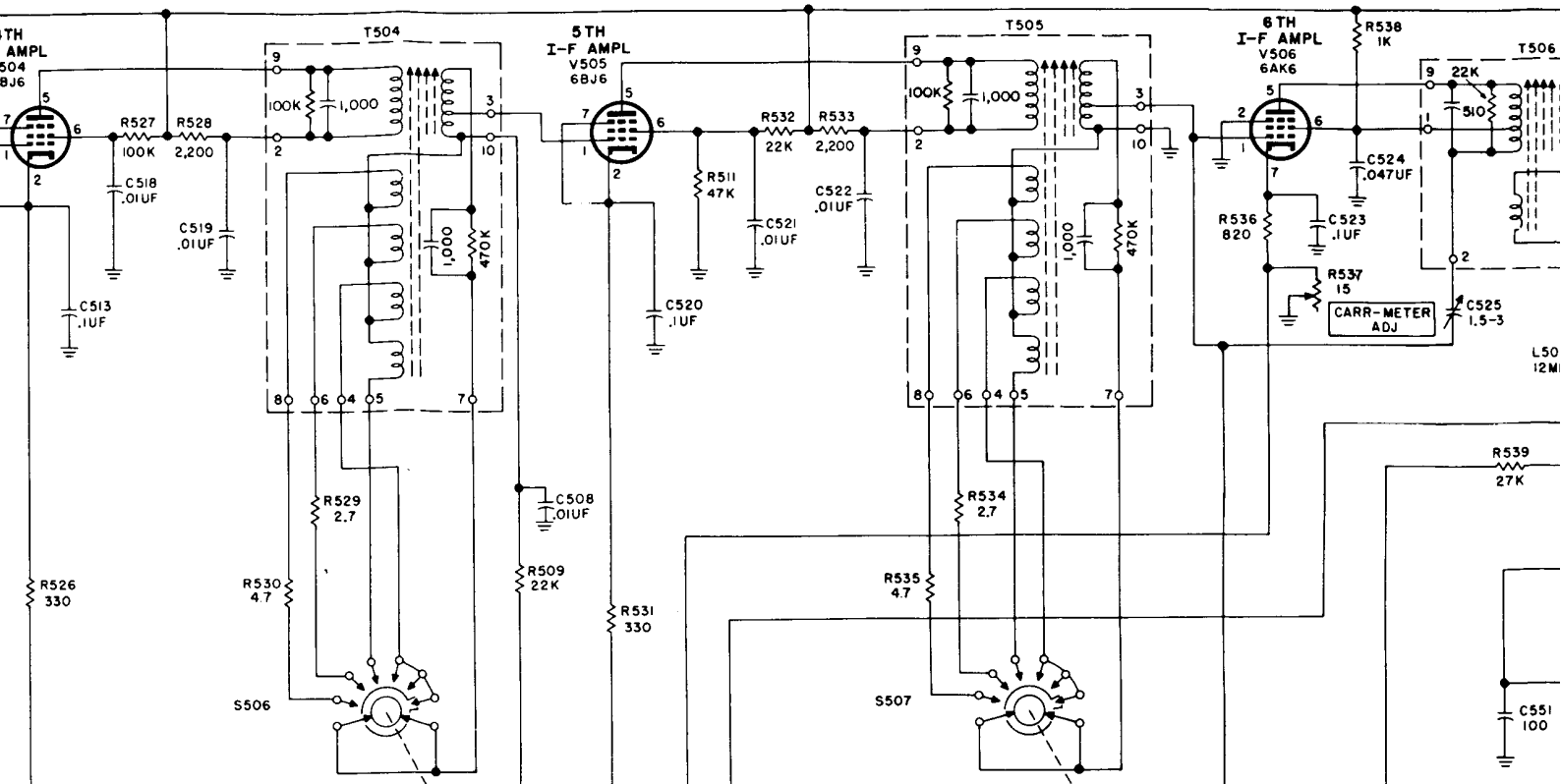

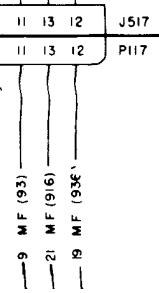
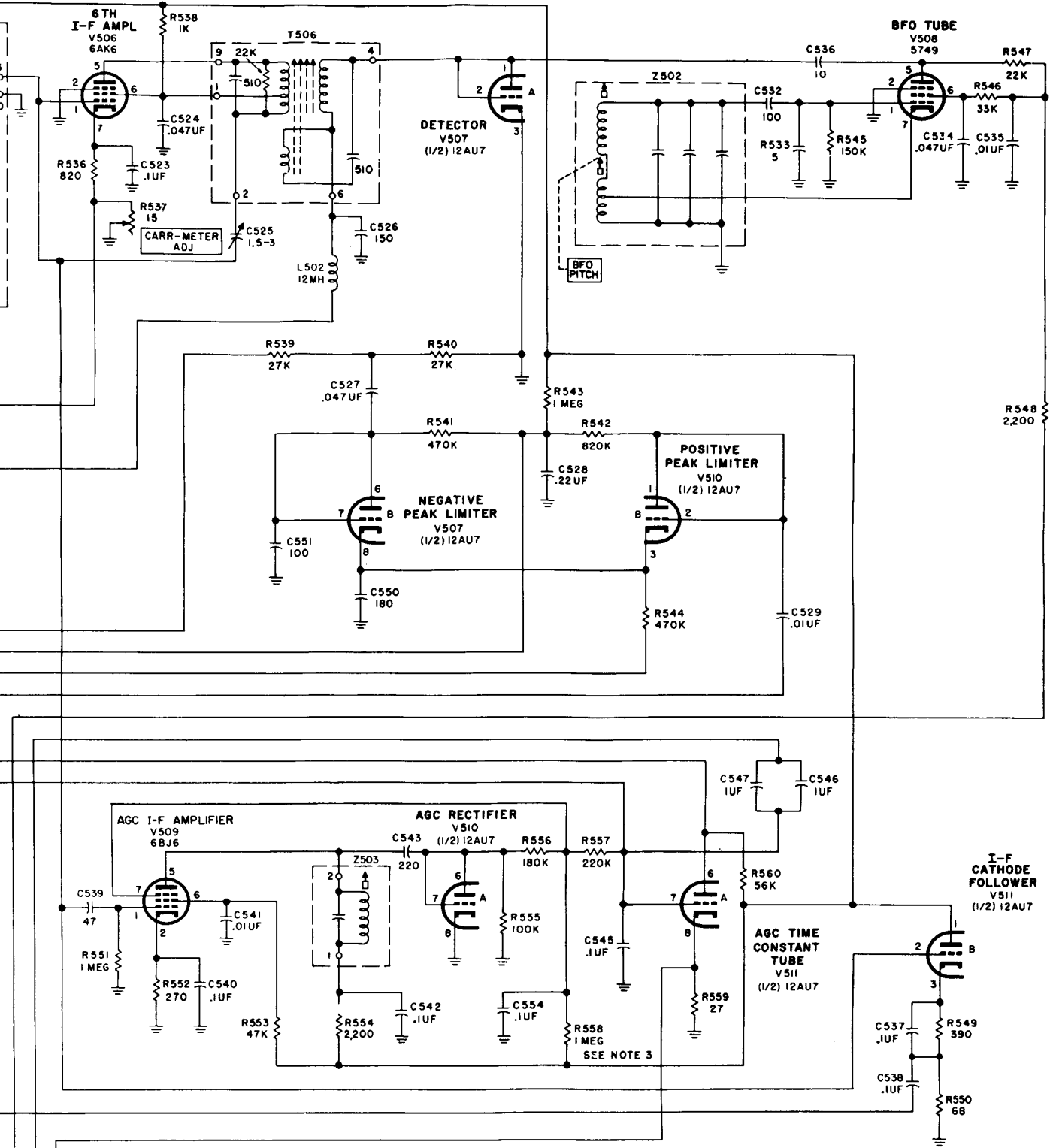

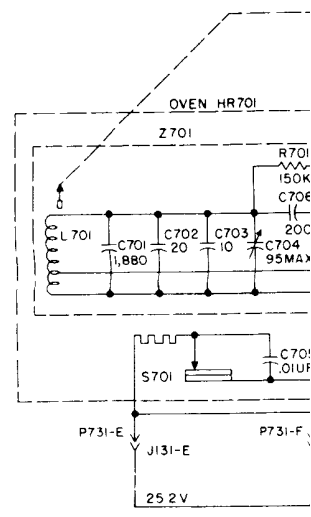
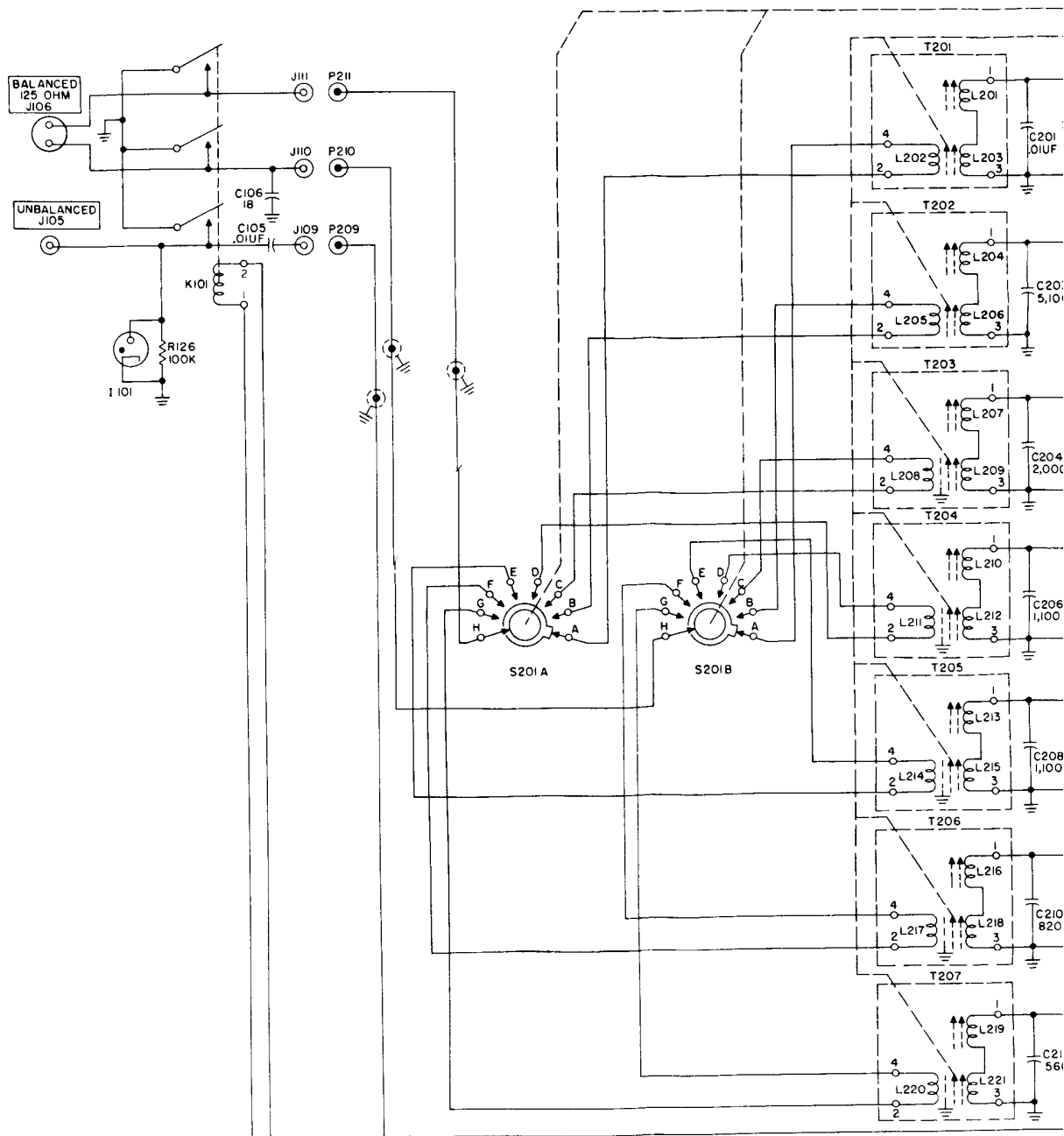

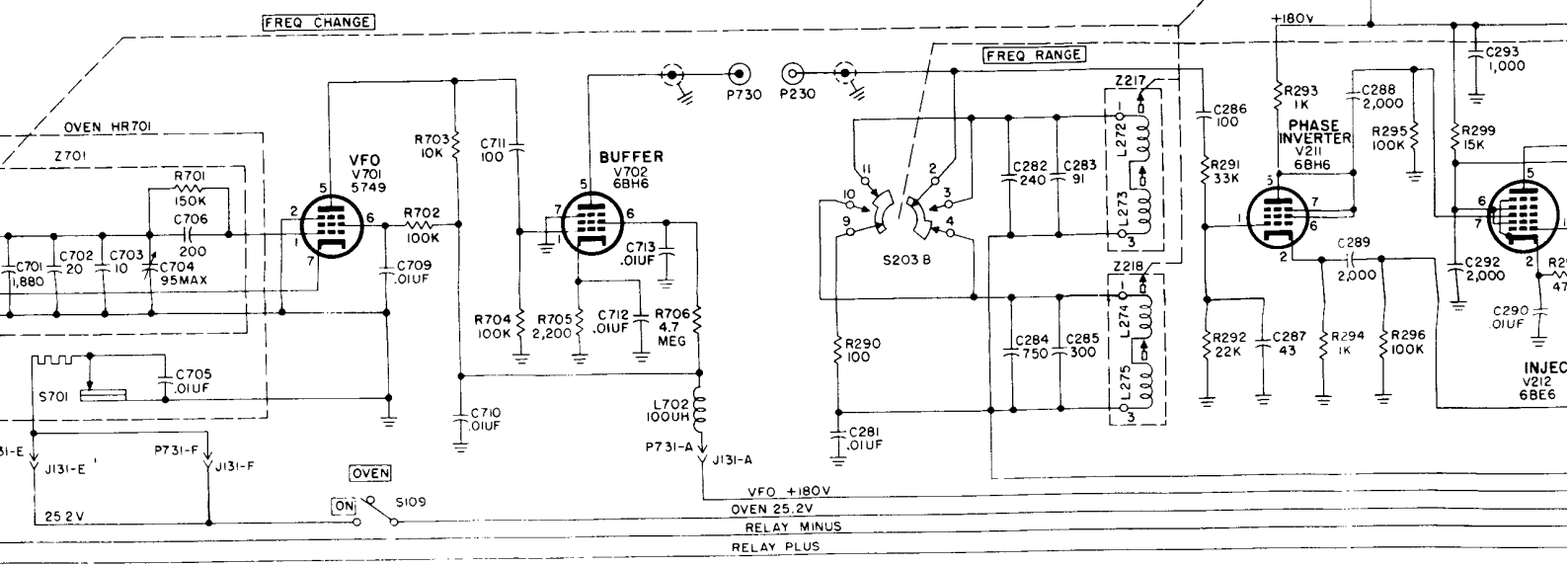
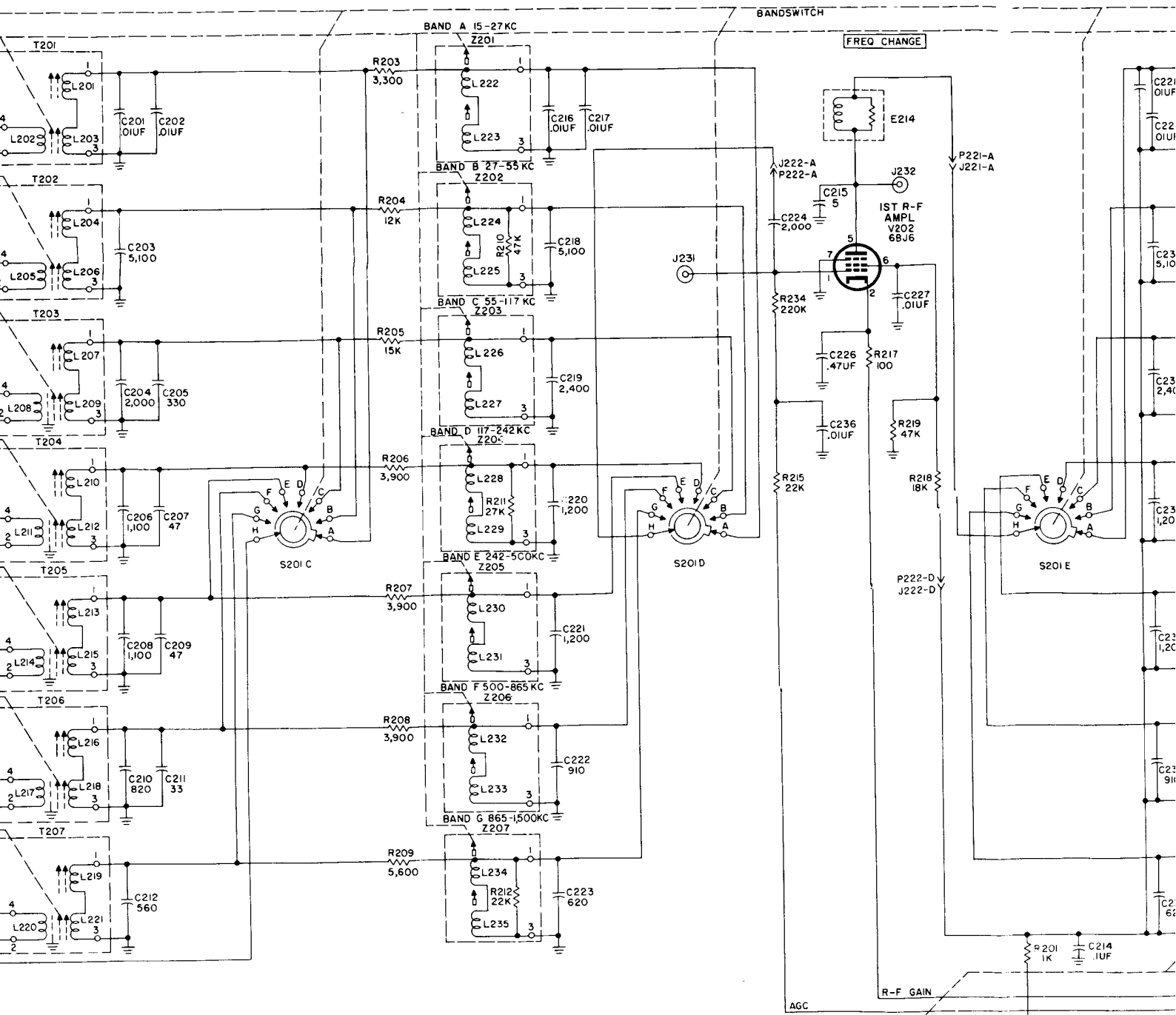

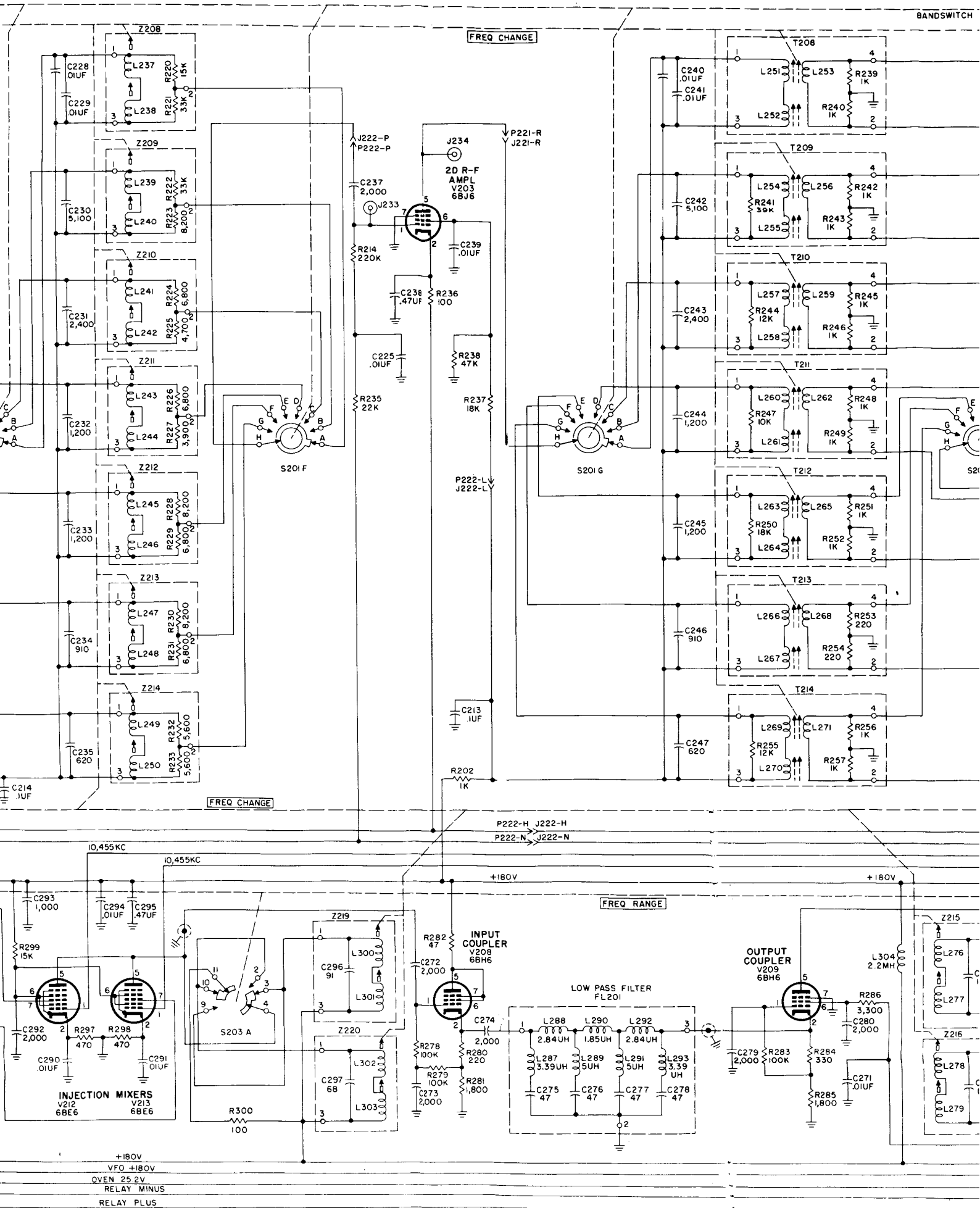
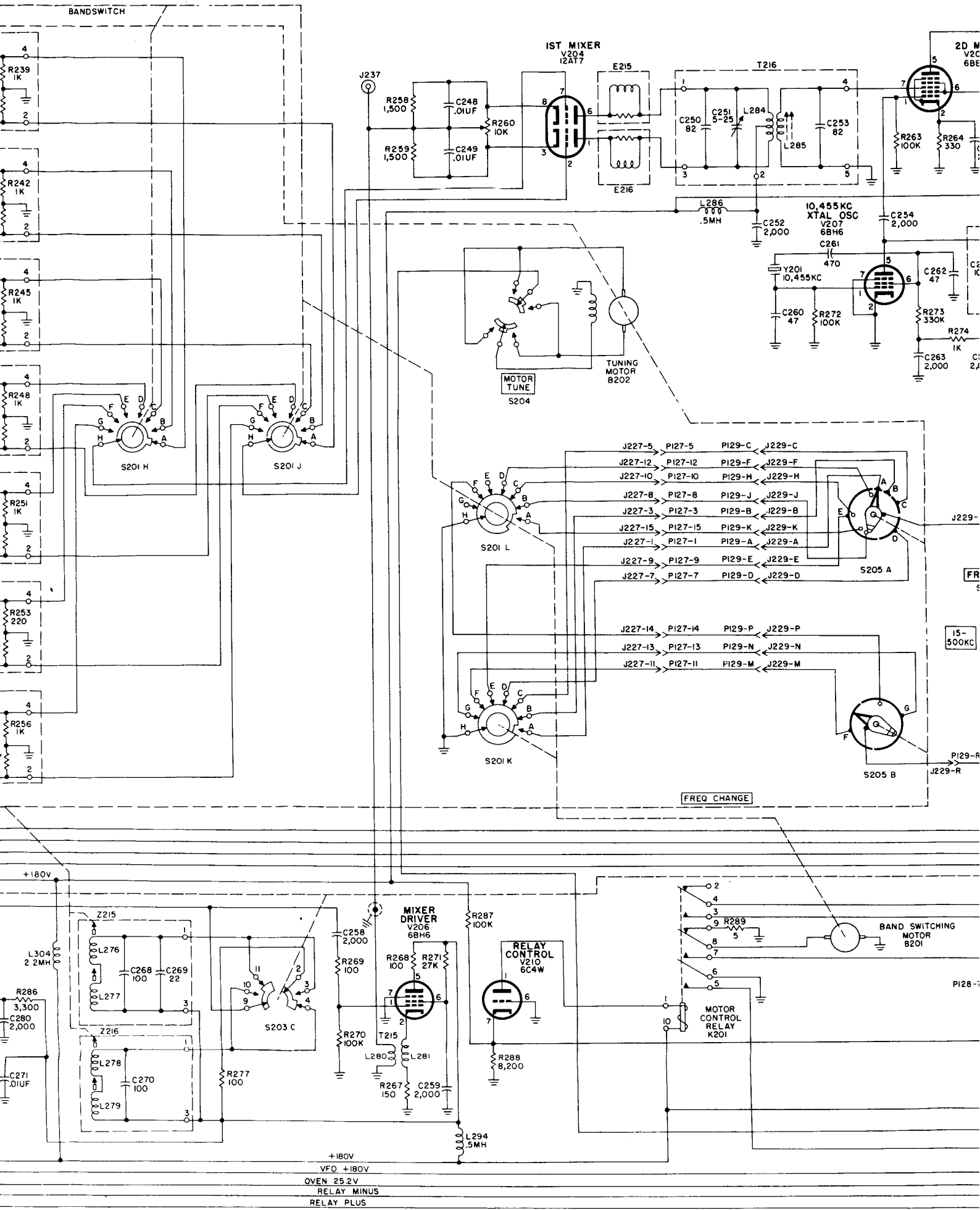

Figure 89. Radio Receiver R-389/URR, schematic diagram.



BANDSWITCH

IST MIXER
V204
12AT7

T216

MOTOR TUNE
S204

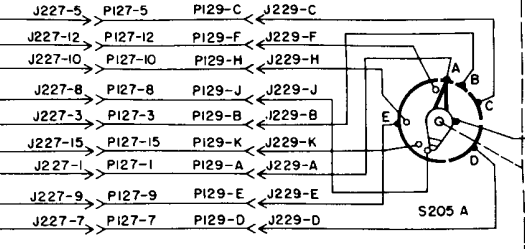

FREQ CHANGE

MIXER DRIVER
V206
6BH6

RELAY CONTROL
V210
6C4W

BAND SWITCHING MOTOR
B201

MOTOR CONTROL RELAY
K201

+180V
VFO +180V
OVEN 25.2V
RELAY MINUS
RELAY PLUS

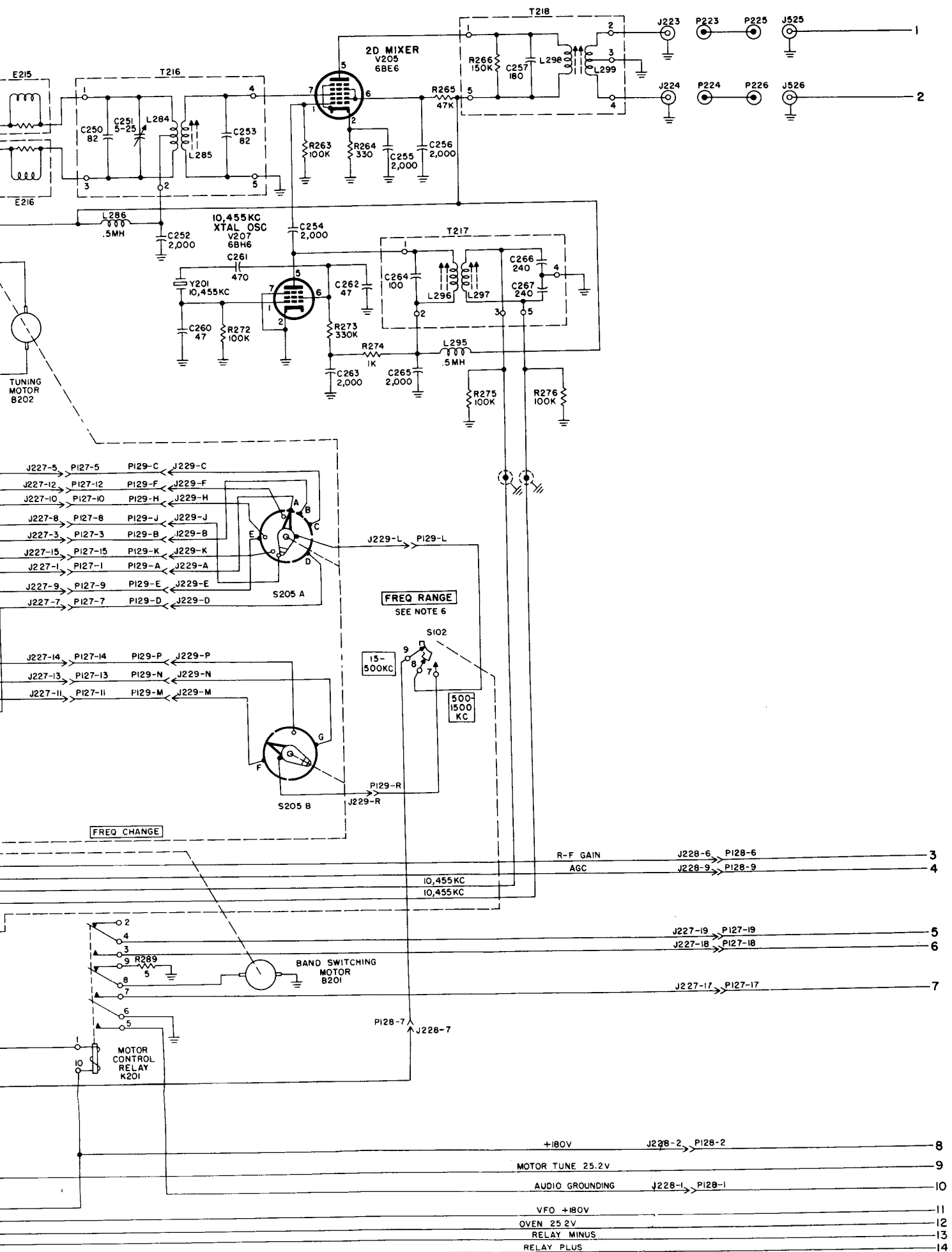

1 _____

2 _____

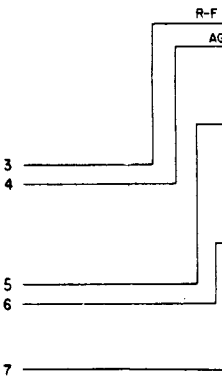

8 _____

9 _____

10 _____

11 _____

12 _____

13 _____

14 _____

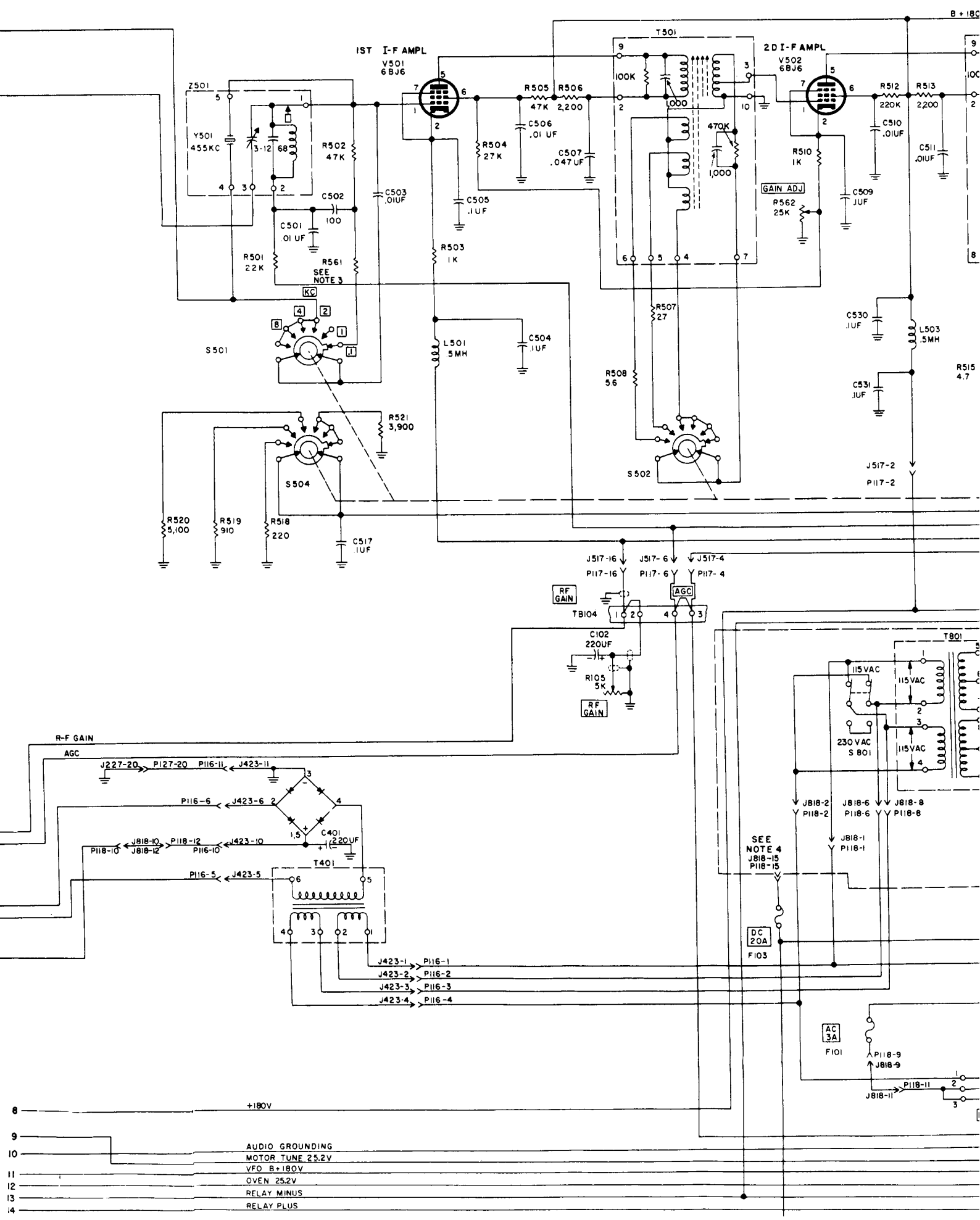

1ST I-F AMPL
V501
6BJ6

2ND I-F AMPL
V502
6BJ6

SEE NOTE 3

GAIN ADJ
R562
25K

SEE NOTE 4
J818-15
P118-13

- 8 +180V
- 9 AUDIO GROUNDING
- 10 MOTOR TUNE 25.2V
- 11 VFO B+180V
- 12 OVEN 25.2V
- 13 RELAY MINUS
- 14 RELAY PLUS

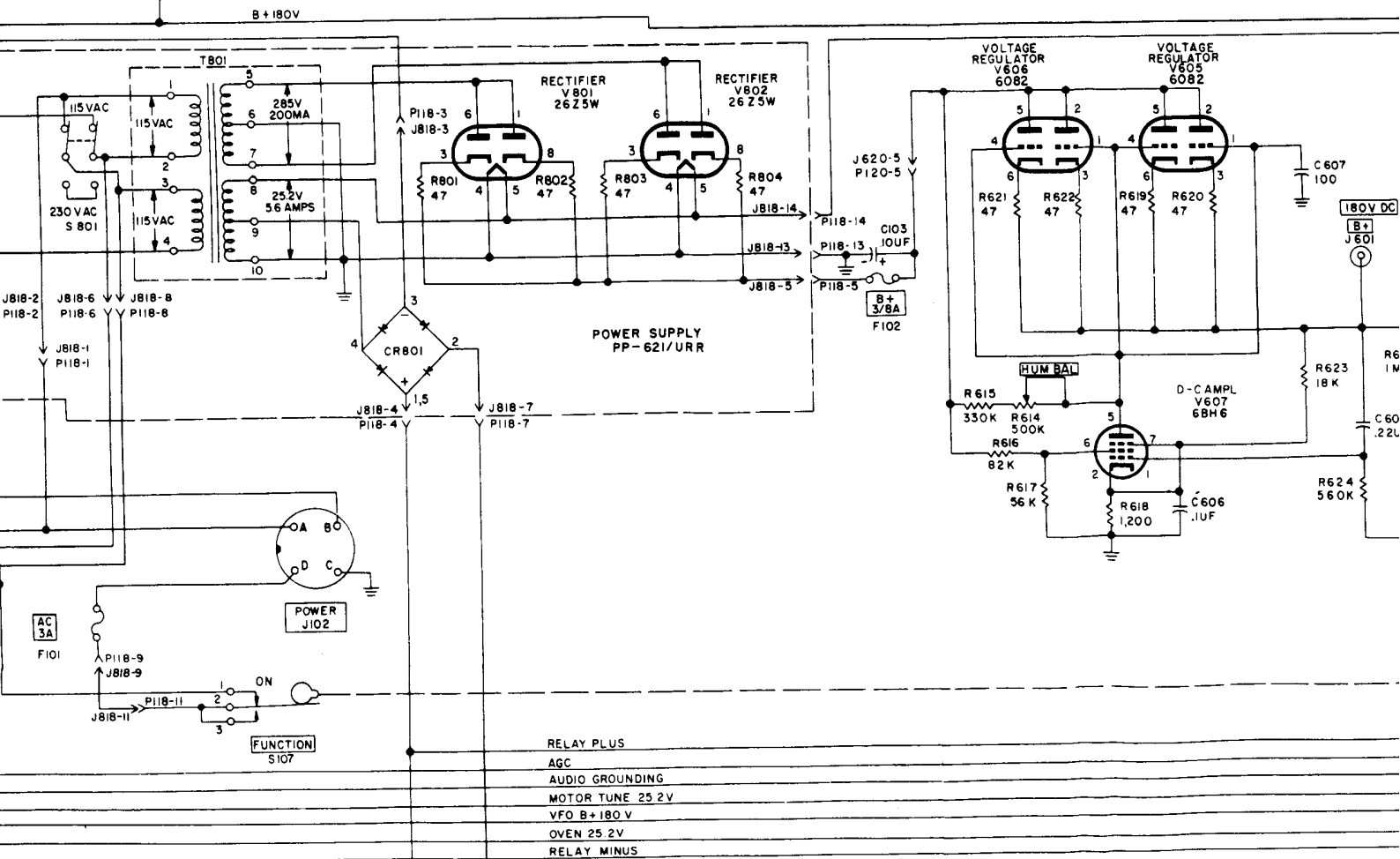
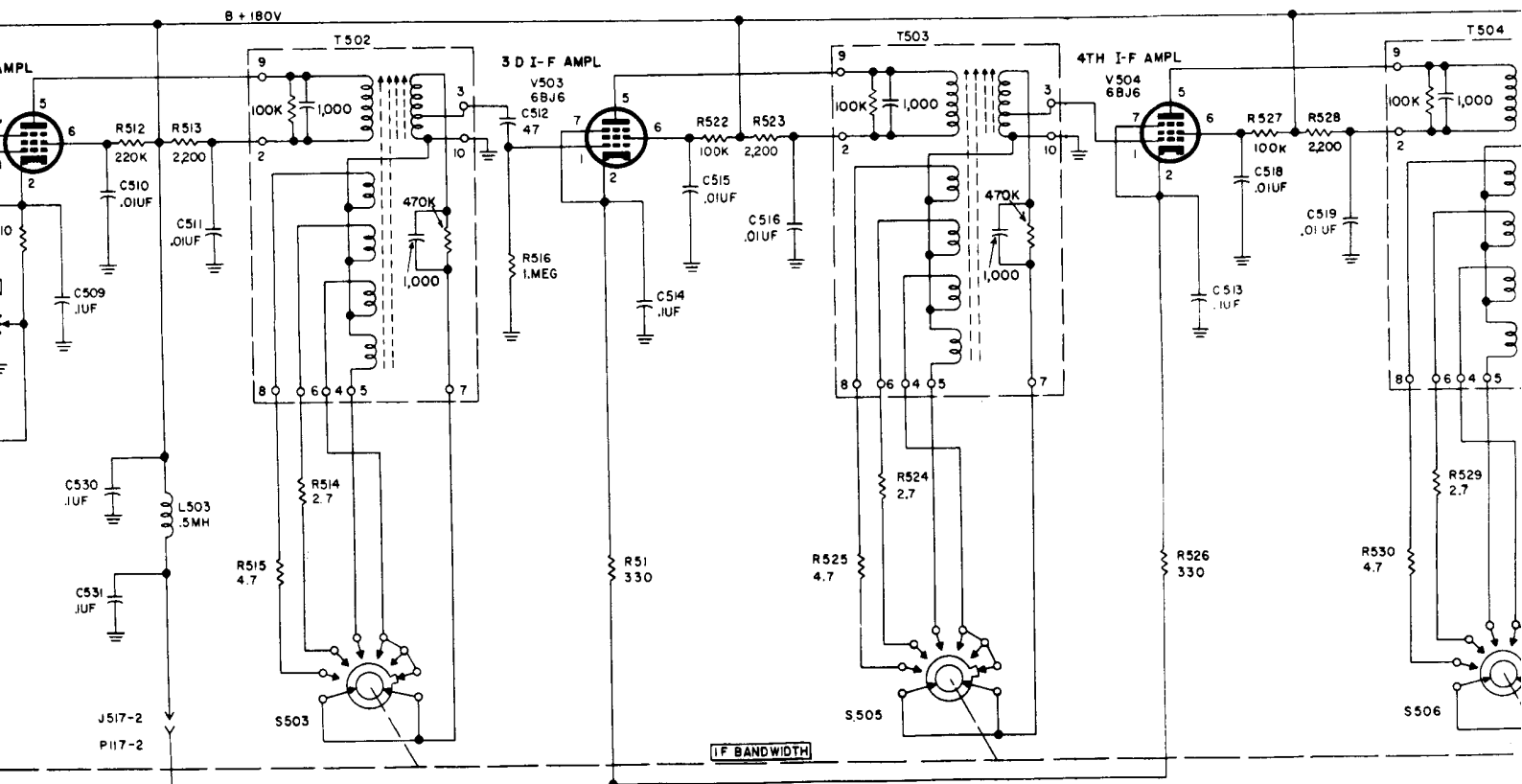

- RELAY PLUS
- AGC
- AUDIO GROUNDING
- MOTOR TUNE 25.2V
- VFO B+ 180V
- OVEN 25.2V
- RELAY MINUS

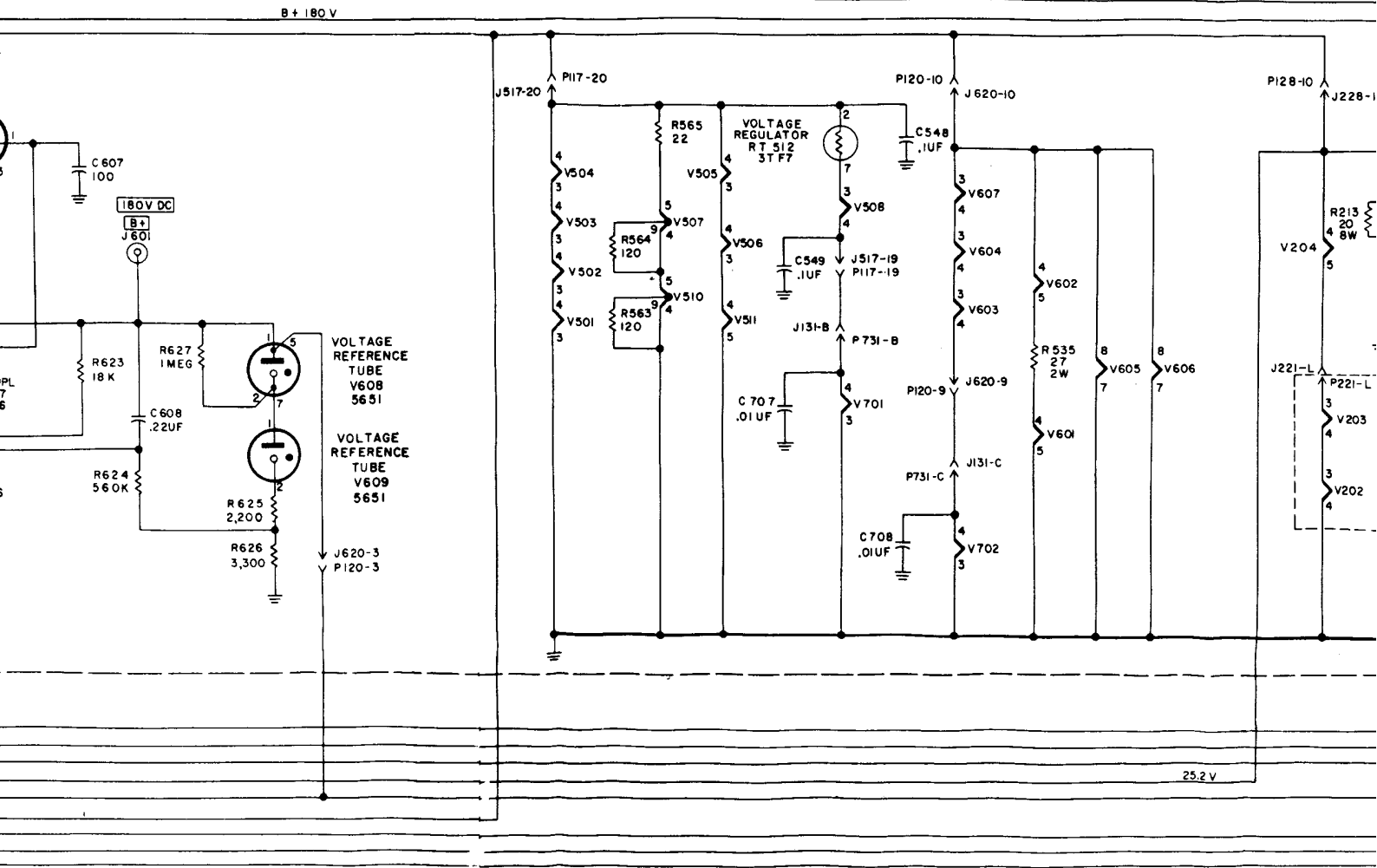
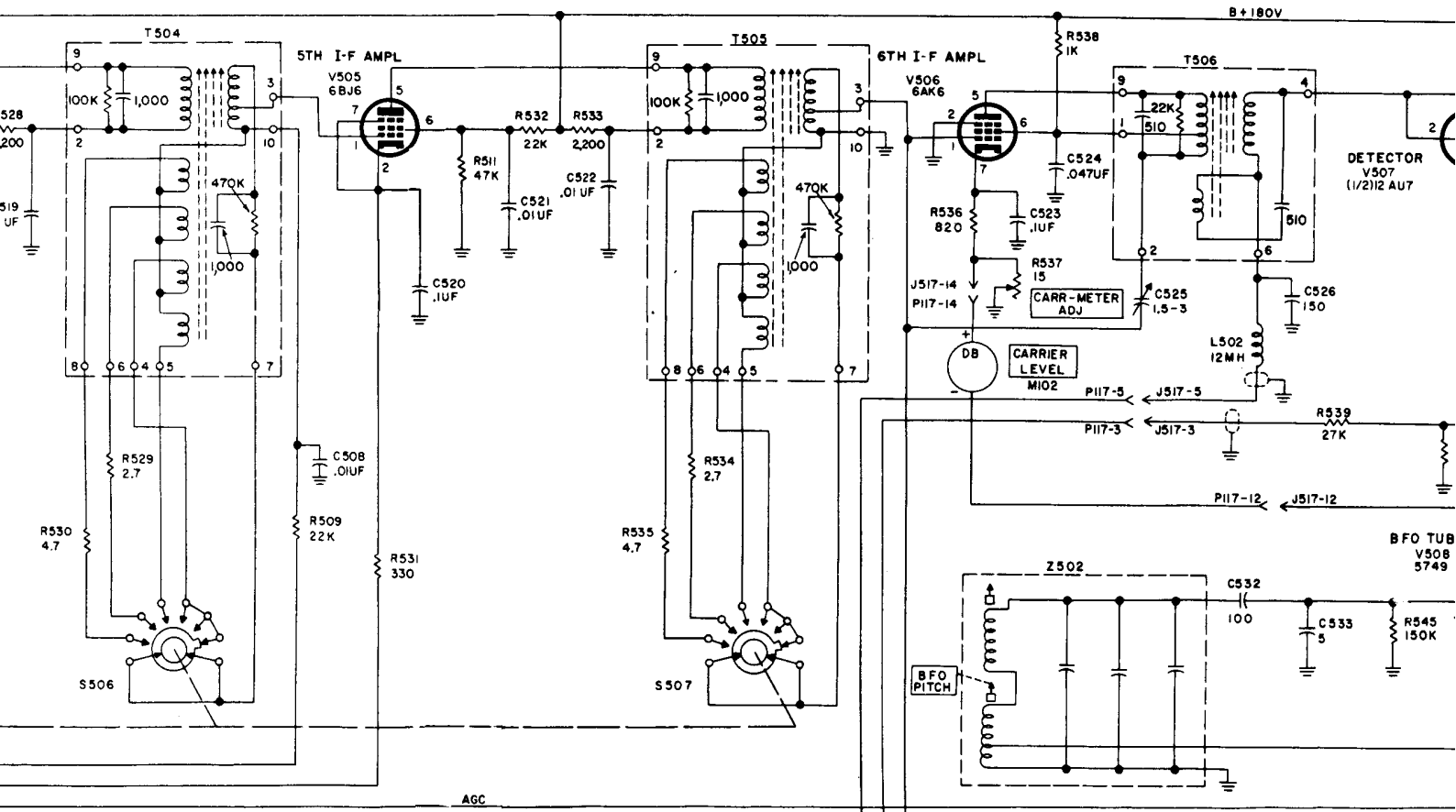

Figure 89. Radio Receiver R-389

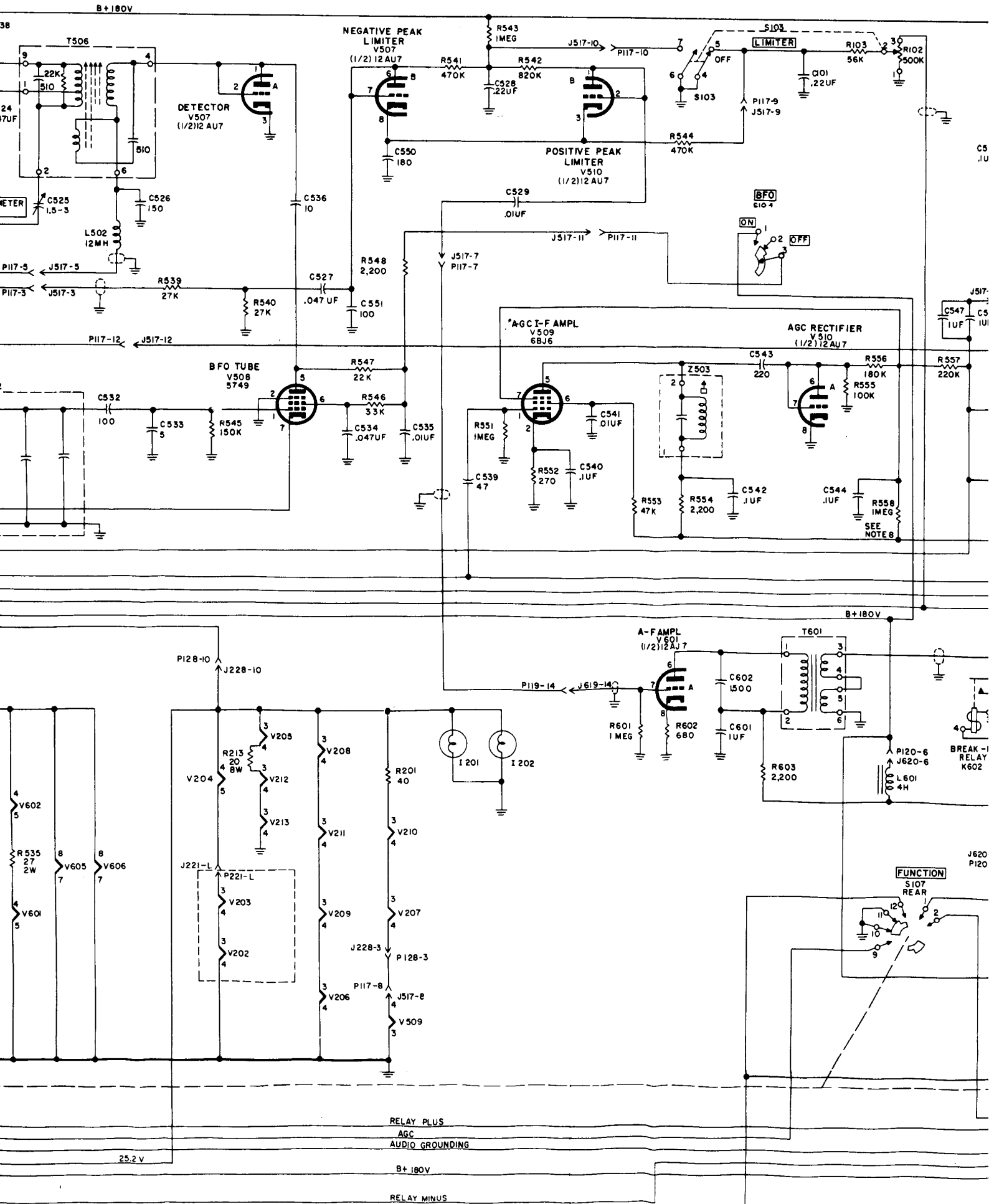
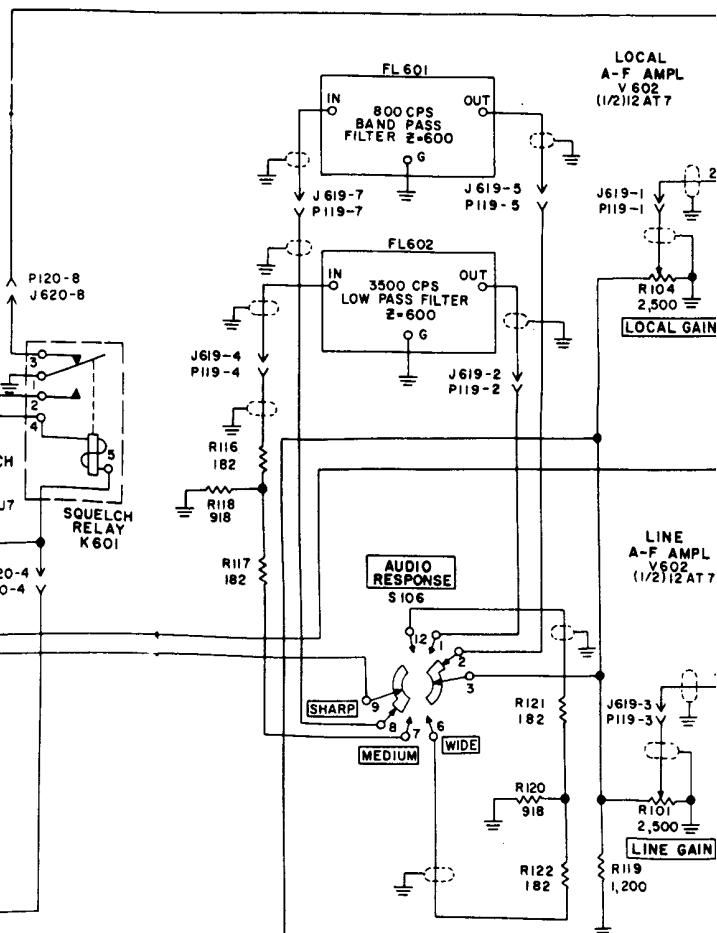
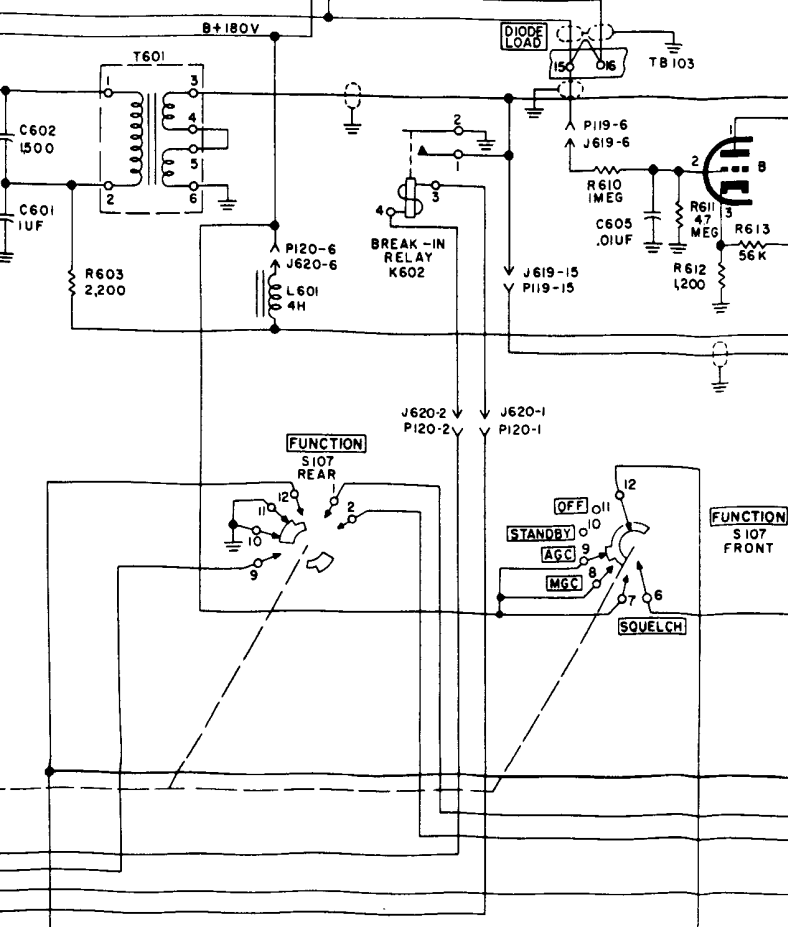
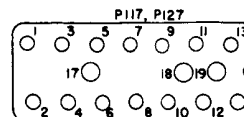
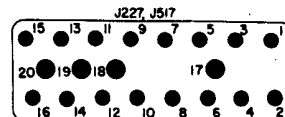
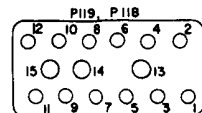
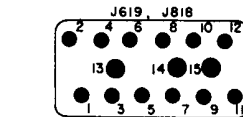
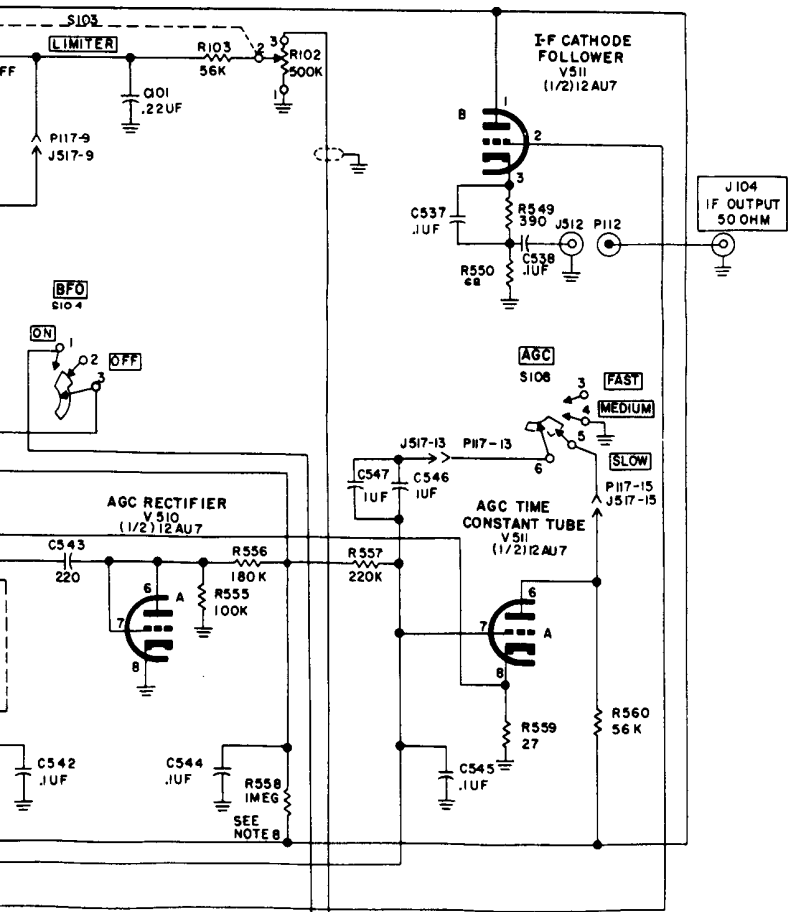
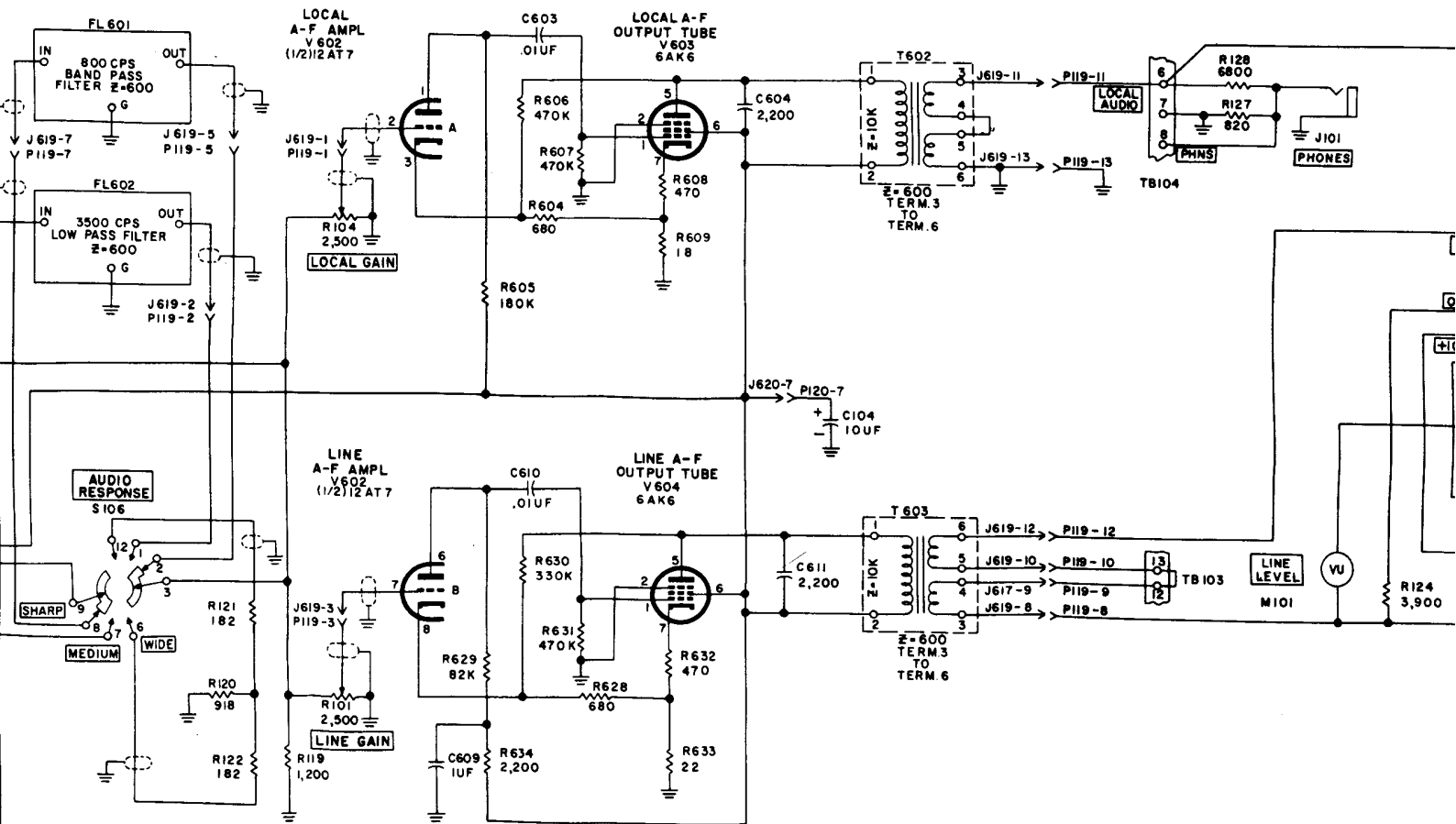
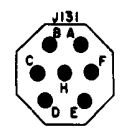
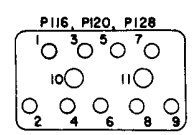
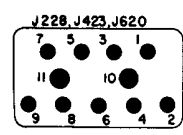
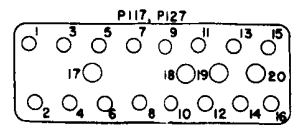
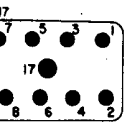
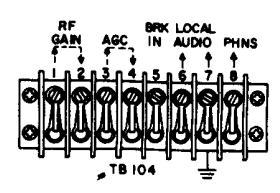
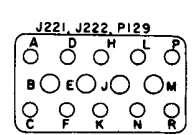
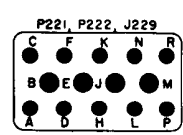
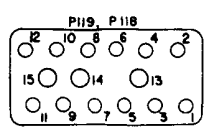
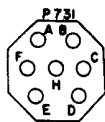
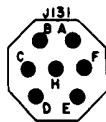
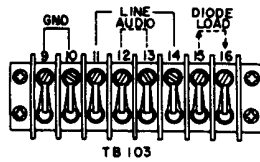
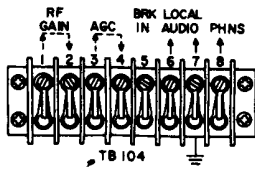
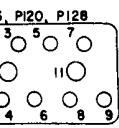
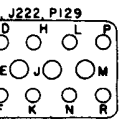

Figure 89. Radio Receiver R-389/URR, schematic diagram—Continued.







NOTES:

1. UNLESS OTHERWISE SHOWN: RESISTORS ARE IN OHMS, CAPACITORS ARE IN UUF, INDUCTORS ARE IN UH.
2. ALL SWITCHES ARE SHOWN ON THIS DIAGRAM, AS VIEWED FROM THE END OPPOSITE THE KNOB OR DRIVEN END. S102, S201, AND S203 SHOWN IN POSITION FOR OPERATION IN THE [15-300KC] RANGE. S201 AND S203 ARE SHOWN IN POSITION FOR OPERATION IN THE BAND OF 15 TO 27 KILOCYCLES.
3. R561 SELECTED AT TEST-RANGE OF VALUES 560 TO 5,600 OHMS.
4. NOT USED IN RADIO RECEIVER R-389/URR.
5. ALL RELAY AND OVEN SWITCH CONTACTS ARE SHOWN IN THEIR NORMAL POSITIONS WITH POWER OFF.
6. FREQ RANGE SWITCH IS COMPOSED OF TWO GANGED SWITCHES S102 AND S203.
7. INDICATES EQUIPMENT MARKING.
8. IN I-F SUBCHASSIS STAMPED "MOD", FOLLOWED BY A NUMBER, R558 IS 1.2 MEG.

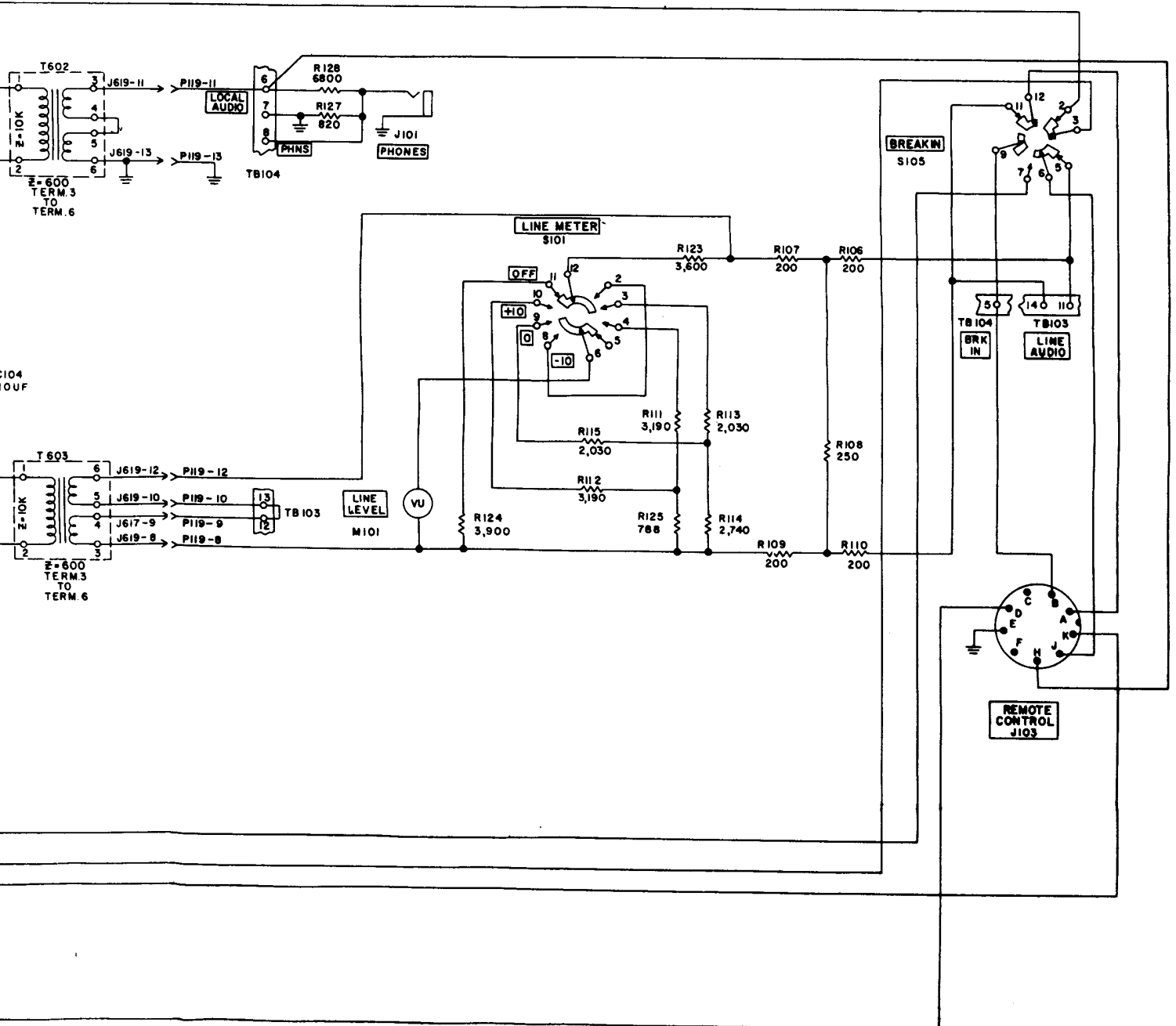

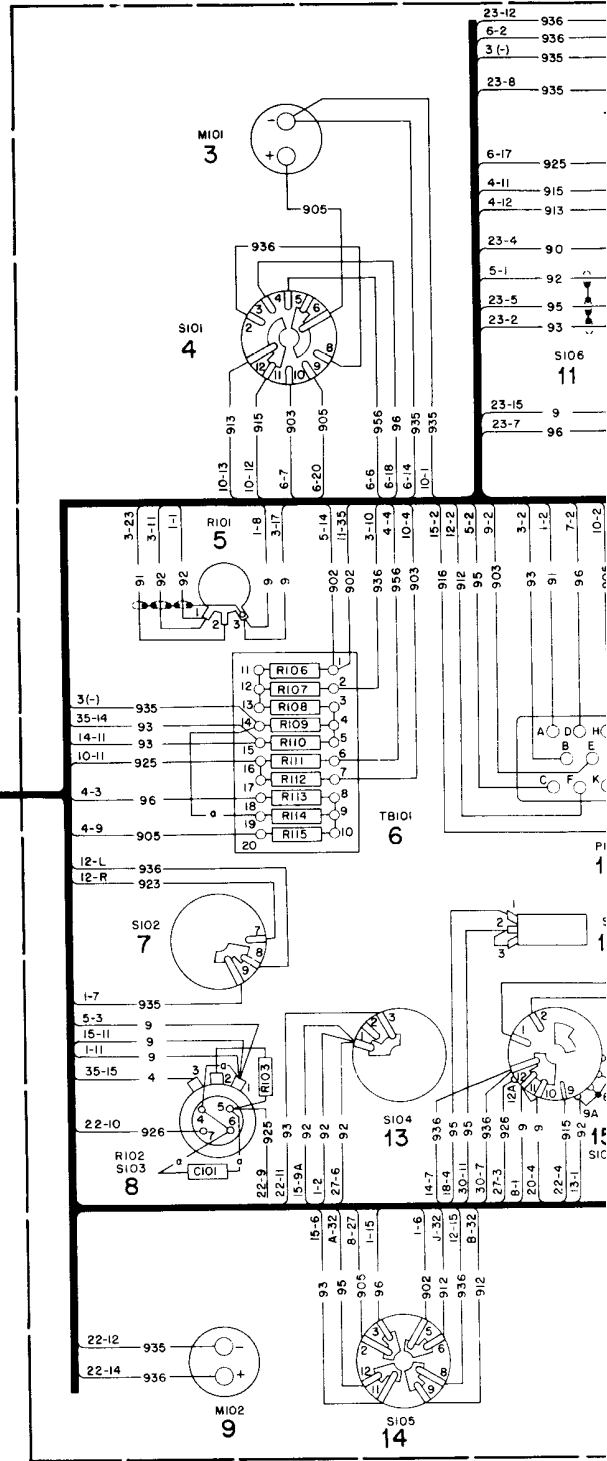
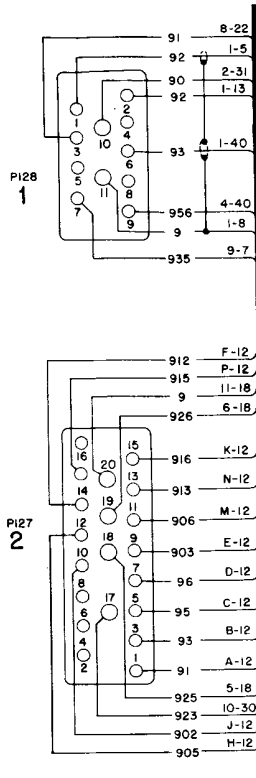

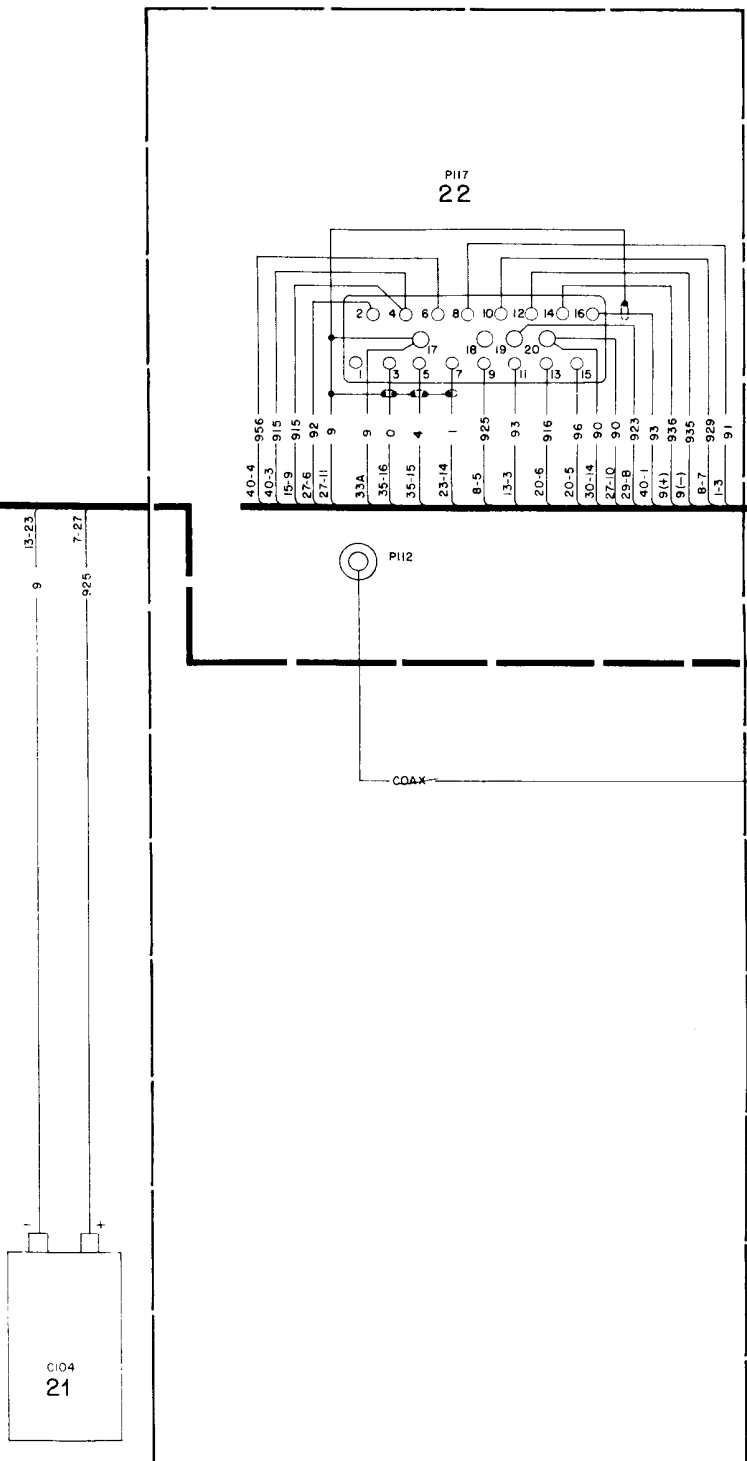
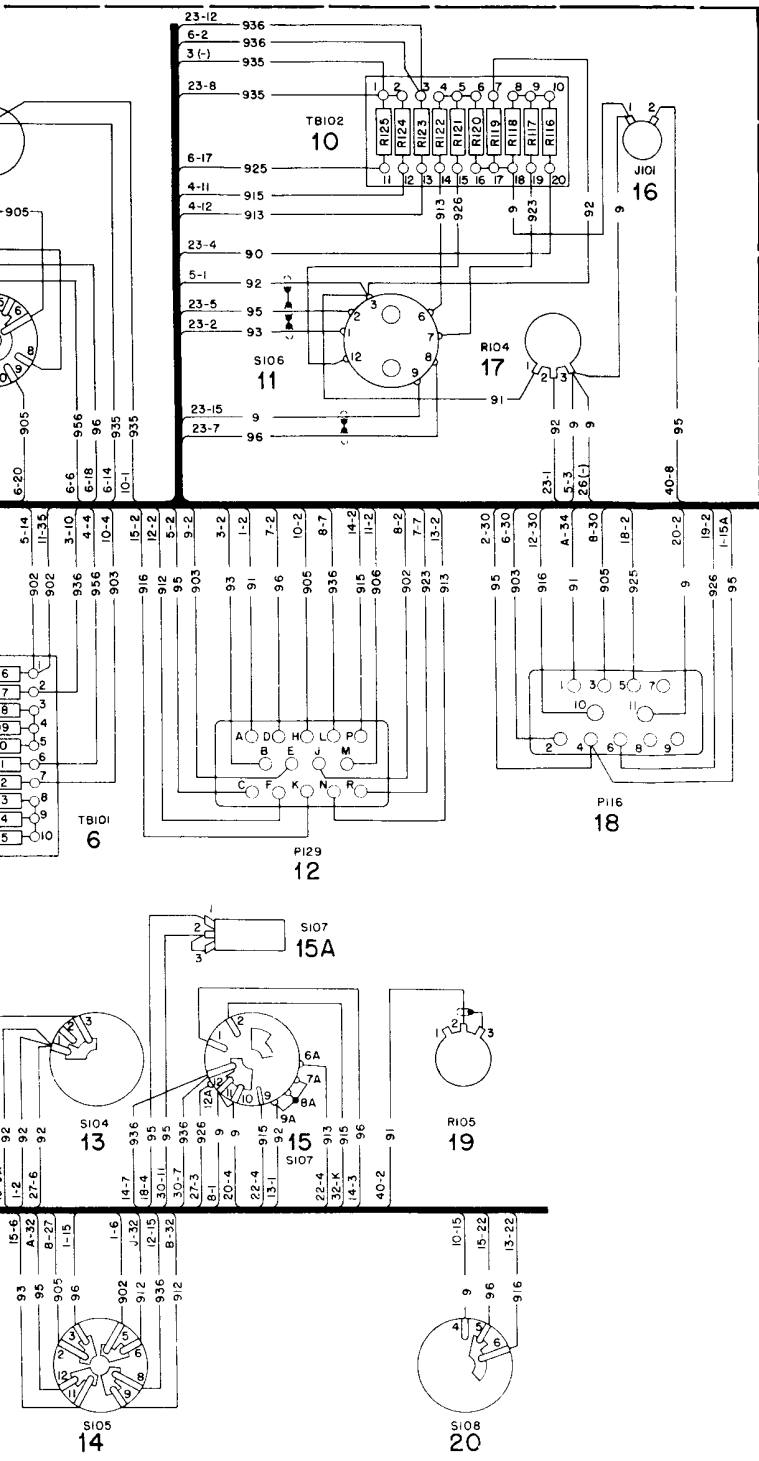

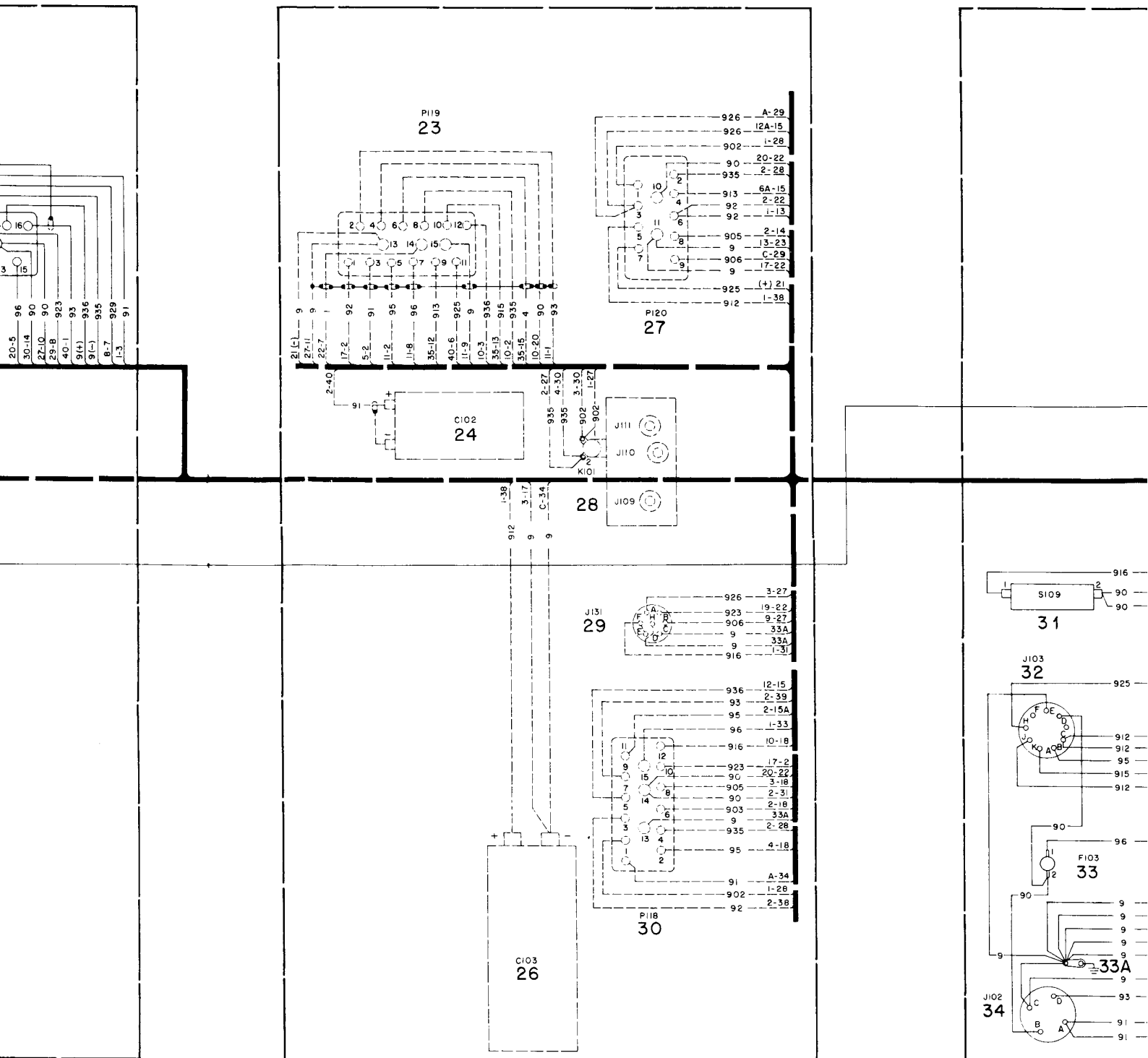
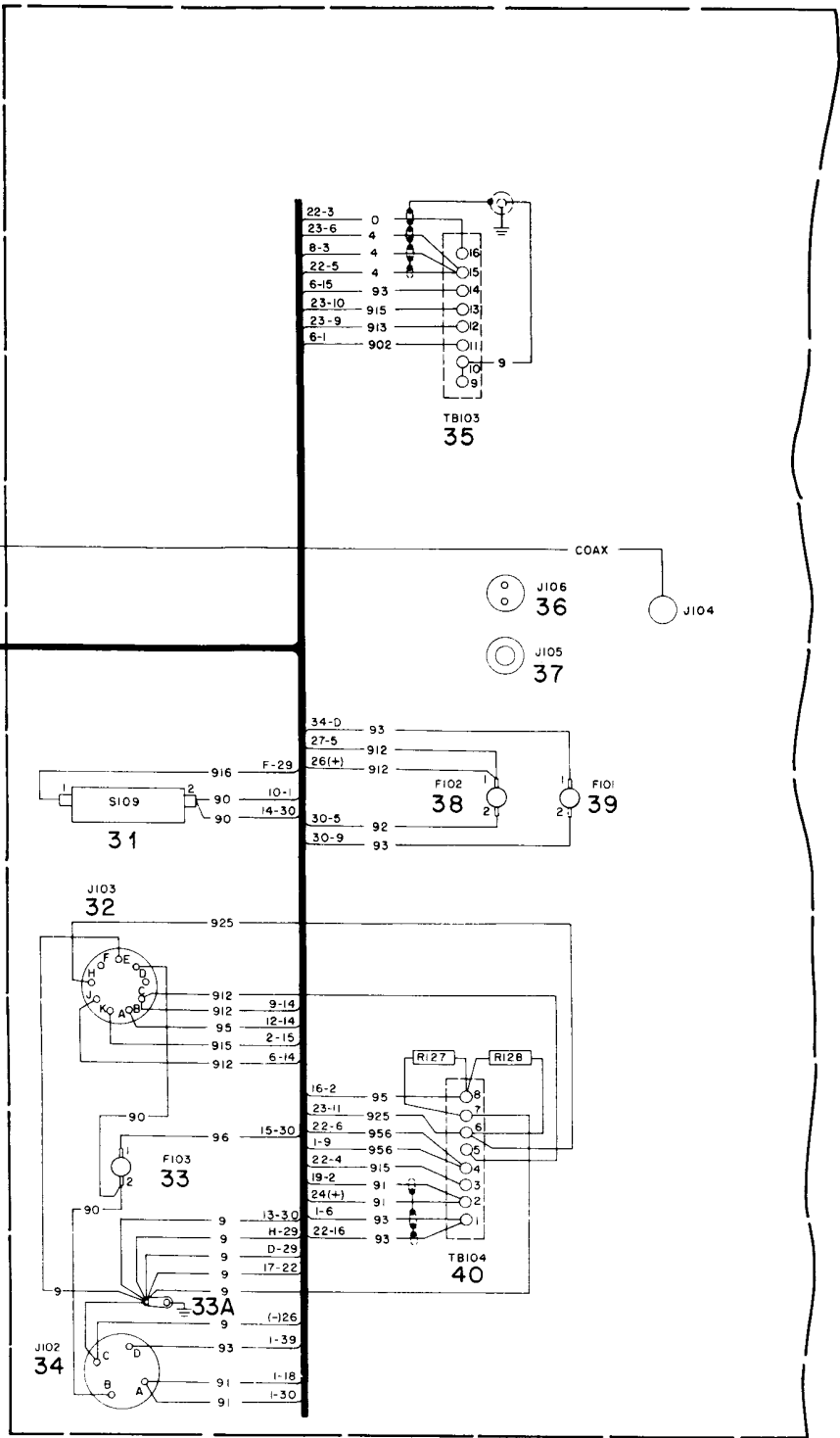

Figure 90. Wiring diagram.



- NOTES:
1. WIRE COLOR CODE APPLIES ONLY TO CABLING
 FIRST NO.-BODY COLOR
 SECOND NO.-WIDE TRACER
 THIRD NO.-NARROW TRACER
 1-BROWN
 2-RED
 3-ORANGE
 4-YELLOW
 5-GREEN
 6-BLUE
 7-VIOLET
 8-WHITE
 9-BLACK
 0-TRANSPARENT
 COAX-COAXIAL
 NO CODE NUMBER-BARE
 2. STATION TO STATION IDENTIFICATION IS SHOWN NEAREST TO CABLING
 3. STATIONS ARE IDENTIFIED BY LARGE NUMBERS
 4. DESTINATION WITHIN STATION IS SHOWN BY NUMBER BETWEEN STATION IDENTIFICATION AND WIRE COLOR CODE
- DESTINATION WITHIN STATION STATION NUMBER
- 923 12-3 WIRING HARNESS
- WIRE COLOR CODE

INDEX

	<i>Paragraph</i>	<i>Page</i>		<i>Paragraph</i>	<i>Page</i>
Additional equipment required.....	12	6	Chart, troubleshooting.....	99	98
Adjustment:			Checking:		
Band-switching motor control switch.....	115	112	B+ circuits for shorts.....	97	87
CARR-METER ADJ potentiometer			Filament circuits for shorts.....	97	87
R537.....	125	122	Mechanical synchronization.....	119	113
Disk clutch assembly.....	117	113	New equipment.....	14	8
FREQ CHANGE slip clutch.....	116	112	Power cable.....	48	30
GAIN ADJ potentiometer R562.....	124	122	Checks:		
Neutralizing capacitor C525.....	126	122	Resistance.....	100	99
Potentiometer R260.....	123	122	Voltage.....	100	99
Test equipment required.....	114	112	Circuit, antenna.....	52	33
Adjustments:			Components, table.....	7	5
Slug rack.....	120	115	Connections.....	16	10
Tools required.....	114	112	Connections, system.....	17	14
Af:			Control:		
Amplifier circuit.....	79	59	Circuits.....	86	72
Amplifier tests.....	104	101	If. bandwidth.....	74	52
Filter.....	79	59	Relay.....	84	69
Age circuit.....	77	56	Controls and instruments.....	19, 20	14
Alinement:			Coupler:		
455-kc if. stages.....	121	117	Input.....	63	46
Rf subchassis.....	122	119	Output.....	65	46
Test equipment required.....	114	112	Crystal filter.....	67	49
Tools required.....	114	112	Crystal oscillator.....	57	40
Amplifier:			Data:		
Af.....	79	59	Packaging.....	6	3
Fifth if.....	72	51	Troubleshooting.....	91	84
First if.....	69	50	Dc resistances:		
If.....	68	49	Coils.....	108	104
Second if.....	70	50	Transformers.....	108	104
Sixth if.....	73	52	Definition of preventive maintenance.....	35	20
Amplifiers, third and fourth if.....	71	50	Demolition, authority.....	136	128
Antenna circuit.....	52	33	Description:		
Antijamming instructions.....	28	18	Cases and cabinets.....	9	5
Application, system.....	4	2	Power Supply PP-621/URR.....	10	5
Arctic climate operation.....	30	18	Receiver.....	8	5
Audio channel:			Desert climate operation.....	32	19
Line.....	81	62	Destruction, methods.....	137	128
Local.....	80	61	Detector circuit.....	75	53
Audio response, overall.....	133	125	Disassembly.....	134	128
Authority for demolition.....	136	128	Disk clutch assembly adjustment.....	117	113
Band-switching motor control switch			Equipment performance check list.....	47	28
adjustment.....	115	112	Equipment required, additional.....	12	6
Beat-frequency oscillator.....	76	55	Fifth if. amplifier.....	72	51
Bench-testing technique.....	93	84	Filament circuits, checking for shorts.....	97	87
Bfo, calibration.....	127	123	Filter:		
Block diagram.....	50	31	Af.....	79	59
B+ circuits, checking for shorts.....	97	87	Crystal.....	67	49
B+ voltage distribution.....	109	105	Low-pass.....	64	46
Buffer.....	59	41	Final testing:		
Calibration of bfo.....	127	123	General.....	129	124
CARR-METER ADJ potentiometer			If. response.....	132	124
R537, adjustment.....	125	122	Overall audio response.....	133	125
Cases and cabinets, description.....	9	5	Preliminary checks.....	131	124
Cathode follower, if.....	78	59	Test equipment required.....	130	124
Characteristics, technical.....	5	2			

	<i>Paragraph</i>	<i>Page</i>		<i>Paragraph</i>	<i>Page</i>
First:			Potentiometer:		
If. amplifier.....	69	50	CARR-METER ADJ, R537, adjust-		
Mixer.....	55	35	ment.....	125	122
Mixer injection circuits.....	60	43	GAIN CONTROL, R562, adjust-		
Rf amplifier.....	53	34	ment.....	124	122
Forms and records.....	2	2	R260, adjustment.....	123	122
FREQ CHANGE slip clutch adjustment.....	116	112	Power cable, checking.....	48	30
Functional analysis of tuning system.....	88	73	Power circuits.....	83	64
FUNCTION switch.....	85	70	Power Supply PP-621/URR, description.....	10	5
GAIN CONTROL potentiometer R562, adjustment.....	124	122	Preliminary checks, final testing.....	131	124
Hum adjustment, regulated voltage.....	118	113	Preventive maintenance:		
If.:			Definition.....	35	20
Amplifier.....	68	49	Forms, use.....	37	21
Bandwidth, control.....	74	52	General techniques.....	36	20
Cathode follower.....	78	59	Performing.....	38	21
Response, final testing.....	132	124	Principles of operation.....	49	31
Stages, 455-kc, alinement.....	121	117	Procedure:		
Subchassis tests.....	105	101	Starting.....	21	16
Injection circuits, first mixer.....	60	43	Stopping.....	27	18
Injection mixers.....	62	44	Troubleshooting.....	90	83
Input coupler.....	63	46	Tuning.....	22	16
Inspection, visual.....	43, 96	25, 85	Purpose of manual.....	3	2
Installation of receiver.....	15	10	Receiver, installation.....	15	10
Limiter circuit.....	75	53	Reception:		
Line audio channel.....	81	62	Tape transmission.....	25	17
Local audio channel:			Tone-modulated radiotelegraph.....	24	17
Tests.....	102	100	Unmodulated radiotelegraph.....	26	17
Theory.....	80	61	Voice.....	23	16
Low-pass filter.....	64	46	Refinishing.....	113	112
Lubrication:			Regulated-voltage hum adjustment.....	118	113
By manufacturer.....	112	112	Relay control.....	84	69
Tuning system.....	111	110	Removals.....	110	105
Measurement of rf sensitivity.....	128	123	Repacking for shipment or limited storage.....	135	128
Methods of destruction.....	137	128	Replacements.....	110	105
Mixer:			Requirements, shelter.....	13b	8
Driver.....	66	48	Resistance:		
First.....	55	35	Checks.....	100	99
Second.....	56	39	Dc, of coils.....	108	104
Mixers, injection.....	62	44	Dc, of transformers.....	108	104
Neutralizing capacitor C525, adjustment.....	126	122	Rf:		
Operation:			Sensitivity, measurement.....	128	123
Arctic climate.....	30	18	Subchassis, alinement.....	122	119
Desert climate.....	32	19	Subchassis tests.....	106	101
Tropical climate.....	31	19	Rf Amplifier:		
Principles.....	49	31	First.....	53	34
Operational test.....	98	93	Second.....	54	35
Oscillator:			Running spares.....	11	6
Beat-frequency.....	76	55	Rustproofing.....	41	22
Crystal.....	57	40	Second:		
Variable-frequency.....	58	41	If. amplifier.....	70	50
Output coupler.....	65	46	Mixer.....	56	39
Packaging data.....	6	3	Service upon receipt of used or recondi-		
Painting.....	41	22	tioned equipment.....	18	14
Parts lubricated by manufacturer.....	112	112	Servicing, general precautions.....	94	85
Performing preventive maintenance.....	38	21	Shelter requirements.....	13b	8
Phase inverter.....	61	43	Signal substitution notes.....	101	99
			Siting.....	13	7
			Sixth if. amplifier.....	73	52
			Slug-rack adjustments.....	120	115

	<i>Paragraph</i>	<i>Page</i>		<i>Paragraph</i>	<i>Page</i>
Spares, running.....	11	6	Tools required:		
Special tools supplied.....	34	20	Adjustment.....	114	112
Squelch circuit.....	82	63	Alinement.....	114	112
Starting procedure.....	21	16	Troubleshooting.....	92	84
Stopping procedure.....	27	18	Tools supplied, special.....	34	20
Subchassis testing.....	44	25	Tropical climate operation.....	31	19
Switch, FUNCTION.....	85	70	Troubleshooting:		
Synchronization, checking mechanical.....	119	113	By using equipment performance		
Synchronization of tuning system.....	120	115	check list.....	46	27
System:			Chart.....	99	98
Application.....	4	2	Data.....	91	84
Connections.....	17	14	Notes.....	95	85
Table of components.....	7	5	Procedure.....	90	83
Tape transmission, reception.....	25	17	Test equipment required.....	92	84
Technical characteristics.....	5	2	Tools required.....	92	84
Technique, bench-testing.....	93	84	Tube-testing techniques.....	45	26
Techniques, tube-testing.....	45	26	Tuning procedure.....	22	16
Test equipment required:			Tuning system:		
Alinement.....	114	112	Detailed analysis.....	89	76
Final testing.....	130	124	Functional analysis.....	88	73
Troubleshooting.....	92	84	General principles of operation.....	87	73
Testing subchassis.....	44	25	Lubrication.....	111	110
Test, operational.....	98	93	Synchronization.....	120	115
Tests:			Unmodulated radiotelegraph reception.....	26	17
Af amplifier.....	104	101	Unpacking new equipment.....	14	8
If. subchassis.....	105	101	Use of preventive maintenance forms.....	37	21
Local audio channel.....	102	100	Variable-frequency oscillator.....	58	41
Rf subchassis.....	106	101	Vfo subchassis tests.....	107	104
Vfo subchassis.....	107	104	Visual inspection.....	43, 96	25, 85
Third and fourth if. amplifiers.....	71	50	Voice reception.....	23	16
Tone-modulated radiotelegraph reception.....	24	17	Voltage checks.....	100	99
Tools and materials.....	33	27	Weatherproofing.....	40	22

[AG 413.44 (26 Apr 55)]

BY ORDER OF THE SECRETARIES OF THE ARMY AND THE AIR FORCE:

MAXWELL D. TAYLOR,
*General, United States Army,
Chief of Staff.*

OFFICIAL:

JOHN A. KLEIN,
*Major General, United States Army,
The Adjutant General.*

OFFICIAL:

E. E. TORO,
*Colonel, United States Air Force,
Air Adjutant General.*

N. F. TWINING,
Chief of Staff, United States Air Force.

DISTRIBUTION:

Active Army:

CNGB (1)
Tec Svc, DA (1)
Tec Svc Bd (1)
CONARC (5)
CONARC Bd (Incl ea Test Sec) (1)
Army AA Comd (2)
OS Maj Comd (5)
OS Base Comd (5)
Log Comd (5)
MDW (1)
Armies (5)
Corps (2)
Tpg Div (2)
Ft & Cp (2)

Gen & Br Svc Sch (5)
SigC Sch (25)
Gen Depots (2)
SigC Sec, Gen Depots (10)
SigC Depots (20)
POE (2)
OS Sup Agencies (2)
SigC Fld Maint Shops (3)
SigC Lab (5)
Mil Dist (1)
Ariz Mil Dist (2)
Units organized under following
TOE's:
11-7, Sig Co Inf Div (2)

11-16A, Hq & Hq Co, Sig Bn,
Corps or Abn Corps (2)
11-57, Armd Sig Co (2)
11-127, Sig Rep Co (2)
11-128A, Sig Depot Co (2)
11-500A (AA-AE), Sig Svc Org
(2)
11-557A, Abn Sig Co (2)
11-587A, Sig Base Maint Co (2)
11-592A, Hq & Hq Co, Sig Base
Depot (2)
11-597A, Sig Base Depot Co (2)

NG: Same as Active Army except allowance is one copy to each unit.

USAR: None.

For explanation of abbreviations used, see SR 320-50-1.

